



This is a digital copy of a book that was preserved for generations on library shelves before it was carefully scanned by Google as part of a project to make the world's books discoverable online.

It has survived long enough for the copyright to expire and the book to enter the public domain. A public domain book is one that was never subject to copyright or whose legal copyright term has expired. Whether a book is in the public domain may vary country to country. Public domain books are our gateways to the past, representing a wealth of history, culture and knowledge that's often difficult to discover.

Marks, notations and other marginalia present in the original volume will appear in this file - a reminder of this book's long journey from the publisher to a library and finally to you.

### **Usage guidelines**

Google is proud to partner with libraries to digitize public domain materials and make them widely accessible. Public domain books belong to the public and we are merely their custodians. Nevertheless, this work is expensive, so in order to keep providing this resource, we have taken steps to prevent abuse by commercial parties, including placing technical restrictions on automated querying.

We also ask that you:

- + *Make non-commercial use of the files* We designed Google Book Search for use by individuals, and we request that you use these files for personal, non-commercial purposes.
- + *Refrain from automated querying* Do not send automated queries of any sort to Google's system: If you are conducting research on machine translation, optical character recognition or other areas where access to a large amount of text is helpful, please contact us. We encourage the use of public domain materials for these purposes and may be able to help.
- + *Maintain attribution* The Google "watermark" you see on each file is essential for informing people about this project and helping them find additional materials through Google Book Search. Please do not remove it.
- + *Keep it legal* Whatever your use, remember that you are responsible for ensuring that what you are doing is legal. Do not assume that just because we believe a book is in the public domain for users in the United States, that the work is also in the public domain for users in other countries. Whether a book is still in copyright varies from country to country, and we can't offer guidance on whether any specific use of any specific book is allowed. Please do not assume that a book's appearance in Google Book Search means it can be used in any manner anywhere in the world. Copyright infringement liability can be quite severe.

### **About Google Book Search**

Google's mission is to organize the world's information and to make it universally accessible and useful. Google Book Search helps readers discover the world's books while helping authors and publishers reach new audiences. You can search through the full text of this book on the web at <http://books.google.com/>

COURTNEY LIBRARY



HC 2PBJ 0

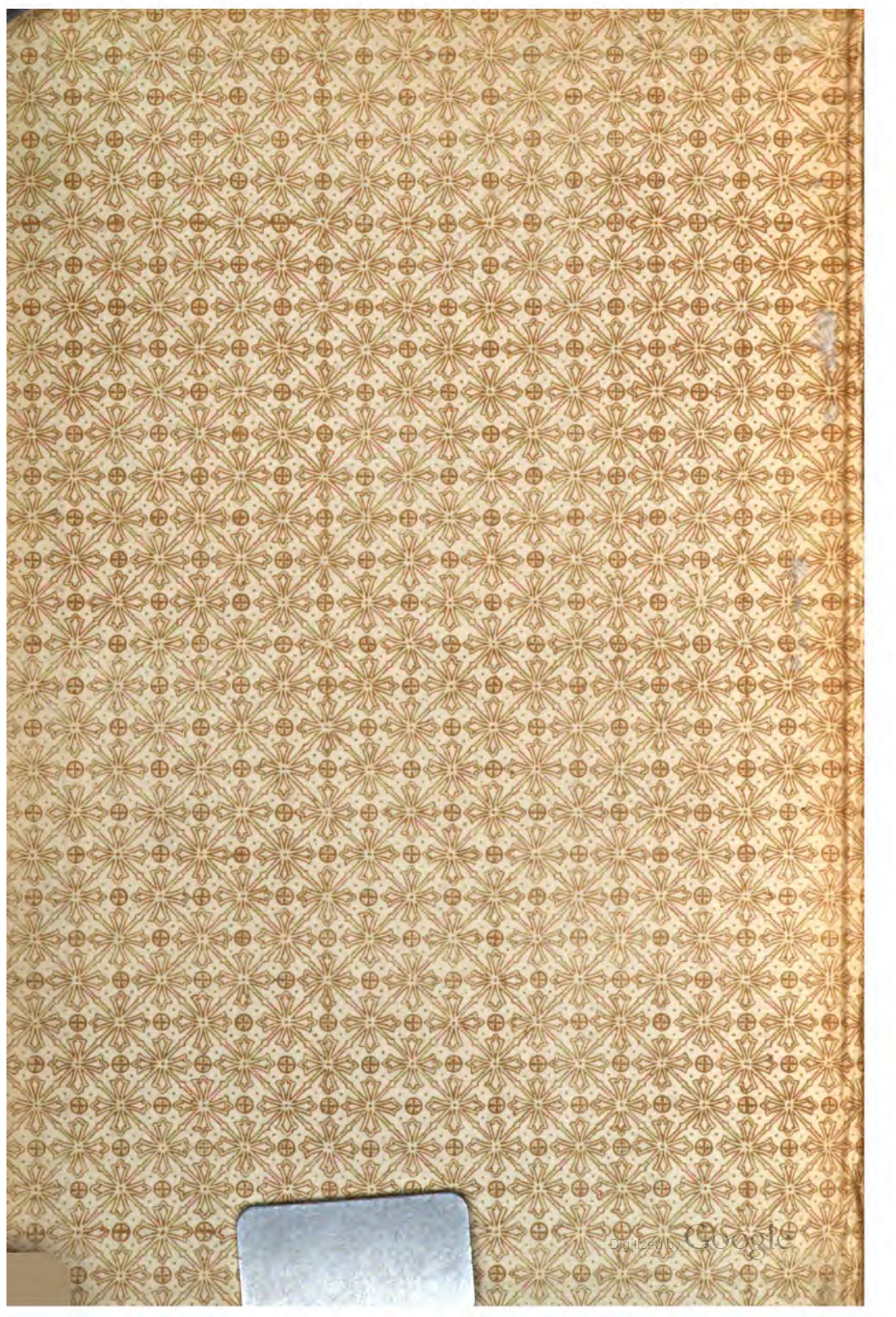

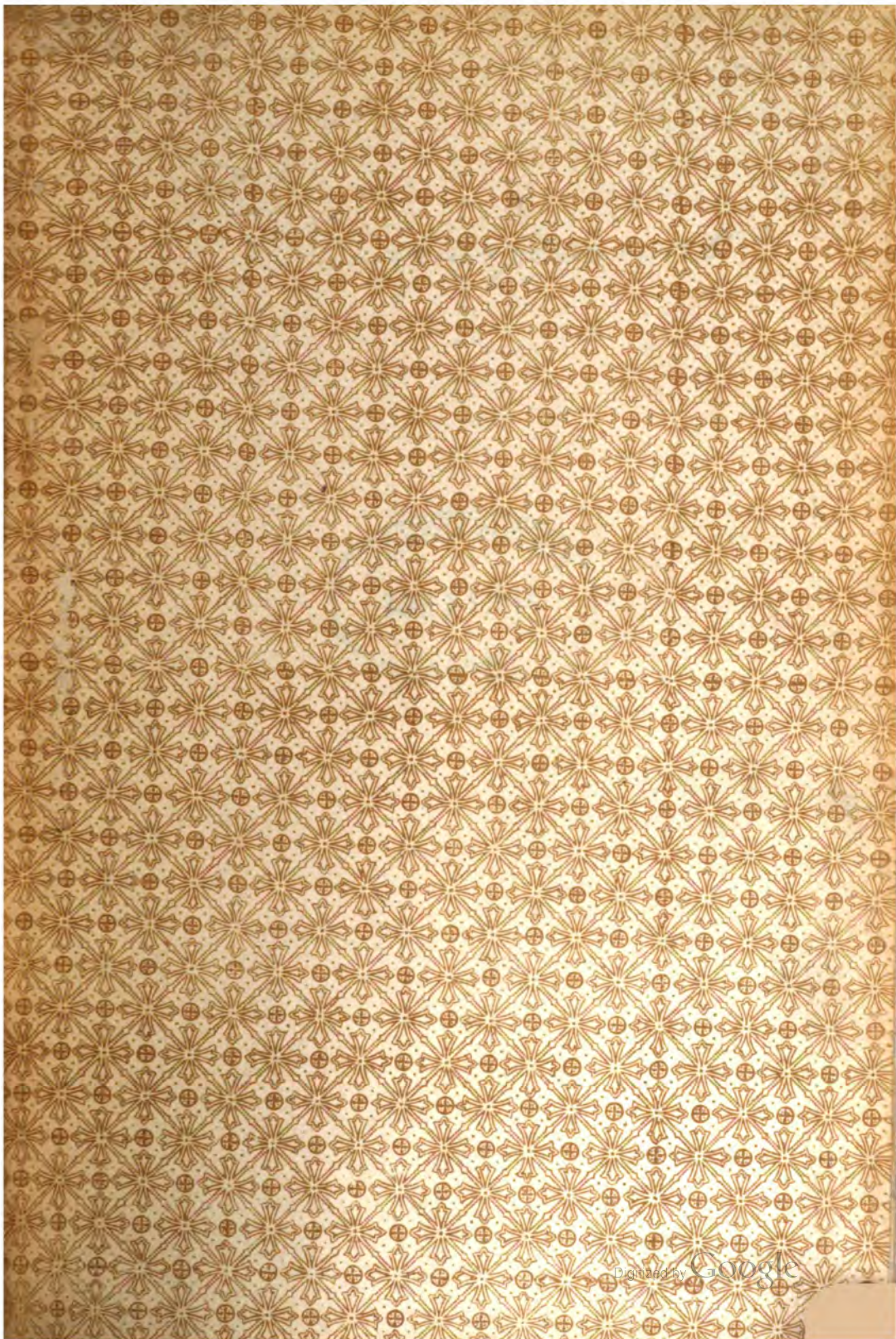

*Frances Jones.*

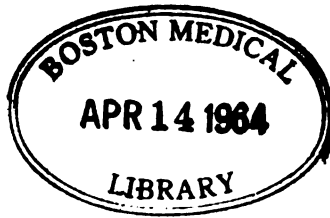

100











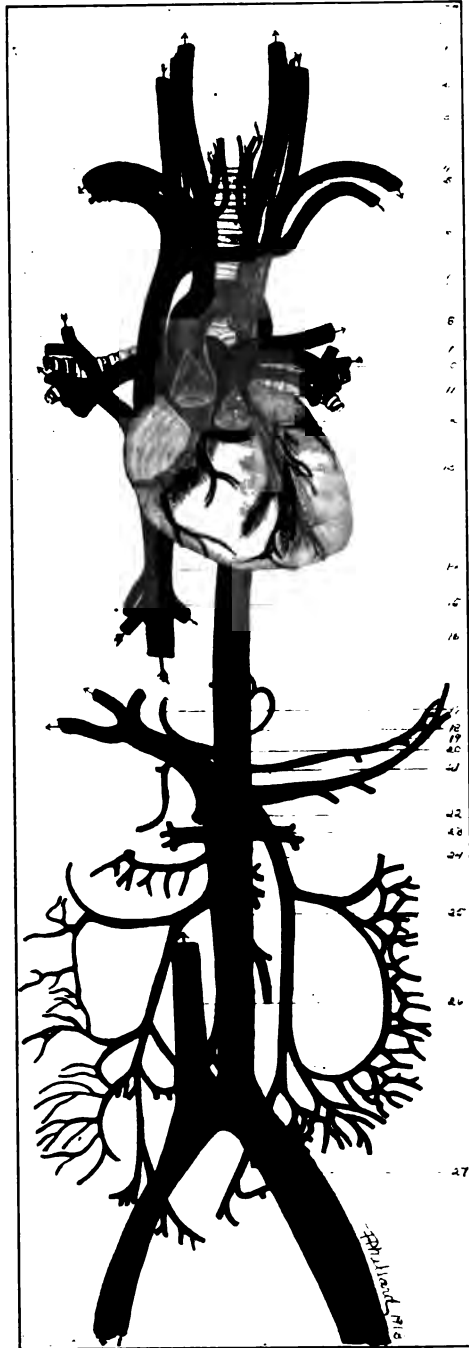

PLATE I.—THE CIRCULATION OF THE BLOOD. 1. Left common carotid; 2. left pneumo-gastric nerve; 3. internal jugular vein; 4. left subclavian artery; 5. trachea; 6. right recurrent laryngeal nerve; 7. innominate artery; 8. left recurrent laryngeal nerve; 9. pulmonary vein; 10. pulmonary artery; 11. mouth of left coronary artery; 12. semilunar valve; 13. coronary vessels; 14. inferior vena cava; 15. hepatic veins; 16. aorta; 17. hepatic artery; 18. gastric artery; 19. coeliac plexus; 20. portal vein; 21. splanchnic artery; 22. superior mesenteric artery; 23. renal artery; 24. inferior mesenteric vein; 25. superior mesenteric vein; 26. inferior vena cava; 27. common iliac artery.



# PHYSIOLOGY:

## GENERAL and OSTEOPATHIC

---

A REFERENCE AND TEXT BOOK  
For Osteopathic Students and Physicians

BY

J. DEASON, Sc. B., M. S., Ph. G., D. O.

*DIRECTOR OF THE A. T. STILL RESEARCH INSTITUTE  
AND FORMERLY PROFESSOR OF PHYSIOLOGY IN  
THE AMERICAN SCHOOL OF OSTEOPATHY*

Member of the American Osteopathic Association  
Member of the Missouri Osteopathic Association

---

PRESS OF  
THE JOURNAL PRINTING COMPANY  
KIRKSVILLE, MO.

**COPYRIGHT, 1913**

**BY**

**J. DEASON**

## INTRODUCTION.

The study of physiology is far from being a complete science. Since this subject deals with the structure and functions of living organisms it becomes much more difficult to measure and express our results in numbers than in such sciences as physics and chemistry, and until we are able to do this physiology will continue to be the results of theoretical speculation rather than a definite science. This, however, is wholly different from saying that there is nothing definitely known relative to the functions of living structures, for on the other hand we are greatly indebted to the many research workers and clinical investigators who have so earnestly and conscientiously solved many problems along these lines. The ultimate purpose of the development of physiology into a definite science should be that of gaining such information of living organisms that physicians may be able to treat human ailments intelligently. Other purposes, such as the addition of general scientific information to other sciences, is of course a justifiable one, but it seems that this should be a secondary consideration. Research workers in physiology must, however, proceed along strictly scientific lines and not allow themselves to be biased, but must follow the results of their findings regardless as to where they may lead.

Work in physiological research has for the most part been done by instructors and assistants in medical colleges, and they have devoted much of their time to research work pertaining especially to drug therapy. During more recent years, since the endowed universities have taken up original scientific research in physiology, the work on this subject as well as in other branches has been more general.

In medical as well as other sciences it is generally true that the science follows the art of practice. In medical practice this

is especially true except that the results of scientific research—the science—has failed to confirm the methods of practice.

Osteopathy is a comparatively new system of practice, having existed for only about twenty years, and yet much valuable research work has already been done along new and wholly different lines. We believe that no other school of practice has done as much original scientific investigation pertaining to the theories of its methods of treatment according to the length of time it has existed, and I am sure that no other school has been more successful in confirming its theories by the results of its research. That the osteopathic theory is fundamentally scientific no one who has kept up with the results of its growth, research, and practice can doubt. The original plan and the fundamental principles of osteopathy were given by Dr. Andrew Taylor Still, a man particularly adapted to research and original investigation and who now, in his eighty-fifth year, is still an active student. Dr. Still has been a frequent and most welcome visitor in my classes at the American School of Osteopathy, and I am very greatly indebted to him for much valuable information received along osteopathic lines.

Because the science of physiology is so broad, and because it involves so many different phases of the organic and inorganic sciences, no one individual can ever hope to obtain a thorough knowledge of the entire subject. I, therefore, frankly admit my inability to write a book on the subject without the aid of those whose original investigation and experience have been much more far reaching than my own. In the preparation of this book I admit frequent reference to the best modern authorities in general physiology, such as Starling, Howell, Stewart, Sherrington, Luciani, Landois, Schafer, and many others. For principles of physiology pertaining especially to osteopathy I have consulted the writings of Burns, McConnell, Whiting, R. K. Smith, Hulett, Hazard, Farmer, Tasker, and others. That these authorities might receive due credit I have frequently quoted from their most recent publications.

In order that this book might be thoroughly reliable, so far as the part on general physiology is concerned, I have referred to

and quoted from only the best authorities on this subject, using only most recent editions of their books. In order that the part pertaining to the osteopathic principles of physiology might be reliable I have asked assistance from our foremost research workers along these lines.

Osteopathy is a system of healing which considers the fundamental relations of structure to function and the co-ordinative functions of all body structures acting together as a unit. The workers in general physiology, it seems to me, do not give these problems due consideration and the osteopathic student cannot, therefore, get sufficient understanding of the subject from a study of the general text-books. This book has been prepared for the purpose of meeting this demand. It is offered only as a contribution to the general subject of physiology, as a special contribution to osteopathic literature, and is not intended to revise the whole trend of physiological or osteopathic thought. No attempt has been made to conform to the theoretical conventionalities so common to the general texts on physiology, but on the other hand the authors have endeavored to make the book thoroughly osteopathic because it is written for the use of osteopathic students and physicians. The book has been arranged in two parts, the first giving the principles of general physiology, omitting as much as possible of the seemingly unnecessary theory, the second giving the results of original osteopathic research. I am very deeply indebted to Drs. McConnell, Burns, and Whiting for the excellent summaries of their research work, and to Dr. Millard for the drawings which he has prepared and from which all the colored plates have been made. I feel highly sensible of my deep obligation to these doctors, because without their assistance the book could not have been prepared, and I trust that the plan of co-operation will be continued and that it may result in the development of much valuable osteopathic literature in the future. I am also indebted to the editors of the Journal of the American Osteopathic Association, the Herald of Osteopathy, and the Journal of Osteopathy for allowing me the use of some of their colored plates, and to the C. H. Stoelting Company for the use of a few of their cuts.



## STRUCTURE AND FUNCTION.

The existence of all living organisms is dependent upon the intimate relations which exist between the various component parts or structures of the organism and the work or functions which these structures have to perform.

In primary physiology we are taught that "man is a machine" and that his various working parts have their specific kind of work or functions to perform and that, failing in this, a perversion of function results and this failure of the normal function means disease. The study of the fundamental relations of structure to function should then be the aim of every student of physiology.

By the term structure is meant the body framework, its organs and other constituent parts. The term body tissue is applied to a structural part of the body consisting of an aggregation of similar cells having a similar function or similar functions, e. g., bone, which forms the frame work; cartilage, which pads the joints and allows movement without wear; muscle, the contraction of which causes movement of the body levers, the bones; and nerve tissue, which is the body messenger and serves to connect the various structures in their functional relations and to regulate these functions. It will, of course, be left for the histologist to explain the minute or microscopic structure of the various tissues.

**Relations of Structure to Function.**—Function may be defined as the specific work of an organ or tissue of the body. An organ is a specialized structure whose function is some special kind of work. In order that any tissue or organ may perform its normal function it must itself be normal in its development, its growth, its cellular composition, and in its structural relations with other organs. The last of these requirements is probably most

essential because, if the structural relations are right, normal development, growth, etc., will follow.

If, on the other hand, any abnormal structural relations exist these may affect the blood or nerve supply or in some other way interfere with its development, growth, or the functional activities of its component cells, thus affecting the functions of the organ. It is well known that the functions of any individual structure depend not only on its own normal structural relations, but to some extent upon the functional activities of other structures. If the heart, for example, fails to pump the necessary amount of blood to any certain organ or if the nerve supply for any reason is insufficient, thus rendering the regulation of its functional activities abnormal, that structure fails to perform its normal kind or amount of work. Since the various organs of the body bear certain functional relationships to each other, any perversion of the functions of one structure may materially interfere with the functions of other structures, and thus we have an example of the unity of body structures and their functions.

This dependence of function upon structure may again be compared to the working of a machine. If at any time a certain mechanism fails in its proper adjustment the work of that part is impaired or lost, and in most cases the entire machine is valueless until this one part is repaired.

**Structure Depends upon Function.**—In the above paragraphs it has been shown that normal function depends upon normal structure and now we must state the converse, viz., that normal structure is dependent upon normal function, which is also true. To illustrate we may use the example of the blacksmith's arm to show how cultivation of the function tends to develop and normalize structure, or on the other hand how, when one fails to take the necessary amount of exercise, his muscles atrophy and become weak. In future chapters the more complicated and intricate relations will be discussed which show these same principles.

Certain laws of physics apply also to the body as well as to other mechanisms. The laws of conservation and transformation

of energy, for example, hold good for the animal machine. The source of energy is the food and air used as fuel. It may be transformed, transferred, or lost, but cannot be created within the body. The efficiency of the body machine is much greater than that of other machines, but here again the efficiency depends upon the degree of perfection of its structural relations.

**Body Repair.**—The body machine has one marked advantage over other machines and that is that it maintains its own repair shop. Certain cellular elements of the body, the red blood corpuscles, serve to replenish the various tissues with oxygen and the blood in this and other ways repairs tissue as it wears and also furnishes material for energy to its muscles and other working organs. The blood also carries other cells, the white blood corpuscles, which may be called scavenger cells, whose function is to carry away waste and protect against the invasion of bacteria, etc.

From the above paragraphs it may be seen that the body is an automatic machine in that it repairs its own wear and regulates its own work. Normal structure and structural relations mean normal functions and this stated in the converse, viz., that normal function cannot result from abnormal relations, is the osteopathic theory of disease. Just so long as normal structural and functional relations of the body machine are normal the individual will show evidence of that phenomenon which we call life.

**Physiology** may be defined as that branch of science which treats of the various changes and processes occurring in the animal organism during life.

**Physiological changes** are those changes, whether physical or chemical in nature, which occur in the normal living body. The term metabolism is generally attached to these changes and usually applies to physiological chemical changes which occur in the various tissues. Metabolism may be either constructive, a building or forming process, anabolism, or it may be destructive, a breaking-down process, catabolism. Changes anabolic in nature occur in tissue building, cell formation, etc., in which protein material from the foodstuffs, for example, is built into living tissue substance; and changes catabolic in nature occur in the destructive

oxidation processes of certain foods, carbohydrates, fats, etc., the result of which is the liberation of heat and other forms of energy which yield power to do work.

These changes occur in all living organisms, animals and plants, and are necessary for the life processes of the organisms. In the lower forms of life, such as the amœba, all necessary life processes can be effected in the one simple cell of which the animal consists.

There are certain essential functions necessary to the life of every living animal, regardless of its scale of development. These are known as the essential physiological functions of protoplasm. They are metabolism, which has been defined; movement, by virtue of which animals are enabled to move or change their environmental conditions, which in case of the lowest forms consists of an amœboid movement, by means of which the animal may adjust its body to new food supplies, etc.; the third function is growth, a process of continued constructive metabolism; fourth, reproduction, the process by means of which the animal reproduces its kind; the fifth, irritability, or the quality of responding to a stimulus. A sixth is sometimes given, which is a specific one and refers to some function of a specialized or highly differentiated structure.

In the higher forms of life these various functions are performed by organs highly differentiated and adapted for the performance of some one or more special functions. Movement in the higher forms, for example, is effected by the musculature, irritability by the system of nerves, etc. This differentiation of structures for the purpose of performing these special and separate functions enables the higher animals to do work and perform the various life processes much more perfectly, and constitutes a plan of physiological division of labor.

**The Cell Theory.**—Early in the eighteenth century the theory was advanced by Schleiden and Schwann, supported by other observers, that the cell constituted the histological basis of all animal structure. Since that time various workers in the biological sciences have developed this idea into a very explana-

tory theory of all life processes, the main principles of which are discussed in the following paragraphs:

1. The cell constitutes the anatomical and physiological unit of the organism, and the life processes of the individual organism are determined by the nature of the various cells which compose it.

2. Anatomically the various cells have undergone various processes of differentiating changes during the phylogenetic evolution of the organism, and now in the higher forms of life these specially differentiated structures which have resulted have the power of performing specialized functions according to the nature of the structure.

3. The cell is to the organ as the organ is to the body; that is, the functional activities of the organ depend upon the nature of the cells which compose it, just the same as the functional activities of the body as a whole depend upon the nature of its various organs.

4. The unity of functional relationships of the body as a whole depends upon the completeness of the functional activities of its various organs, and in turn the unity of function of the organ depends upon the functional activities of its various cells.

5. Every cell in the organ bears a certain functional relationship to every other cell of that structure, every organ of the body bears certain functional relations to every other organ, and the maximum of perfection of the various functions of all cells and organs renders to the body as a whole the sum total of perfect functional activity or health.

6. By the physiological division of labor, then, all of the various structures have special functions to perform, and any one of these failing in its function may cause an unequal balance or perversion of function and the result is disease.

Since normal function can be effected only by normal structure and since also normal structural relations must exist in all tissues, because of the inter-relations existing between the various structures, any perversion of structure may and usually

will result in abnormal function, and this is the osteopathic theory of health and disease.

General physiology is that branch of science which treats of the various functions of the living animal. Special physiology is a branch of general physiology which teaches the special functions of some specialized structure or structures. Human physiology refers to those physiological changes occurring in the human body. Cellular physiology refers to those physiological changes occurring in the cell. Osteopathic physiology is that branch of general physiology which considers especially the relations of structure and function and the unity of these combined functions.



# SECTION I

---

## THE BODY FLUIDS





# **PART I**

## **PRINCIPLES OF GENERAL AND OSTEO- PATHIC PHYSIOLOGY.**

---

### **CHAPTER I.**

#### **BODY FLUIDS.**

In the lower forms of life the food of the single-celled animals is contained in the fluids in which they live, and likewise the body excreta of these simple forms is thrown off into and carried away by these fluids. The animal only needs to move a short distance to bring itself into relation with new food supplies in its surrounding medium. As the animal body becomes more complex in the higher forms of life this method of supplying its cells with food and relieving them of their wastes becomes impossible, and there originates a demand for a new structural system for supplying this function, and the demand is supplied by the blood-vascular system. This system, which consists of closed tubes in which the body fluids circulate, serves the functions of carrying food supplies to the various tissues, removing the waste products of cell metabolism, and other functions to be discussed later. These fluids consist of blood and lymph and the serums from these fluids, which are found in the various extravascular spaces in the body. In case of the blood, it is first pumped from the heart through the arteries and into the thin-walled capillaries, where it comes in almost direct contact with the cells of the various tissues. Here certain contents of the blood are given up to these tissues and certain wastes from

the tissue cells are emptied back into the blood stream. In some instances, as in the case of those vessels which supply the intestinal tract, food materials are taken up by the blood and carried to other tissues where they are needed or carried to some storehouse, as in case of the liver, and kept for future use. After the blood leaves the capillaries it passes into the veins and is carried back to the heart to begin its circulation anew.

Not all of the tissue wastes are emptied back into the blood stream. Some go by another route, the lymph channels. The lymph vessels are small, thin-walled tubes containing valves to prevent back-flow, and serving the function of carrying the extravascular fluids back to the veins.

### **BLOOD.**

**General Properties.**—Blood has an average specific gravity of 1.055, varying under certain conditions within very narrow limits. The specific gravity of blood is best determined by comparing with liquids of known density. A mixture of chloroform and benzol may be so prepared that the solution has a specific gravity of 1.055. A drop of fresh blood is allowed to fall into this solution. If it sinks it is known to be heavier, and if it floats on the surface it is known to be lighter than the test fluid. There are certain instruments sometimes used for this purpose, but they are not of any great value in practical determinations. The specific gravity of the blood varies slightly with age, sex, time of day (being slightly higher at night), etc., but this is of no practical consideration. Blood is normally neutral in reaction when tested with phenolphthalein as an indicator, but may be slightly alkaline when tested with litmus.

The color of blood varies from that of scarlet in the arteries to purplish in the veins. The presence of oxyhemoglobin in arterial blood gives the scarlet color, and the intensity of the color varies with the amount of oxyhemoglobin. The oxygen of the hemoglobin is given up to the tissues as the blood passes through the capillaries; thus the change of color in the veins.

**CONSTITUENTS OF BLOOD.**

Plasma is the liquid portion of the blood in which the corpuscles float. Its specific gravity varies from 1.026 to 1.030. Serum is the liquid portion of the blood after coagulation, and represents the plasma minus fibrinogen. The clot consists of corpuscles and fibrin. Stewart compares these as follows:

Plasma + fibrin (ogen) = serum.

Corpuscles + fibrin = clot

Plasma + corpuscles = serum + clot = blood.

**Red Blood Corpuscles.**—The red blood corpuscles or erythrocytes are discal, biconcave bodies, 7.5 micra in diameter, 2.5 micra in thickness at the periphery, and from 1 to 2 micra thick at their mid-portion. The normal number of erythrocytes for the adult male is 5,000,000 per cubic millimeter and for females 4,500,000 per cubic millimeter.

**Physiological Variation in Number.**—The number of red corpuscles varies with certain conditions, as follows: 1. The number varies inversely with age, i. e., the greatest number being found in the foetus and gradually decreasing during the life of the individual; 2. the number is decreased in females, being about 4,500,000 per cubic millimeter; 3. the number is decreased after meals; 4. the number is slightly increased during menstruation, and 5. is diminished during pregnancy; 6. the number is increased in those living in high altitudes, and in those going from low to high altitudes the number may be increased to as many as 7,000,000 or 8,000,000 and the change occurs quickly, being noted within a few (twelve to forty-eight) hours. This change seems to occur in answer to a demand of function, there being a call on the system for a greater oxygen-carrying power, due to the lessened amount of oxygen in the air.

The function of erythrocytes is to carry oxygen from the lungs where it is taken from the inspired air, and to carry it to the cells of the various tissues. The oxygen is carried by means of the hemoglobin contained in the corpuscles. Erythrocytes consist of stroma, which is the structural part; certain salts, such as

lecithin and cholesterin; water, and hemoglobin, the latter being its chief functional constituent. The hemoglobin constitutes about 32% by weight of the erythrocyte, and 90% of the total solids. It is not known how the hemoglobin is held in the corpuscle, but it is believed to be held in some way by the stroma. Whether the lecithin or cholesterin take any part in the specific functions of the corpuscles is not known. According to Starling the red blood corpuscles constitute about 50% of the total mass of the blood. These small bodies are flexible and elastic, and readily return to their original form when distorted by pressure. The size and shape of the corpuscles vary with different animals. In nearly all mammals they have the shape described above. In vertebrates below the mammals and other animals still lower in the scale of development the red corpuscles are nucleated and biconvex, but normally they have no nuclei in the human. In camels they resemble the human type, but are oval instead of circular. During the first few weeks of foetal life; after the loss of a quantity of blood by hemorrhage; in certain blood diseases, and before they are passed into the blood stream from their source of formation, the red blood corpuscles of the human may be found to contain nuclei. Nucleated red blood corpuscles or normoblasts are never found in normal blood of the normal human individual after birth. The total surface area of all of the blood corpuscles of the blood is about "1500 times the surface of the body itself" (Starling). This fact shows the great oxygen-carrying capacity of these corpuscles.

Red blood corpuscles are continually being formed from erythroblasts, the forerunners of the red blood corpuscles contained in the red bone marrow of the epiphyses, and after the development is complete and they have lost their nuclei they are taken up by the blood stream and carried through the circulatory system. In the bone marrow, where the vessels are dilated and the capillaries are very thin-walled, these small bodies may easily enter the vessels. The red bone marrow is the chief and possibly the only hematopoietic (blood-forming) structure in the adult, but the liver and spleen are generally considered as embryonic hema-

topoietic structures, having to do with the formation of the red blood cells during early embryonic and foetal life.

Erythrocytes are constantly undergoing degeneration. It is not known how long they exist in the blood stream as functional structures. The products of disintegration as they degenerate are probably taken up and carried away by the leucocytes. In the spleen and in the hemolymph glands certain large phagocytic cells may be found which often contain ingested parts of disintegrated erythrocytes, and it is generally supposed that these structures have something to do with the fate of the useless red blood cells. The hemoglobin of the red corpuscles is taken up by the liver cells and excreted in the bile.

### HEMOGLOBIN.

Chemically, hemoglobin is a complex protein consisting of carbon, hydrogen, nitrogen, oxygen, sulphur, and iron. The molecular formula has not been positively determined, but it is known that the molecule is very large. Hemoglobin may be readily broken down by the action of heat or by the addition of alkalis or acids, forming two compounds, hematin and globin, and other undetermined substances. The globin constitutes the greater part of the molecule (about 90%) and the hematin constitutes a much smaller part (about 4%) of the molecule. If hemoglobin be decomposed in the absence of oxygen the products are hemochromogen and globin instead of hematin and globin.

Hemoglobin forms an important constituent of the blood of all vertebrate and many invertebrate animals, and its function, as already stated, is that of carrying oxygen. Hemoglobin constitutes about 14% by weight of human blood, i. e., 100 grams of blood would contain 14 grams of hemoglobin. "It is estimated that in the blood of a man weighing 68 kilograms there are contained about 500 to 700 grams of hemoglobin, which is distributed among some 25,000,000,000,000 of corpuscles, giving a total superficial area of about 3200 square meters." (Howell.) From this statement and the discussion above relative to the surface area

of the red corpuscles, it may be seen that a very great area is exposed for the purpose of absorption of oxygen in the lung area and the distribution of oxygen to the tissues.

**Hemoglobin Compounds.**—In the lungs hemoglobin readily unites with oxygen from the inspired air, forming a definite chemical compound, oxyhemoglobin. This gives to blood its characteristic scarlet color. It may be shown experimentally by passing air through freshly drawn venous blood that the color may be made to change to scarlet. It is probable that each molecule of hemoglobin unites with one molecule of oxygen in the formation of oxyhemoglobin. The compound thus formed is not a stable one, but liberates the oxygen readily when in relation with tissues whose cells are in need of oxygen. The advantage of such a weak combination may readily be seen, for if the oxygen united in such a way as to form a stable compound, the oxygen could not easily be separated for the supply of tissue cells.

With many other substances such as carbon monoxide, oxides of nitrogen, etc., hemoglobin forms stable compounds, one molecule of the hemoglobin uniting with one molecule of carbon monoxide. Because of the formation of this stable compound and because the hemoglobin is thus rendered unable to unite with oxygen for the purpose of carrying it to tissue cells, the carbon monoxide causes asphyxia or suffocation for the lack of oxygen. Asphyxia from gas is due to this cause, the carbon monoxide of the gas rendering the corpuscles unable to carry oxygen.

Iron forms an important constituent of hemoglobin, and while it is present in small quantities (about .33%) this amount is so constant that an estimation of hemoglobin may be made by determining the amount of iron. The function of iron is that of assisting the hemoglobin in combining with oxygen.

Hemoglobin of the blood may be estimated quantitatively by certain instruments (hemoglobinometers), but these are not so practical as the colorimetric method, which is done by comparing the color of a blood stain made by placing a drop of freshly drawn blood upon a piece of absorbent paper and comparing this with certain standard colors, the percentages of which are marked

on the scale. The Tallqvist scale is the one most commonly used in clinical work.

**Hemoglobin Crystals.**—By adding a few drops of ether to freshly drawn blood contained in a test tube and shaking the mixture until the blood is hemolized and then quickly cooling with ice, the crystals may be deposited. The crystals may be observed by placing some of the sediment on a slide and examining with the microscope. Oxyhemoglobin and hemoglobin both readily crystallize and the forms of the crystals are characteristic of the species, i. e., the form, shape, and size of the crystals vary in different animals. The difference in the form of the crystals is probably due to some difference in the molecular arrangement of the hemoglobin of the particular species from which it comes.

**Hemolysis.**—The process of separation of the hemoglobin from the red corpuscle so that it may pass into solution in the plasma is known as hemolysis. Blood when so changed is known as hemolyzed or laky blood, and substances which have the power of producing a hemolysis are known as hemolytic agents, e. g., bile salts, chloroform, alcohol, ether, various alkaline salts, etc. A great many substances may act as hemolytic agents when brought into the presence of normal blood. Anything which diminishes the osmotic pressure of the plasma, such as the addition of an excess of water, will cause hemolysis. For this reason when it is necessary to inject liquid into the system, a solution of 9% sodium chloride (physiological normal salt solution) is used. It may be that the cause of hemolysis in case of reduction of osmotic pressure by the addition of hypotonic solutions is the comparatively increased pressure within the corpuscle, causing it to rupture and discharge its contained hemoglobin. Whether the above explanation is correct for the cause of hemolysis in case of dilution or reduction of the density of the plasma has not been shown, but that hemolysis may be effected in other ways is evident. There are many toxic substances, such as snake venom, products of bacterial action, or certain contents of sera of other animals, that may cause hemolysis when injected into the animal or by tests made upon drawn blood in very small quantities, in which case the reduction of the plasma could play no part.



**Hemolysins.**—The term hemolysin is applied to those substances produced by tissues of the body and contained in the body fluids, whose function is that of reacting against blood of other animals causing hemolysis of the corpuscles. The first valuable work along this line, according to McFarland, was the researches of "Belfante and Carboune" who "showed that if horses were injected with red corpuscles of rabbits, the serum thereafter obtained from the horses would be toxic for rabbits." Many other workers have shown other similar reactions. Bordet has shown that guinea pigs, after having been injected several times with from three to five cubic centimeters of defibrinated rabbit's blood, developed something in their serum which had the power of hemolyzing rabbit's blood. Ehrlich and others have since shown that there are certain substances produced by the tissues of one animal, when injected with blood from another, which gives to the blood of the first animal the power of effecting this chemico-physiological change in the corpuscles of the second animal. These substances (amboceptors) which are one class of antibodies, are not normally present in blood in sufficient quantity to produce any marked effect, but their formation may be increased by the presence of some toxic substance in the blood known as antigen. When, then, the amboceptor substance is formed in sufficient quantity, it may unite with another substance (complement) which is found normally present in blood, and these two then unite with the corpuscle, causing hemolysis. The reaction may be represented diagrammatically as follows:

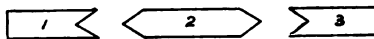

letting 1 represent the blood corpuscle; 2 the amboceptor and 3 the complement. When 2 is produced in sufficient quantity to cause the union of 1 and 3 as

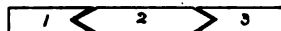

the result would be hemolysis of the red blood corpuscles.

**White Blood Corpuscles — Leucocytes.** — These blood corpuscles differ from the erythrocytes in many respects both in morphology and function. Leucocytes are living body cells in every way. They have one or more nuclei, which may be seen under the microscope if acetic acid be added or proper stains are used. They vary in number from 5,000 to 7,000 per cubic m. m. in human blood and vary in size from five to fifteen micra in diameter. Slight normal variations in the number of leucocytes may occur from exercise, digestive changes, pregnancy, etc., and abnormal variations occur in certain disease conditions. Any marked increase in the leucocyte count is known as leucocytosis and commonly occurs in the acute infectious fevers, in which the number may be increased to 30,000 or 40,000. Any marked decrease in the normal number is known as leucopenia and occurs in certain blood diseases, the anemias, and in some other conditions.

**Classification.**—Many different methods of classification of leucocytes have been used, but most physiologists now prefer the system as used by Ehrlich and Engel, who classify all white or colorless blood cells into two general divisions and these into subdivisions, as shown by the following table.

1<sup>1</sup> Lymphocytes.

1<sup>2</sup> General characteristics:

1<sup>3</sup> Possessed with only slight amoeboid movement, probably not motile.

2<sup>3</sup> Have no granules.

3<sup>3</sup> Originate from lymph glands and lymphoid tissue.

2<sup>2</sup> Classes:

1<sup>3</sup> Small.

1<sup>4</sup> Characteristics:

1<sup>5</sup> Large, symmetrical nucleus, located in center of cell.

2<sup>5</sup> About 7.5 micra in diameter.

3<sup>5</sup> Proportionately small amount of cytoplasm, not granular.

4<sup>5</sup> Constitute from 20% to 25% of the total number of white corpuscles.

2<sup>3</sup> Large.1<sup>4</sup> Characteristics:

- 1<sup>5</sup> Nucleus not centrally located, smaller in proportion to cell.
- 2<sup>5</sup> Size, from 15 to 20 micra in diameter.
- 3<sup>5</sup> Proportionately larger amount of cytoplasm, not granular.
- 4<sup>5</sup> Constitute about 1% of the total number of white blood cells.

2<sup>1</sup> Leucocytes.1<sup>2</sup> General Characteristics:

- 1<sup>3</sup> Marked power of ameboid movement.
- 2<sup>3</sup> Granules present in cytoplasm.
- 3<sup>3</sup> Originate from yellow bone marrow.

2<sup>2</sup> Classes.1<sup>3</sup> Transitional forms.1<sup>4</sup> Characteristics:

- 1<sup>5</sup> One large, lobulated nucleus.
- 2<sup>5</sup> Size, 12 to 15 micra.
- 3<sup>5</sup> Proportionately large amount of granular cytoplasm. Granules stain with neutral dyes and are therefore called neutrophilic granules.
- 4<sup>5</sup> Constitute from 3% to 10% of total number of white cells.
- 5<sup>5</sup> These cells are thought to represent a transitional stage between the large lymphocytes, but this is not positively established.

2<sup>3</sup> Polymorphonuclear forms.1<sup>4</sup> Characteristics:

- 1<sup>5</sup> Nucleus segmented into distinct lobes.
- 2<sup>5</sup> Size, 10 to 12 micra (Stewart).
- 3<sup>5</sup> Cytoplasm granules and stain with neutral dyes.
- 4<sup>5</sup> Constitute from 60% to 75% of the total number of white cells.

5<sup>5</sup> These cells are very motile and highly phagocytic.

6<sup>5</sup> Eosinophiles or eosinophilic leucocytes, a sub-group of the polynuclears, are similar to the above, differing in that they have larger granules, which stain with eosin. Size, 12 to 15 micra in diameter (Stewart).

### 3<sup>8</sup> Mast Cells.

#### 1<sup>4</sup> Characteristics:

1<sup>5</sup> This group differs from the polynuclear in that their granules stain with the basic dyes. They constitute less than 1% of total number of white cells. The basophiles are about 10 micra in diameter. (Stewart).

**Functions of Leucocytes.**—Leucocytes may be called the wandering cells of the body. They have the property of being able to pass through the capillary walls and in this way come in immediate contact with the various tissue cells. Because of this ability those which are possessed with the greatest ameboid movement may work their way to any tissue, where, in case of inflammation, they are attracted to the part probably by a specific attraction known as chemotaxis.

1. These cells have the property of ingesting foreign substances and by this phagocytic action serve to destroy bacteria, products of tissue disintegration, etc., and may be properly called the scavengers of the body. This property of phagocytosis, which was discovered principally by the researches of Metschnikoff (1892) has been shown to be a method of body protection against invading bacteria. These cells also have the property of secreting certain substances known as bacteriolysins, which are both bactericidal and antiseptic to toxins of bacteria. The recent researches of Wright have shown that the leucocytes depend for their phagocytic activity upon other substances known as opsonins (taken from *OPSONO*, and meaning "I prepare food for"). It may be thought of as a kind of bacterial sauce, in that it sensitizes

the bacteria and renders them more easily ingested by the leucocytes. There are many other such substances formed in the body by various structures, which protect in various ways against various kinds of poisonous substances in the blood and other body fluids. It has been shown that, if an animal is experimentally inoculated with a small quantity of bacteria the formation of these antibodies is increased, and that, if the inoculation be repeated several times, the antibodies in the body fluids will continue to be increased until a condition of immunity or complete resistance is established. This is another example of a physiological response to a demand for a function or a method of development of a protective adaptation, and is known as a "biological reaction."

2. Leucocytes take part in blood coagulation, as will be discussed later.

3. By their constant disintegration and dissolution in the blood stream they assist in maintaining the normal protein composition of the blood.

4. They probably aid in the absorption of fats in the intestine, and they assist in some way in the absorption of peptones.

**Blood Plates.**—These small bodies present in blood vary in size from particles so small that they can scarcely be detected with the microscope to about five microns in diameter. They are usually circular in form and homogeneous in appearance. These bodies readily disintegrate when removed from the blood. There is so little known about these bodies as regards their origin, function, or relation to other blood elements, that little can be said. They probably take part in the process of coagulation by forming prothrombin, as will be discussed under that subject. It is not known whether they are distinct cells, maintaining a separate and independent existence, or whether they represent disintegration products of the blood cells. The probable normal number of blood plates is about 300,000 per cubic m. m., which is said to be markedly reduced in disease affecting other blood corpuscles.

## CHAPTER II.

### CHEMICAL PROPERTIES OF BLOOD.

Because of the relation of the blood to the body and its functions in supplying tissue with good material and relieving the cells of their waste, it may readily be seen that the blood will necessarily contain a great variety of chemical constituents. The chief constituents of blood are water, oxygen, carbon dioxide and nitrogen in various forms.

The following table taken from Howell gives Abderhalden's results of quantitative chemical analysis of blood:

	1000 Parts, by Weight, of Blood Contain	1000 Parts, by Weight, of Serum Contain	1000 Parts, by Weight, of Corpus- cles Contain
Water	810.05	923.98	644.26
Solids	189.95	76.02	355.75
Hemoglobin	133.4	.....	327.52
Protein	39.68	60.14	9.918
Sugar	1.09	1.82	
Cholesterin	1.298	0.709	2.155
Lecithin	2.052	1.699	2.568
Fat	0.631	1.051	
Fatty acids	0.759	1.221	0.088
Phosphoric acid: as nuclein	0.054	0.016	0.110
Na <sub>2</sub> O	3.675	4.263	2.821
K <sub>2</sub> O	0.251	0.226	0.289
Fe <sub>2</sub> O <sub>3</sub>	0.641	.....	1.573
CaO	0.062	0.113	
MgO	0.052	0.040	0.071
Cl	2.935	4.023	1.352
P <sub>2</sub> O <sub>5</sub>	0.809	0.242	1.635
Inorganic: P <sub>2</sub> O <sub>5</sub>	0.576	0.080	1.298

**Blood Proteins.**—Three proteins are present in blood, viz., fibrinogen, serum-globulin or paraglobulin, and serum albumin.

The chemical properties of these proteins may be found discussed in texts on physiological chemistry. Their functions only will be given here.

Fibrinogen is always present in blood and lymph, but only in small quantities (.2% to .4%). Since this protein takes an active part in the process of coagulation, entering into the formation of fibrin, it is not found in the serum. The functions of fibrinogen other than its property of assisting in blood coagulation are not definitely known. The origin of this protein is also unknown, but there is some reason to believe it may be formed in the liver.

Serum-globulin is a normal constituent of blood, lymph, and in all body exudates, normal or pathological. Paraglobulin is present in human blood plasma in quantities varying from 3% to 3.5%, and is also present in blood serum in even greater quantities. The source of this protein is also not well understood. It comes either from the absorbed proteins from the digestive tract or the disintegration of leucocytes.

Serum-albumin like serum-globulin is present in blood, lymph, extravascular lymph, and all exudates, normal or pathological. Human blood contains from 3% to 5% of this protein. It originates from the digested proteins of the intestinal tract, after a series of complex changes from peptones, proteoses, etc. Serum-albumin is probably the chief functional protein in tissue building.

### **BLOOD COAGULATION.**

If blood is allowed to escape from the vessels a change is noted in a short time, characterized by the formation of a solid mass from which a straw-colored fluid, the serum, is expressed by contraction of the solid mass or clot. This process is known as coagulation. The clot consists of fibrin and red and non-motile leucocytes. The fibrin is formed from fibrinogen of blood plasma. If freshly drawn blood be whipped rapidly with twigs or a glass rod the fibrin is deposited on the rod, thus preventing clotting. The remaining serum (whipped blood) contains the corpuscles, and if entirely defibrinated will not coagulate. The process of coagulation may be observed under the microscope by placing a drop of fresh blood on a glass slide and covering it with a cover slip or by making a hanging-drop preparation. After some minutes

a careful examination will reveal the minute fibrin threads among the corpuscles.

**Coagulation—How Caused.**—A great many theories of blood coagulation have been advanced, but it is considered best to leave these to the history of physiology rather than expect the student to learn them now. The process of clotting is caused by fibrin, which results from the action of thrombin upon fibrinogen. The various theories are concerned with the explanation of how this change is effected. The modern theory explains this by stating that there is a substance (prothrombin) in the blood, which results from the degeneration of leucocytes and blood plates. This prothrombin, by the action of calcium salts, is changed to thrombin and the thrombin reacts with fibrinogen, forming fibrin. The fibrin produces the clot as stated above, and the degeneration of this clotted material continues to form more prothrombin, and thus the process is continued.

By some authorities it is believed that the thrombin is present in the blood in an inactive form known as thrombogen, and that this must be changed to an active form by the action of calcium salts and an organic substance supposed to be thrombokinase. This kinase is supposed to be produced by certain tissue cells and cellular elements of the blood and a necessary factor in blood coagulation. It is assumed that in case of injury causing bleeding on exposure the blood cells and plates and possibly the injured tissues produce thrombokinase, which in association with the calcium salts causes coagulation, as explained above. Thrombokinase has never been isolated nor has it ever been demonstrated that an organic kinase is necessary in addition to the calcium for the activation of the disintegrated cellular elements, the prothrombin. Howell and his co-workers have explained that activation of prothrombin is not necessary, and that the blood is kept liquid in the vessels by the action of a substance known as antithrombin, which prevents the calcium from (activating) changing the prothrombin to thrombin. They assume that when blood is shed or tissue is injured another substance is produced which neutralizes the antithrombin, and the process of formation of thrombin and



fibrin continues as explained above. The following diagram serves to illustrate the general plan of blood coagulation:

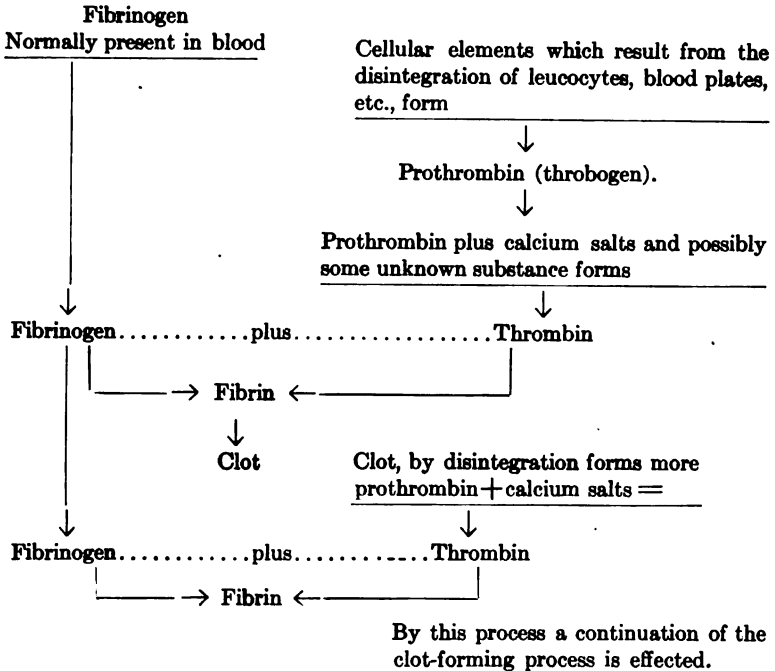

The clotting time of blood varies with certain conditions, as follows: There is an individual variation for different persons, the cause of which is not well understood. Because of this fact, since clotting prevents loss of blood by hemorrhage, those individuals in whom the blood does not clot readily are often prone to excessive bleeding from the slightest injury, the condition being known as hemophilia. At room temperature the blood begins to coagulate in from five to ten minutes after it is drawn, but complete coagulation does not occur for several hours (12 to 48). Cooling increases the clotting time, and heating to 60° C. coagulates the fibrinogen and prevents clotting.

Human blood is affected as regards its clotting time by certain disease conditions. In the infectious fevers, for example, the clotting time is usually greatly increased.

**Methods of Increasing Coagulation.**—In cases of hemorrhage, hemophilia, etc., it may become necessary to hasten the process of clotting: 1. By the application of heat or cold packs to the place of injury, the blood may be made to clot more quickly and thus stop the bleeding; 2. by the application of any substance such as a sponge or a piece of gauze, which increases the surface area of the blood exposed and usually is sufficient if the wound is not large; 3. certain chemical substances, e. g., thrombin or tissue extracts, may be of use in case of hemorrhage. Gelatin injected hypodermically is one of the most common methods of controlling hemorrhage.

**Methods of Preventing Clotting.**—1. By quickly cooling freshly drawn blood to a temperature of  $0^{\circ}$  C., or nearly so, it may be kept liquid for an indefinite length of time; 2. If blood be carefully drawn from an injured vessel into a dust-free and dust-proof, paraffin-lined vessel, clotting does not occur for several hours; 3. there are many chemical solutions, such as magnesium sulphate 25%, sodium sulphate (a half saturated solution), which prevent clotting, sodium oxalate, sodium citrate (10%), and some other similar chemicals prevent clotting by decalcification of the blood; 4. the injection of peptone plasma, which is prepared from the blood of animals previously injected with peptone solution, retards blood coagulation; 5. the injection of leech extract (hirudin plasma) also retards coagulation.

**Intravascular Clotting.**—It has been repeatedly shown that normal blood will not coagulate in a normal, uninjured blood vessel. This may be shown by ligating a large vein in two places in a living animal. The blood contained between the ligatures will not clot for several days if no injury is done to the vein. This is explained by several possible theories: 1. That thrombin is not present in normal blood in the active form in sufficient quantities to cause clotting; 2. thrombokinase is not present; 3. cellular elements from tissue disintegration are not formed in sufficient

amounts, i. e., their formation is only gradual and therefore the prothrombin resulting from degenerations is not sufficiently active to form thrombin. In case of injury the tissue extractives from the injured tissue and prothrombin are deposited quickly; 4. the theory of the existence of a substance known as antithrombin which prevents the action of tissue extracts, etc., is supported by the fact that the injection of tissue extracts does not cause intravascular clotting. It is thought that leech extract, peptone plasma, etc., mentioned above, resemble antithrombin in that they counteract or restrain the action of thrombin. Foreign material of any kind, such as dust particles in air or air itself, may cause clotting in the blood vessels. It may be that these substances cause the formation of disintegration products—prothrombin, thrombin, etc.—and thus effect blood coagulation. The same process may result from any injury to the inner coat of the vessels. Certain chemical substances—solutions of calcium salts—may, when injected, cause intravascular clotting.

#### QUANTITY AND DISTRIBUTION OF BLOOD.

The total quantity of blood in the body is estimated to be about 7.7% of the body weight. Various methods have been used for determination, but in the human it is not an easy task. Bischoff has determined the quantity of blood of several guillotined criminals, with the results as given above. At this percentage, a man weighing 150 pounds would have about 11.5 pounds, or 5 kilograms. Of this amount, as has been shown by experimental work on dogs, about half of the blood can be lost by hemorrhage, and if the animal is properly cared for, recovery will result. I have seen complete recovery result in a dog weighing 60 pounds, after drawing more than a liter of blood.

**Blood transfusion** is the process of transferring blood from one animal to another. It has been used to some extent clinically for the support of a patient undergoing a surgical operation, but is little used because of certain dangers which may result.

It is usually considered that if the blood of one species be

transfused into the blood stream of another species the result will be death to the second animal, the cause being due to hemolysis. The results of such transfusion depend upon several conditions, such as the quantity of blood transfused; the method employed; the condition of the animal from which the blood is taken, etc. In some cases a very small amount of blood will cause hemolysis, but if the operation is done in such a way as to prevent clotting, or if defibrinated blood be used, the result is not fatal in animals of the same species. In some cases blood transfused from animals of one species into the veins of animals of other species is not followed by fatal results. If, for example, dog blood is transfused into cats, no evil effect follows, nor is cat blood fatal to dogs. This, however, is not generally true, for in many instances the transfusion of small quantities of the blood of one animal into another produces hemolysis. (See hemolysins.)

In those cases in which blood transfusion may safely be practiced, such as from one kind of dog to another or from dog to cat, a short period of time is usually necessary for the animal to become normal again, but in some instances the operation is followed by almost no noticeable change. A great many physiological principles have been learned concerning circulation and blood changes by methods of blood transfusion, such as the effects of antibodies, etc., but this belongs under another heading.

**Regulation of the Quantity of Blood.**—The circulation of the blood was discovered by Harvey in 1628. This opened the way for further research, and probably no other subject has undergone as much variation in theory since that time as has the science of physiology. It is even yet doubtful if we should call it a separate science, as comparatively so little is known. It was formerly believed that if an individual lost as much as a few ounces of blood, this was almost fatal. Then came the bleeding era, when for almost any abnormal condition the patient was relieved of a quantity of blood, but almost nothing was actually known regarding the physiology of blood-letting. It is now well known that the body machine has a method by means of which the proper quantity of all body fluids is regulated, and there is very seldom if ever an excuse for bleeding.

The kidneys, skin, and other excretory organs, the physiology of which is to be given later, so regulate the quantity of blood in the body that the proper amount is maintained at all times. If, as in case of the loss of a quantity of blood by hemorrhage, any great amount is lost—from a pint to a quart or more—there are symptoms of collapse, and blood transfusion may be practiced. The use of physiological salt solution injected intravenously, subcutaneously, or per rectum, as the condition of the case demands, is usually as effective and always much safer than blood transfusion. This may be shown experimentally by bleeding an animal until the pulse is very faintly felt, and slowly injecting the same quantity of normal salt solution as blood removed, or until the pulse is full and the pressure is normal. Such animals will show symptoms of weakness until complete regeneration of the original amount of blood elements has occurred, which requires from one to three weeks in the dog.

**Distribution of Blood.**—Blood distribution is determined by the functional need of the various structures supplied. The heart, lungs, and great vessels contain one-fourth; the liver, one-fourth; the resting muscles, one-fourth, and the remaining one-fourth is distributed to the other tissues of the body.

It may readily be seen that there is a functional demand for a large quantity of blood to be constantly supplied to the lungs, that the proper oxygenation may be effected. The functional demand of the liver will be better understood after the functions of the liver are noted. In the embryo and foetus the liver performs an important function as a blood-forming organ, and grows excessively large in proportion to other body parts. After birth the liver has many important functions, such as storing glycogen, detoxication of the blood, etc., which demand a liberal blood supply.

Resting muscle also demands a good blood supply for the restoration of its glycogen and oxygen after functional activity (see sources of muscle energy). It may therefore be seen that the demand of function and the development of structural relations to meet this demand are the determining factors in the distribution of blood in the body.

## CHAPTER III.

### LYMPH.

**General Properties.**—Lymph is a colorless or slightly yellowish fluid except after meals, when it is cloudy or milky because of the presence of varying quantities of finely divided fats, the fat constituting the basic part of the chyle, which is the substance taken up by the lacteals from the intestine during absorption. Lymph varies in its composition, according to the location in the body from which it is obtained. Lymph from the thoracic duct varies according to conditions of the animal, the length of time since it has been fed, and the kind of food eaten. If the animal has recently had a meal of fats the lymph is rich in finely divided fat. It is slightly alkaline in reaction and has a specific gravity of about 1.915. It clots upon standing, producing a colorless clot of fibrin and serum very similar to that of blood. Lymph from the thoracic duct contains about 6% of solid matter, which consists chiefly of proteins, fibrinogen, paraglobulin and serum albumin. The inorganic salts are about the same in quality and amount as in blood.

**Where Found.**—Lymph is found in the lymph vessels, in extravascular spaces—all tissues of the body being thoroughly bathed in this fluid—and it is also found in the various vascular sacs, where it performs functions of protection and lubrication, and furnishes in some cases nourishment to the surrounding structures. This type of extravascular lymph, such as pericardial fluid, synovial fluid, cerebro-spinal fluid, aqueous humor, pleuritic fluid, etc., varies somewhat in its composition from vascular lymph.

**Origin and Formation of Lymph.**—The fluid of the lymph and the salts come from the plasma of the blood by a process of filtration or secretion, and this is not as yet known. There are good reasons for both theories, some of which will be briefly given:

The secretion theory is supported by the following evidence: There are certain substances known as lymphagogues, which when injected into the blood stream cause an increase in the formation of lymph. Lymphagogues are generally divided into two classes: Those of the first class, such as peptone; extracts of leaches (head and liver); extracts of muscles of crayfish; albumin, etc., and those of the second class, the crystalloids, such as solutions of salt, sugar, etc. It has been shown by Starling that the intravenous injection of lymphagogues of the second class produces an increase in the formation of lymph by attracting water from the tissues, causing a hydræmic plethora, without increasing the arterial pressure.

The fact that lymphagogues increase the formation of lymph was considered by Heidenhain, the chief supporter of the secretion theory, as the strongest argument in its favor.

The theory of filtration is supported by the fact that certain conditions which increase the pressure in the capillaries are followed by an increase in the formation of lymph. This has been demonstrated by ligation of the vena cava, which, since the flow of blood is prevented, increases the pressure and the operation is followed by an increase in lymph formation. By the injection of large quantities of normal salt solution, thus increasing the blood pressure, the lymph flow is increased. This argument is met by the adherents to the secretion theory by the fact that secretagogues cause an increase in the formation of lymph without causing an increase in the blood pressure.

We may summarize by saying that from the above and much other evidence in favor of both sides, it is quite probable that both secretion and filtration play important parts in the formation of body lymph.

**Lymph Vessels.**—The formation of the various lymph vessels and their courses belongs to the subjects of histology and anatomy, and the student is urged to consult texts on these subjects. The lymph vessels differ in many ways from blood vessels. Their walls are thinner, they have valves opening in the direction of the veins toward which the lymph vessel is directed, and they are

at various points collected into clusters or nodes, where they form glands. Certain constituents of the lymph, such as the lymphocytes, are probably produced in these glands. There are two large lymph trunks, which empty their contents directly into the venous system. The thoracic duct, which extends from the receptaculum chyli or cistern of the chyle to the neck region, empties the chyle which has been collected by the lacteals from the villi of the intestine into the left subclavian at the junction of the internal jugular vein. The right lymphatic duct drains the right side of the chest, head and neck into the large veins of the right side. All lymph vessels ultimately empty into one of the large lymph channels or into the venous system directly. The serum of the blood, which escapes through the capillary walls, is taken up by the smaller lymph vessels, and after a time is carried back to the blood stream.

**Lymph Flow. Causes of.**—Since there is no heart for maintenance of the flow in the lymph vessels, other factors are responsible for this function: 1. The increased pressure in the tissue spaces causes the lymph to flow into and through the small lymph vessels; 2. The contraction of muscles squeezes the lymph from the smaller vessels; and 3. The presence of valves in the lymph vessels which prevent the back flow of lymph causes its flow towards the large veins; 4. The variation in pressure in the thoracic cavity caused by respiratory movements—the so-called suction action—also assists in the flow of lymph.

**Functions of Lymph.**—Since the blood does not come in direct contact with living body tissue cells anywhere, but is held separate from them by capillary walls, there is in most body structures another medium of cell supply needed. In a few tissues, such as the lungs and liver, the tissue cells lie in immediate contact with the single-layered walls of the capillaries, and thus these cells may be directly supplied with nutrition from the blood and relieved of their wastes in a similar way. Many tissues are very avascular, and the cells of such tissues must receive their supply from tissue fluid or lymph, which is that portion of the blood which has escaped into the tissue spaces from the blood stream.



**Cerebrospinal Fluid.**—This is normally a clear, colorless fluid rich in sodium chlorid; contains small quantities of albumin, but contains no morphological blood elements; no fibrinogen and does not clot, which characteristics distinguish it from other lymph and blood. It is secreted principally by the cuboidal cells of the choroid plexus, a fold of pia mater which projects into the lateral ventricles. It has been shown that injection of extracts of choroid material increases the formation of cerebrospinal fluid. It has a specific gravity of about 1.006, and is constantly being secreted at the rate of about six drops per minute.

This fluid may be found circulating between the arachnoid and pia mater, and continuing down the spinal cord. From the lateral ventricles, where it is produced, it passes to the third ventricle through the foramen of Monroe, and from here to the fourth ventricle by way of the aqueduct of Sylvius, and from the fourth ventricle it passes through the foramina of Magendie, Retzius and Key to the subarachnoid space; from the subarachnoid space a part of the fluid escapes into the sinuses of the dura mater by way of villous projections known as the Paccionian bodies. It also escapes by way of the projections of the arachnoid, which extends outward around the cranial and spinal nerves. These projections are continuous with the lymphatics, and seem to have some function in supplying the nerve trunks with lymph.

The functions of cerebrospinal fluid may be considered under separate headings, as follows: First, protection to the brain, spinal cord and nerve trunks from traumatic injury; second, this fluid forms an adjustable cushion for the brain and cord, which regulates the pressure about these structures by secretion and by drainage in such a way that the optimum pressure is properly regulated. Since the brain cannot withstand compression and since it is contained in a resisting case of firm bone, the increase in brain volume from congestion or from increased systemic blood pressure must be compensated for in some way, and the adjustable cushion of cerebrospinal fluid does this. These principles may be better understood when it is known that the withdrawal of a large quantity of cerebrospinal fluid, or an in-

inflammation preventing the normal escape of fluid from the brain or cord, which in either case would markedly vary the cranial pressure, is always followed by cerebral symptoms. Since the secretions of the posterior lobe of the pituitary body are emptied chiefly into the cerebrospinal fluid, and since it is highly probable that this secretion is both detoxicatory and has some influence upon the spinal autonomic nerves, it may be that the presence of normal quantities of cerebrospinal fluid increases the resistance of the cord to infections, and the normal flow about the nerve trunks regulates the functional activities of the nerves.

**Osteopathic Considerations.**—From the above physiological facts it would seem that lesions, subluxations, or rigidities of spinal segments would materially interfere with the drainage of cerebrospinal fluid from the cord. Lesions of the atlas or axis might prevent the drainage from the cranium, and either of these conditions would result in a failure of the regulation of the pressure in and about the brain and cord. This would certainly be followed by a variation of the functional activities of these structures. Dr. A. T. Still holds that the function of certain visceral structures depending upon the nerve supply of the spinal autonomies (such as the gut in case of typhoid fever, etc.) are largely influenced by the flow of cerebrospinal fluid, and this seems reasonable when we consider that this fluid is normally drained out by way of the nerve trunks, and that it does seem to give increased nerve tone to the sympathetics. Every osteopathic physician who has had much experience in treating acute infectious fevers knows that a thorough treatment of the spine is practically always followed by rest and sleep. That such treatment normalizes or tends to normalize the pressure to the cord and brain and thus lessen the cerebral symptoms is firmly established clinically.

It may be that the detoxicatory and antibody-forming properties of the cerebrospinal fluid is due in part to the secretions of the pituitary body. If so, any failure of the normal drainage of the fluids into or from the meninges of the cord would reduce this resisting mechanism, and spinal lesions would surely reduce the drainage.

## CHAPTER IV.

### ORGANS OF CIRCULATION.

**The Heart.**—A study of the ontogenetic and phylogenetic development of any structure greatly aids in the understanding of its normal functions, and a thorough working knowledge of Haeckel's biogenic law will be found of great value to the student who wishes to know "the why of things physiological".

The study of the evolutionary descent of the mammalian heart is, in my opinion, of greater value in the understanding of its physiology than all other facts and theories gained from research.

The primitive function of circulatory organs was not that of maintaining a blood flow, for there was and is no blood in the lowly forms of life, and just as "ontogeny repeats phylogeny" there is no blood in the higher forms of living animals at the time the heart begins to beat in the embryo. The function of that little mass of contracting cells arranged about a common body tube in the lowly forms of life was that of imperfectly circulating or keeping the body fluids in motion, that all tissue cells might receive a fluid medium from which to collect nutrition and into which the wastes might be excreted. The primitive excretory apparatus, the pronephros, was closely associated functionally with this simple circulatory mechanism that the wastes from the cells might be carried away. There were no valves in the primitive tube-heart, but the direction was given to the circulation by the wave of contraction beginning at the end of this mass of contractile cells and moving continuously towards the other end, very much as a wave of peristalsis moves through a segment of gut, thus causing the body fluid to move in one direction.

In the primitive body fluids there are no differentiated morphological structures such as corpuscles, which develop for the per-

formance of special functions, and this body fluid cannot, therefore, any more be properly called blood than can the simple contracting tube which causes its flow be called a heart. It is by a process of slow development and gradual differentiation of the various parts that these simple structures attain the form of the highly complex structure, the mammalian heart.

These few hints are given here on the origin of the heart and circulation, that the reader may be better able to understand certain explanations that are to follow.

**The Mammalian Heart.**—In the mammalian or four-chambered heart it is well to consider the structure as a double mechanism, or two distinct hearts, since the right and left sides of the heart are functionally concerned with different parts of the circulatory process. By reference to the cut on page 47 this may be clearly seen. Each side of the heart consists of an auricle or upper chamber, which empties its contents through the valve into the ventricle below. The walls of the auricles are very thin, and their capacity is markedly small in comparison to that of the ventricles. The reason for this is the difference in the demand of function of the two structures. The blood, for example, is received into the auricles from veins in which the pressure is very little or nothing, and there is therefore no need of valves guarding the openings of these veins into the auricles. Furthermore, the only work of the auricle is that of completion of the filling of the ventricles, and the resisting pressure in the auricles is from 14 to 20 millimeters of mercury. The strong auriculo-ventricular valves, preventing the blood from flowing back into the auricles when the ventricles contract, protects the thin-walled auricles and their entering veins from the effects of back pressure. The ventricles, because they must force their contents against a much greater resisting pressure, must necessarily be stronger and their walls are therefore very much thicker than those of the auricles. The walls of the left ventricle are about four times thicker than those of the right ventricle. This is because the left ventricle must force the blood against the resistance offered by the entire systemic circulation—the greater circulation, while the blood from the right ventricle is forced only through the lungs—the lesser circulation.

Because the blood discharged from the right ventricle, after having passed through the lungs, must again pass through the left heart, the two ventricles must have the same capacity. The capacity of each ventricle is from 130 to 150 cubic centimeters when the heart is relaxed. During contraction of the ventricles about half of this quantity is expelled into the arteries. A fibro-tendinous ring separates the auricle from the ventricle, and from this ring most of the muscle fibres constituting the walls of the heart arise. The musculature of the heart is arranged in two layers, circular and longitudinal. The circular fibres are continuous around both auricles and increased in thickness about the openings of the veins. The musculature of the heart should be carefully studied from a text on anatomy, in order that the functions of the different layers may be understood.

**Valves of the Heart.**—The direction of the blood flow through the heart is determined partly by the direction of the contraction wave, but principally by the valves, which prevent the back flow. These valves are four in number, and guard the openings between the auricles and ventricles and prevent the back flow of the blood from the large arteries into the ventricles. The auriculo-ventricular valves consist of tubular membranes which are continuous with the endocardium, or inner layer of the heart, and are attached at their base to the auriculo-ventricular ring. The valve flaps consist of a base or central part, composed of fibrous and elastic tissue covered on both sides by endocardium. These valves project downward into the ventricles. The valve flaps are held in position and kept from being forced back into the auricles by many small tendinous cords (*chorda tendinæ*) which arise from small projecting parts of the wall of the ventricle, the papillary muscles. During contraction (systole) of the ventricle these cords are drawn down, which action draws the valves more tightly together and prevents their being forced upward by the pressure of the blood in the cavity of the ventricle. The action of the valve is further aided by the contraction of the muscles of the fibro-tendinous ring at the base of the heart. This action reduces the size of this orifice during systole. The valve between

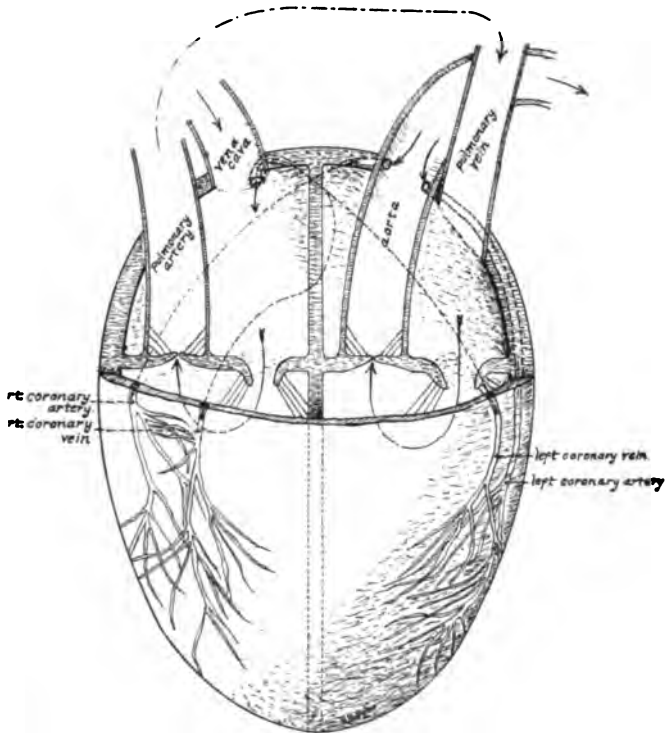

FIG. 1.—This diagrammatic figure illustrates the blood flow through the heart and the blood supply to the heart musculature by way of the coronary circulation. Beginning at the left side of the figure above, the blood is shown to enter the right auricle of the heart from the vena cava. The second arrow shows the entrance of the coronary vein, which drains the blood from the musculature of the heart which has been supplied by the coronary arteries. From the right auricle the blood passes through the tricuspid valve into the right ventricle, as shown by the arrow, and from here it passes through the pulmonary semilunar valve into the pulmonary artery, which carries it to the lungs for oxygenation. The blood returns from the lungs by way of the pulmonary veins, which is diagrammatically shown in the figure. From the pulmonary veins the blood enters the right auricle of the heart, and from here it passes through the mitral or bicuspid valve into the left ventricle. The blood leaves the left ventricle through the aortic semilunar valve and enters the aorta. The coronary arteries are shown as being given off from the aorta, which is correct, these arteries being the first branches of the aorta, but instead of leaving the aorta at the point shown their openings really lie under the folds of the semilunar valves. Because of this arrangement the pulmonary valves fold back over these openings during ventricular systole and the openings to the coronary arteries are closed until the back pressure of the blood in the artery closes the valves. When this occurs the blood in the aorta fills the coronary arteries and the supply to the heart is effected during diastole of the heart, the significance of which has been explained elsewhere.

the right auricle and the right ventricle—the tricuspid—has three flaps, while the valve between the left auricle and the left ventricle—the bicuspid or mitral—has only two flaps. The student who experiences difficulty in remembering this may be helped by the key, “Martin Luther, the reformer—mitral left, tricuspid right.”

The valves guarding the large arteries—the semilunar—consist of three flaps or cups, which prevent the blood flowing back into the ventricles after systole or contraction of the ventricles. These valves are comparatively much stronger than the auriculo-ventricular valves, and are therefore less often involved in diseased conditions of the heart. These valves are closed at all times when the blood pressure in the arteries is greater than in the ventricles. They are only open during the period of ventricular contraction and are held tightly closed by the pressure in the arteries forcing their free edges together during diastole.

There are no valves at the openings of the large veins into the auricles. The contraction of the muscular rings at the openings of these veins performs the functions of valves, in that this action prevents any back flow of blood into the veins.

**The Pericardium.**—The heart is suspended in a tough fibrous membrane, the pericardium, which is attached below to the central tendon of the diaphragm and attached above to the trunks of the large arteries. The pericardium has an inner lining of endothelium which is continuous with the outer covering of the heart. Between these two layers the pericardial fluid—a form of extravascular lymph—is found, which lubricates the walls, thus preventing friction and furnishing a water cushion for the protection of the heart.

**Blood Pressure in the Heart.**—Many different methods have been devised for measuring the endocardiac pressure, but all have certain sources of error. The measurement of such blood pressures is very difficult, because of the quick rise and fall of the pressure caused by the contractions and relaxations of the heart muscle. The pressure in the left ventricle is the greatest of all of the chambers of the heart, because it is this part that has to

force the blood into the entire system of arteries and capillaries. The blood pressure in the left ventricle of a dog has been found to be from 130 to 200 millimeters of mercury during systole, and it is probably much higher than this in the human heart. The pressure in the ventricle must be great enough to overcome the resistance in the artery and to force the contained blood into it.

The pressure in the right ventricle is much less than that in the left ventricle. The pressure in the pulmonary artery is about one-seventh or one-eighth that of the pressure in the aorta, and considering the pressure in the aorta to be 150 millimeters of mercury, the pressure in the pulmonary artery would not be more than 25 millimeters of mercury; the pressure of the right ventricle would therefore be from 40 to 60 millimeters of mercury.

The pressure in the auricles is much less than in either of the ventricles, since they have only to force the blood into the ventricles to complete their distension after they have been partly filled. The pressure in the auricles varies from 10 to 20 millimeters of mercury.

**The Cardiac Cycle.**—The cardiac cycle consists of the various events of one heart beat which occur between two points of the same phase, and may be given as follows: The beat of the heart begins with a simultaneous systole of the auricles—about one-tenth of a second—which is followed by a pause of about one-tenth of a second. The contraction of the auricles is followed by the systole of the ventricles—about three-tenths of a second—the blood being forced into the large arteries. The period of diastole or rest lasts about four-tenths of a second. The effects and changes occurring during such a cycle are as follows: The auriculo-ventricular valves are closed only during the period of contraction of the ventricles, while the semi-lunar valves are closed all the time except during contraction of the ventricles, when they are open to allow the passage of the blood into the large arteries. During ventricular systole the blood is forced from the right ventricle into the pulmonary artery and into the capillaries of the lungs. The increased pressure in the capillaries of the lungs because of this maintains an almost even pressure back to the left



auricle through the pulmonary veins. During systole of the left ventricle the blood in the arteries of the system is forced onward to the systemic capillaries and finally back to the right auricle by way of the venous system.

The elastic retraction of the lungs causing a negative pressure in the thoracic cavity assists the flow of the blood from the large veins into the auricles. This so-called suction-pump action materially assists in the "drawing" of the blood and lymph towards and into the thoracic vessels of the thoracic cavity, thus assisting the heart, and during the resting period of the heart the blood is continually flowing into and filling the auricles. Since the auriculo-ventricular valves offer little or no resistance, the blood from the auricles flows on through into the ventricles, partially filling them. During the contraction of the auricles the blood is forced into the ventricles, distending them. The auriculo-ventricular valves now float into position, and as the ventricles begin to contract these valves are forced tightly together, preventing the back flow into the auricles. The contraction of the ventricles begins very suddenly, and the outflow of the blood from them begins soon after the beginning of the ventricular systole. During diastole "the pressure in the ventricle cavity is quite small (only 2 or 3 millimeters of Hg.) there is a pressure in the aorta of 50 to 80 millimeters of Hg." (Starling.) The pressure in the ventricles must be raised above this pressure in the arteries before the semi-lunar valves can be forced open. As soon as the ventricles have ceased contraction the pressure in the arteries closes the semi-lunar valves.

**Causes of Heart Beat.**—Two theories, the neurogenic and myogenic, are advanced for the explanation of the causes of heart beat, which will be briefly discussed.

Supporters of the neurogenic theory offer the following evidence of its value: The existence of an automatic motor center at the junction of the auricles and large veins, which seems to be responsible for the initiation of the contraction wave. Adherents of this theory assume that the excitation of the stimulus arises within this nerve mechanism, and that these nerve cells constitute

the automatic motor center of stimulation for heart muscle. The contraction wave spreads from these points downward over the auricles and thence to the ventricles, and it is supposed that the impulses are transmitted by way of the axones extending from these nerve cells. These nerve centers with other secondary or subordinate centers constitute the intrinsic nerve mechanism of the heart, which, according to this theory, is responsible for the spontaneous origination and progression of the rhythmical activity of the heart. It is assumed that this equal stimulation of the musculature by the action of these nerve fibers is responsible for the normal co-ordinated movements of the heart, such as fibrillar contractions. Results of physiological research have in many ways borne out the above theory, but histologically there is insufficient confirmatory evidence.

It is true that most of the phenomena of the heart beat and its regulation can be explained by this theory, but, as will be shown, the same is true of the myogenic theory. Again it seems that no positive facts have been offered against the theory. On the other hand, there is no positive evidence that the nerve supply of the heart is actually causative of its functional activity. The most suggestive argument in favor of the neurogenic theory is the fact that if a needle be thrust into the normally functioning mammalian heart (a certain part of the ventricle and known as the puncture of Kronecker) the regularity of the contraction of the ventricles is disturbed and fibrillar contractions result. This area is not a large one, and if the needle thrust does not pass through this specific "center" the regular co-ordinated beat of the heart is not affected. The structural nature of this "center" has never been determined, and since the puncture so often fails to produce the irregular contractions, there is no positive proof that it controls or initiates the stimulus causative of the heart beat.

A series of experiments made by Carlson on the horseshoe crab shows quite conclusively that in this case, at least, the rhythmical contractions depend upon the intrinsic nerve plexuses, but whether these facts can be applied to the functions of the mammalian heart is questionable.

**The Myogenic Theory.**—By this theory it is assumed that the heart is possessed with the property of rhythmical contraction, and that this inherent property of the protoplasm has been developed in answer to a demand of function until it fulfills the functional requirements. It is assumed that this power of rhythmicity has been developed most highly at the portion of the heart where the large veins enter the auricles, and now by reference to the brief notes on the phylogensis of the heart in the beginning of this chapter, a reason for this may be clearly seen. It may also be seen why the wave of contraction spreads from this point first to the auricles and then to the ventricles as one progressive movement. It must be remembered that in the heart, as well as in the intestine, the muscular movement is that of a peristalsis—consisting of a gradually progressive wave of dilation followed by constriction. In the intestine and in the primitive heart this may be readily demonstrated, but in the more highly developed hearts the special structural arrangement is such that the wave becomes segmented rather than regularly progressive.

The chief evidences of the myogenic theory will be briefly given:

1. A study of the anatomical arrangement of the various muscular layers of the heart will show that it is structurally adapted to the action of a progressive wave of contraction. The auriculo-ventricular bundle, connecting the musculature of the auricles with that of the ventricles, makes the continuation of a muscular wave possible.

2. The nerve mechanism connecting the auricles and ventricles may be removed without disturbing the normal rhythmical contraction of the heart, thus tending to disprove the neurogenic theory.

3. Anything that directly affects the auriculo-ventricular bundle, thus preventing the regular progression of the wave, disturbs the rhythmical contraction of the heart. It has been shown by Stannius that if ligatures be placed about the heart at various places the rhythmical contractions are disturbed. In various other ways, such as by section or otherwise, if the normal

connection of this auriculo-ventricular band is disturbed the heart rhythm is interfered with. Adherents to the myogenic theory have endeavored to explain this by arguing that this band contains nerve fibres which are effective in the transmission of impulses.

4. It has been shown by Englemann that a heart may be sectioned in various ways, which sections would surely cut all nerve connections, but if small portions of intervening muscle remained between a contraction wave would progress from above downward, passing over these muscular bridges, which cannot be explained by the neurogenic theory:

5. The theoretical reasons as given above for believing in the autonomic rhythmical properties of heart muscle are substantiated by the experimental work of Gaskell and others, which shows that muscles of poikilothermous animals, when cut into strips, are still possessed with the power of rhythmical contraction. It may be that these strips of muscle contain nerve cells or cells and fibres, but the results surely show a tendency to the so-called inherent property of rhythmical contraction which all heart muscle possesses.

6. It may be shown that the heart of an embryo chick begins to beat within from twenty-four to thirty-six hours after incubation is started. It may further be shown that there are no nerves associated in any way with the heart at this time, and so from these facts it is most positive that the musculature (mesodermic contractile cells which function as heart muscle) only can be responsible for these movements. At this stage of development there could be no possible nerve connection with the heart, as the neural tube, the forerunner of the cord, is only in the process of development, and there are no projections from it which could possibly be associated with the heart, the two structures being developed entirely separate—the heart originating from mesoderm and the neural tube coming from ectoderm.

**Summary of Causes of Heart Beat.**—Since there is so much theory and so little information in the above, we may say that from the developmental argument and considering the rest as secondary, it seems logical to conclude that the first and probably

the continued chief cause of heart beat is that inherent property of the mesodermic cells which renders them highly contractile, and that this property is also, to some extent at least, responsible for the automaticity and rhythmical activity of heart muscle.

Developmentally the nerve supply comes as a secondary structure, and probably serves to associate the functional activities of the heart with the demands of other parts of the body. The chief functions of the cardiac nerves would seem to be that of association and adaptation of the heart functions to the demands of the body as a whole. Physiologists as a rule, we believe, are too apt to place too great functional value on some particular structure, forgetting that it is only a part of the entire body machine. It is highly essential that the functions of the heart must depend for their regulation upon some mechanism which will associate these functions and regulate them to the demands of the body as a whole, and this seems to be the chief purpose of the cardiac nerves.

**Tone of Heart Muscle.**—Another function of the nerves to heart muscle is that of giving tone to the muscle fibres. As will be shown in the chapter on muscle physiology, the power of muscle fibres to contract depends largely upon the low degree of stimulus which is constantly being sent to the muscle fibres by way of the nerves which supply them. So long as the nerve supply is normally active the muscle fibres exist in a state of partial contraction, which makes them ready to receive and respond to a stronger stimulus. This property of muscle tone of cardiac muscle is therefore due to the nerve supply.

## CHAPTER V.

### NERVE SUPPLY TO THE HEART.

As has been given, the chief cause of the heart beat is some inherent power of the muscles of the heart to contract rhythmically, but it cannot be denied that certain nerves have a very important function to perform in the regulation of the force and rate of the heart beat. The circulation of blood is also controlled by those nerve fibres which supply the blood vessels and regulate the quantity of blood supplied to various structures, by causing variations in the size of the lumina of the supplying arteries.

**The Cardiac Nerves.**—The heart is supplied by two sets of efferent nerve fibers which arise primarily from the central nervous system. These sets of fibers arise from different parts of the central system. Their origin and development are different, and, as may be expected, the functions in the regulation of the action of the heart are also different. They act antagonistically, and in this way perform a regulatory function when acting together.

**The Vagi.**—The pneumogastrics or tenth cranial nerves, commonly known as the vagi, supply the heart with fibres which are inhibitory in function, and are therefore generally known as the cardio-inhibitors as opposed to the other nerve supply, which is accelerator in action.

**The Branches of the Vagus.**—Superior cardiac, which supply the heart, are given off from the vagus above the superior laryngeal, and the inferior cardiac branches are given off from the thoracic part of the nerve. It is thought that the inhibitory fibers arise chiefly from the inferior branches. These fibers, superior and inferior, unite with the branches of the spinal autonomic system (sympathetics) to form the common cardiac plexuses which lie on the arch of the aorta. The nerve fibers that supply

the heart directly extend from these plexuses and consist of both accelerator and inhibitor fibres. Some fibres may extend directly to or into the heart muscle, where they terminate about certain intrinsic ganglion cells and have other (post ganglionic) fibers distributed from this point to other parts of the heart.

**Evidence of Inhibitory Action of the Vagus.**—This function of the pneumogastric nerves may be demonstrated directly on animals by sectioning the vagus nerve of a living animal while a blood pressure or heart tracing is being made on a kymograph. Upon section of one vagus the heart rate will materially increase (there may be a few seconds of inhibition due to the stimulus to the nerve by handling and cutting), and will usually remain increased for some time. The explanation is that the vagus nerves normally send a certain amount of stimulus to the heart which tends to retard its function, and the cutting of one vagus stops one-half of this retarding influence. Since the spinal autonomies are functioning in exactly the opposite way, i. e., tending to increase or accelerate the heart beat, this regulatory influence is now acting out of proportion and the heart is receiving an excess of accelerator nerve stimulus in proportion to the inhibiting nerve stimulus. The rate is therefore increased.

Further experimental evidence may be had by cutting the other vagus, when another marked increase will be noted, and the explanation is the same as given for the causes of the changes occurring from the cutting of the first nerve.

If after the section of one or both vagi an artificial stimulus is applied to the peripheral end (the end leading toward the heart) of the nerve or nerves, the rate is quickly reduced and held so, as long as the stimulation is maintained. The amount of cardiac depression resulting from vagal stimulation varies directly with the strength of the stimulus. That is, if a light stimulus is applied and the amount of cardiac depression recorded, the application of a stronger stimulus will be followed by a greater depression of the heart's function.

If a very strong stimulus, such as an electrical stimulus from an induction coil be quickly applied, the heart may and usually

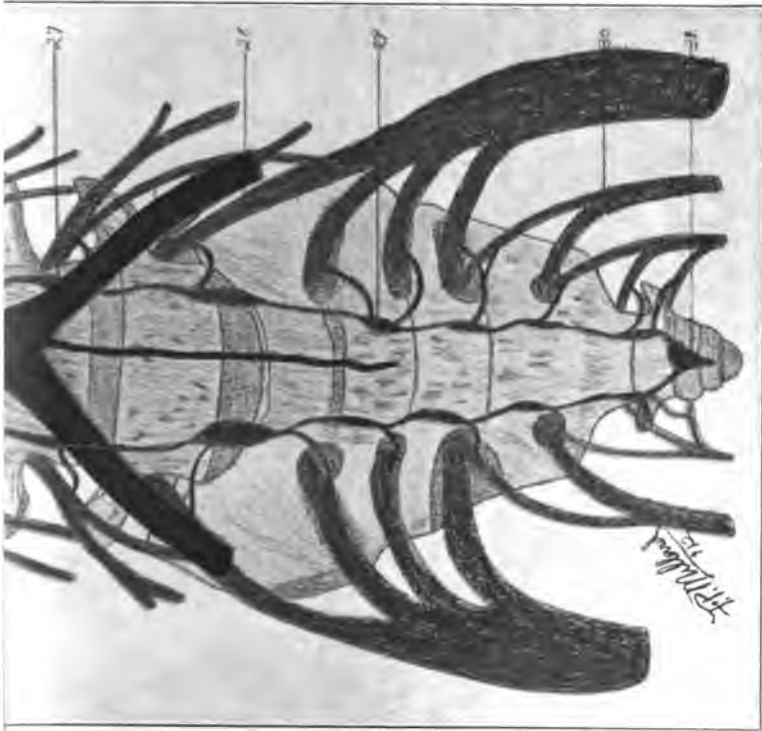

PLATE II.—PNEUMOGASTRIC CONNECTIONS. 1, Medulla; 2, ganglion of trunk of the pneumogastric; 3, superior laryngeal branch; 4, superior cervical ganglion; 5, second cervical nerve; 6, left pneumogastric; 7, middle cervical ganglion; 8, superior cervical cardiac ganglion; 9, inferior cervical ganglion; 10, pneumogastric; 11, first thoracic; 12, left common carotid; 13, left subclavian; 14, right recurrent laryngeal nerve; 15, inferior cervical cardiac branch; 16, aorta; 17, cardiac branch from left recurrent laryngeal nerve; 18, pulmonary plexus; 19, celiac plexus; 20, gastric branches of vagus; 21, hepatic plexus; 22, splenic plexus; 23, renal plexus; 24, termination of spinal cord (filum terminale); 25, second lumbar nerve; 26, abdominal aorta; 27, left common iliac; 28, lumbo-sacral cord; 29, sacral ganglion; 30, small sciatic; 31, ganglion impar.





does stop entirely, but recovery usually results. The amount of cardiac depression resulting from vagal stimulation varies with different species, and also with various individuals of the same species. This inhibitory influence of the vagus on the heart was first demonstrated by the Weber brothers in 1845, which was the beginning of the many discoveries of the functions of the cardiac nerves.

**Nature of Effects of the Inhibition.**—When the peripheral end of the vagus is stimulated it may be shown that the heart beat is decreased in both rate and amplitude. The quantity of blood forced into the arteries is therefore decreased, and this, in addition to the slowing of the rate of heart beat, results in a decrease in arterial blood pressure.

**The Inhibitory Center.**—The nucleus ambiguus, the motor nucleus of the tenth nerve, contains certain cells to which the nucleus of cardio-inhibition is attributed, and this group of cells is commonly considered to be the center for reflex or autonomic regulation of the inhibitory influence upon the heart caused by certain fibers of the vagus nerve. The exact part of the vagal center which contains these inhibitory cells has never been definitely located, but its existence has been demonstrated by the study of reflex effects. Like other centers, this center is bi-lateral—one on each side, each having to do with fibers for its own nerve. It is possible that these two centers are connected by commissural cells, as the stimulation of one center seems to influence both. If, for example, one vagus nerve be sectioned and a stimulus applied to its central end (the end leading into the medulla) a decrease in the rate of heart beat sometimes follows. When this occurs it is possible to explain such action by assuming that the stimulus passed into the center of the stimulated side crossed and passed down by way of the other vagus. This is the explanation generally offered, but the author, after having tested this on more than one hundred animals, found that when the central end of one cut vagus was stimulated, the result was almost invariably an increase instead of a decrease in heart rate and blood pressure. An explanation of this will be offered later. It seems more reasonable

to assume, as some authorities now do, that the centers of the vagi send out two groups of fibers—one group, the larger one, passing to the vagal trunk of the same side and a few passing to the vagal trunk of the opposite side. These crossing fibres are comparatively few in numbers compared with the direct fibers, but this could easily explain how, in the few instances, the stimulation of one vagal center could influence the opposite nerve.

**Reflex Action of the Cardio-Inhibitors.**—It was shown by Goltz that the inhibiting functions of the vagi could be influenced by stimulation of certain afferent or sensory nerve paths. He showed, for example, that tapping the abdomen of a frog would inhibit the heart and often completely stop its beating. This author further found that such results were not obtained in frogs in which the vagi had been sectioned.

As mentioned above, it has been found that in some mammals the stimulation of the central end of one cut vagus will be followed by cardio-inhibition, although this does not seem to be the common rule. It is probable that the vagus contains afferent (ingoing) fibres from the abdominal and thoracic viscera, the stimulation of which may result in a reflex cardio-inhibition by exciting the cardio-inhibitory center to greater activity, which causes a greater number of efferent (outgoing) stimuli to be sent to the heart muscle by way of the cardio-inhibitory fibers.

This is the explanation of how a sudden blow on the abdominal wall, over-distension of the stomach from gas or a large meal, acute gastric pains, etc., may sometimes cause variation in heart action.

**Cause of Inhibition.**—Many theories have arisen for the explanation of the way in which the inhibition is effected. It has been shown that the inhibitory influence of the vagus is not caused by any special properties of the fibres or the nature of the impulses, but is probably due to the particular part of the heart in which these fibres terminate. It has been shown by Erlanger that if another of the cranial nerves (fifth cranial) be sutured to the peripheral end of the cut vagus and sufficient time allowed for regeneration, a stimulus applied to this regenerated fifth nerve will

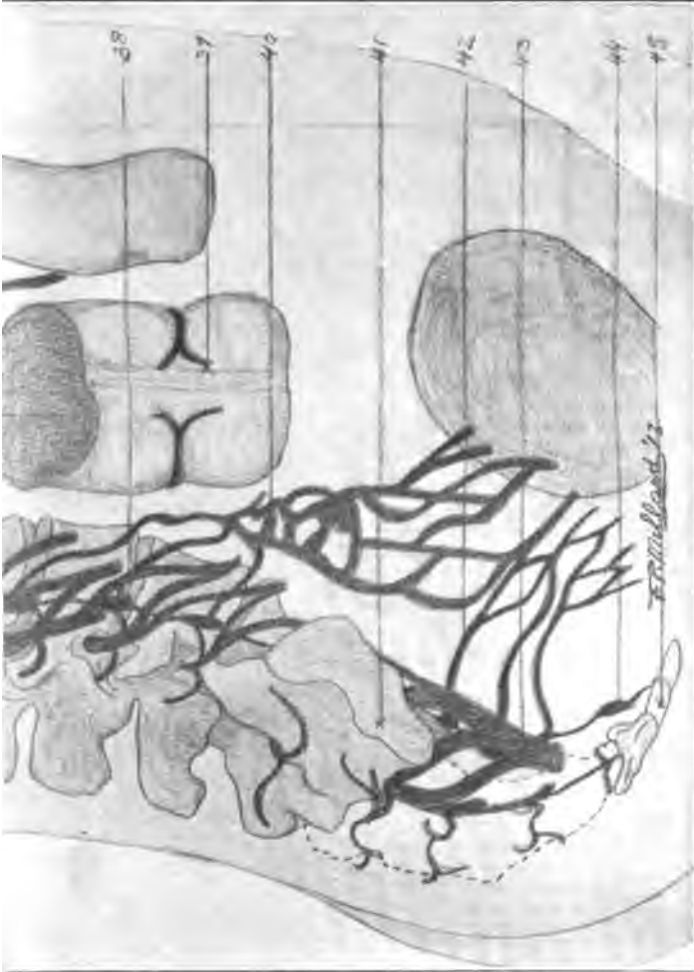

PLATE III. —1. Optic nerve; 2. ciliary ganglion; 3. ophthalmic division of the trigeminus; 4. Gasserian ganglion; 5. superior maxillary division; 6. sphenopalatine ganglion; 7. chorda tympani branch of the facial; 8. lingual branch of the inferior maxillary division; 9. glossopharyngeal; 10. hypoglossal; 11. pneumogastric; 12. submaxillary ganglion; 13. superior cervical ganglion; 14. superior laryngeal nerve; 15. superior cardiac nerve; 16. fifth cervical nerve; 17. superior cervical cardiac branch of the vagus; 18. middle cervical ganglion; 19. middle cervical cardiac sympathetic branch; 20. inferior cervical ganglion; 21. inferior cervical cardiac branch of the sympathetic; 22. first thoracic; 23. second thoracic ganglion with both gray and white rami; 24. anterior root of the third thoracic; 25. posterior root of the fourth thoracic; 26. heart; 27. upper branch of the great splanchnic; 28. a-splanchnic; 29. spinal cord showing anterior and posterior nerve roots (vertebrae from first dorsal to third lumbar have been removed to show the region from which the great outflow of vaso-constrictor fibers emanate); 30. great splanchnic nerve containing pre-ganglionic fibers of cerebro-spinal origin; 31. semilunar ganglion; 32. small splanchnic nerve; 33. least splanchnic nerve connected with 34. renal plexus; 35. termination of spinal cord; 36. small intestine; 37. second lumbar nerve with white and gray rami; 38. lumbar ganglion; 39. colon; 40. hypogastric plexus; 41. sacrum, lower part cut away to show nervi erigentes (second to fourth); 42. second sacral ganglionic branch; 43. great sciatic; 44. ganglion impar; 45. coccyx.



be followed by cardio-inhibition as in case of the vagus. Gaskell, who has done some interesting work on this subject, believes that the cause of inhibition lies in the kind of metabolic changes effected in the heart, which are opposite from those occurring during contraction. He believes that during contraction the chemical changes are catabolic, resulting in the liberation of the stored-up (potential) energy, thus giving energy for muscle work (see muscle physiology), and that during inhibition the opposite metabolic reaction occurs, which is anabolic or synthetic in nature, resulting in giving to the heart a greater power of energy for contraction. It must be admitted that the theory seems logical and that this author has developed not a little experimental evidence in its favor. The principles of the theory will be better understood by a careful reading of the cause of muscle contraction and the sources of muscle energy. (See index.)

**Drugs and Cardio-Inhibition.**—Certain drugs when injected subcutaneously or intravenously produce changes in the rate and force of heart beat. Atropin causes a quickening of the heart similar to that caused by the cutting of the vagi, and since stimulation of the peripheral end of the vagus fails to produce inhibition after the administration of atropin, it is assumed that the atropin paralyzes the post-ganglionic fibres of the heart muscle (the endings) of the vagus. Curare produces similar effects on smooth muscle, the drug affecting the motor end plates, as will be given later. Just the opposite effect is obtained when muscarin or pilocarpin is used instead of atropin. If an injection is made of muscarin or pilocarpin the heart rate is decreased, and if the dose is sufficiently large or if the injections be continued, complete cessation of the heartbeat results. This effect can be relieved or prevented if the injection is followed by an injection of atropin. It is therefore assumed that muscarin and pilocarpin stimulate the post-ganglionic fibres of the vagus. Some authorities believe these drugs produce their effects by some specific action on the heart muscle. The reader may find additional information on this subject in texts on pharmacology. We can only say, regard-

ing the action of these drugs, that no positive information can be found on the subject.

**The Cardio-Accelerators.**—The nerve fibres supplying the heart from the spinal autonomies—the cardio-accelerators—are efferent or motor nerves originating from the so-called sympathetic system. There is some variation in the course of these fibres and their method of distribution, but for the most part their course and functions are about the same in all mammals.

**Origin and Distribution.**—These fibres originate from cells which lie in the anterior horn of the gray matter of the spinal cord of the second, third and fourth segments of the thoracic area of the spinal cord. Their fibres pass out with the anterior roots of the spinal nerves of these segments. It is claimed by some authorities that they may be found in the anterior spinal nerves from the first to the fifth thoracic segments, inclusive. These fibres (white rami) pass to the first thoracic (stellate) ganglion and from here by way of the annulus of Vieussens to the inferior cervical ganglion. See plates II and III. Some of the fibres pass from here to the cardiac plexus and from this plexus to the heart. These fibres constitute a part of the cardio-accelerators, which continue with some of the cardio-inhibitory fibres of the vagus to the plexus.

The pre-ganglionic portion of the axon which extends from the cell in the cord may terminate in the stellate ganglion or the inferior cervical ganglion. These axones (processes extending from the cell body) terminate about another cell body, and this second cell with its axon which extends onward, constitutes the post-ganglionic fibre.

**Function of the Cardio-Accelerators.**—As evidence of the accelerator function of these fibres, stimulatory experiments may be tried. If artificial stimulus be applied to the stellate ganglion, the inferior cervical ganglion or the peripheral ends of the sectioned nerves, a marked increase in the heart beat, both rate and amplitude, results. If these fibres are cut a marked slowing of the heart follows. The explanation is that the cutting prevents the supply of the normal amount of stimulus which tends to accelerate the heart, and the inhibitory influence of the

PLATE IV.—This chart shows the heart and its chief vessels with some of the spinal nerves: 1, Oblongata; 2, superior cervical ganglion; 3, vertebral artery; 4, middle cervical ganglion; 5, inferior cervical ganglion; 6, brachial plexus; 7, arch of aorta; 8, pulmonary arteries; 9, pulmonary veins; 10, heart; 11, inferior vena cava; X, aorta; 12, spinal cord; 13, abdominal aorta; 14, end of spinal cord; 15, lumbar nerves; 16, iliac vessels; 17, cauda equina; 18, femoral vessels; 19, great sciatic nerve.

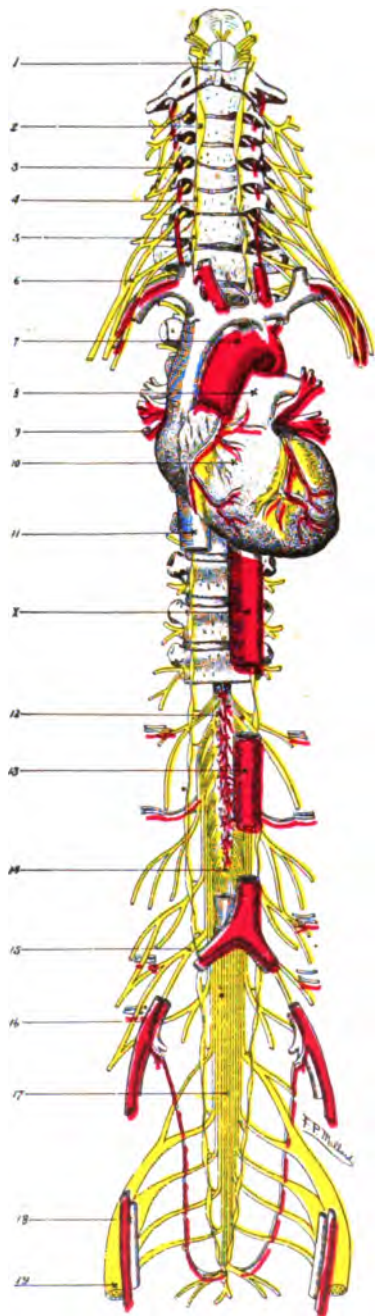





fibres of the vagus cause the depression. This is further confirmed by the increase in the heart rate by stimulation of the peripheral ends of these fibres after the depression has resulted from the cutting.

Whether these special fibres have other functions on the heart is not positively known. It has been suggested that they may have trophic functions to the heart muscle, but it seems most probable that they only tend to liberate the energy stored up, and in this way cause the increased functional activity of heart muscle.

**Nature of the Acceleration.**—Stimulation of these fibres or their cell ganglia produces a very marked increase in the heart beat. The rate is often increased from fifty to seventy per cent, and remains so for some time after the stimulus is removed. The blood pressure in the arteries is not always increased by such stimuli, as the rate may be increased while the amplitude of contraction remains the same or is decreased, and there is therefore no more blood expelled from the heart than normally, but with the increased rate there is usually an increase in the quantity of blood thrown out at each contraction, and the blood pressure is therefore nearly always increased in proportion to the rate of the heart beat. Some authors hold that there are two types of acceleration fibres: 1. Those that only increase the rate of the heart beat, the accelerators proper; and 2. Those that are concerned with the increase in the amplitude or force of the beat—the augmentors—which cause the heart to expel a greater amount of blood at each beat. It is further claimed by some that the course of these different fibres is known, and that the accelerators come from the right plexuses while the augmentors arise from the left plexuses.

**The Cardio-Accelerator Centers.**—It is thought that there is a center in the medulla from which fibres are sent downward to the cell bodies lying in the upper dorsal segments of the spinal cord. The fact that stimulation of the upper cervical region of the cord produces acceleration of the heart is generally considered to be evidence of this. It has been conclusively shown (Deason and Robb) that stimulation of the central ends of nerves which

arise from the medulla or cervical cord, such as the vagi or phrenics, also produces cardio-acceleration, and this might also be considered as evidence of the existence of such a center, but this effect can be obtained from the stimulation of the central end of almost any sensory or mixed nerve, and it would therefore seem that this evidence is not entirely conclusive. If such a primary center does exist in the medulla there is surely another center or centers (they may be considered reflex transfer stations) in the upper dorsal, and possibly the lower cervical segments of the cord, which also take some part in the regulation of these functions.

The upper tracing in this figure represents the respiration while the lower tracing represents the heart beat and blood pressure. The line beneath is the base line, the white areas of which represent the time during which stimulation was being applied. It will be observed that the stimulation affected both respiration and blood pressure. The second normal represents the period of rest after the first stimulation, and it will be seen that while neither the blood pressure nor the respiration returned to normal there was a second very marked increase when the second stimulus was applied.

**Reflex and Tonic Activities.**—The experimental evidence, the effects obtained from afferent stimulation, leads us to conclude that the activity of these centers is maintained and influenced



FIG. 2.

largely by afferent (sensory) stimuli coming in from the periphery. It has many times been shown that the stimulation of sensory nerves leading into the cord causes a marked increase in the activity of these accelerator fibres.

It may also be shown that the accelerator fibres are normally in a state of tonic activity, by cutting one or both of the groups of fibres leading to the heart. If these fibres are sectioned the heart rate is materially reduced by the activity of the vagi. This shows that a certain amount of stimulus is constantly passing to the heart by way of these fibres which is accelerator in action.

**The Functional Balance.**—The value of such a physiological balance of function which is constantly maintained by the antagonistic action of the inhibitors and accelerators can readily be seen when it is understood that, in order to obtain necessary variations of functional activity of an organ by reflex effects, such a mechanism must exist. When a structure is so regulated in its activities and a normal amount of tone of the structure exists from the effects of both of these nerve supplies, it is only necessary that one of them have its action increased or the other inhibited to cause the change needed to adapt the animal to sudden demand of function.

This is, therefore, a mechanism by means of which the animal may reflexly adapt itself to certain immediate environmental demands of function. Under certain conditions, such as in the case of animals in combat for example, there is a demand for an increased blood pressure, etc., which is effected reflexly by stimulation of the centers or cell bodies of the accelerators in the central nervous system.

It is also known that the mental state of the individual often influences this heart-regulating mechanism. Certain emotions are known to cause heart variations, which may be explained by assuming the existence of a connection of these heart-regulating centers with certain brain centers.

## CHAPTER VI.

### NERVE SUPPLY TO THE BLOOD VESSELS.

**The Vasomotor Nerves.**—Claud Bernard in 1857 found that the spinal autonomic fibers distributed from the lateral chain contained fibers which regulated the size of the blood vessels by causing variations in the size of their lumina, and in this way varying the quantity and pressure of blood. The elastic property of the arteries had been thought to determine the adaptability of the blood-supplying vessels up to this time.

**Evidence of Vasomotor Fibers.**—It may be shown by sectioning the spinal autonomies (sympathetics) in the neck of the rabbit, that the vessels of the ear of the same side become much dilated. This was Bernard's classical experiment which first demonstrated the presence of such fibers. It may be further shown that if the peripheral end of this cut nerve be stimulated, the vessels of the ear constrict and the ear becomes blanched from the lack of blood. This may be shown in both ears at the same time by stimulating simultaneously the peripheral ends of the autonomies on both sides, or if one side be cut and the other stimulated, the ear on the cut side will become reddened while the other will be blanched at the same time.

**Kinds of Vasomotors.**—It has been found that the stimulation of certain nerve trunks or fibers, or in some instances the ganglia or segments of the spinal cord, causes a constriction of the small arteries supplying certain structures. Because of this effect, these fibers are termed vaso-constrictors. It has also been found (first by Bernard) that the stimulation of certain other nerves causes just the opposite effect or dilation of the vessels, and these fibers are therefore known as the vaso-dilators.

These two sets of fibers therefore regulate the size of the small arteries in such a way as to determine the supply of blood to

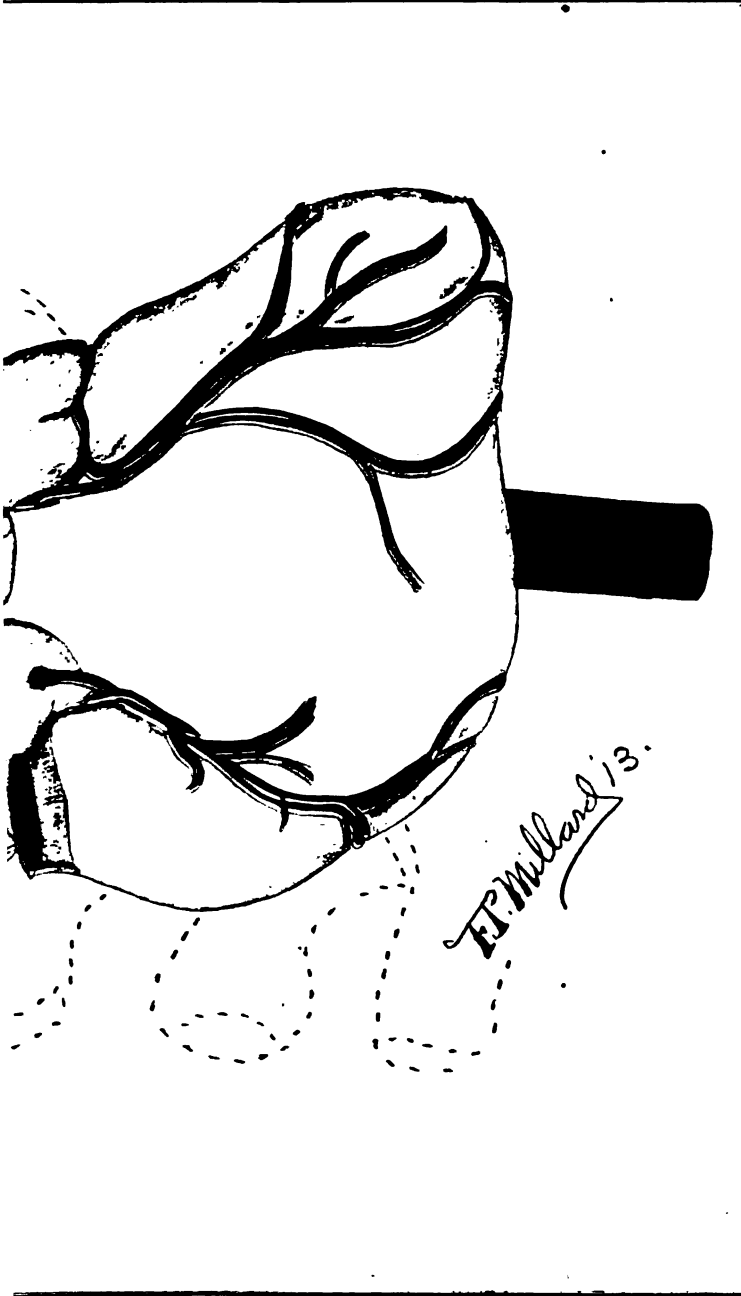

PLATE V.—NERVE SUPPLY TO THE HEART. 1, right pneumogastric; 2, superior cervical ganglion; 3, superior cervical cardiac ganglion; 4, middle cervical cardiac branch of the pneumogastric; 5, superior cervical cardiac branch of the sympathetic; 6, middle cervical cardiac branch of the sympathetic; 7, inferior cervical cardiac branch of the sympathetic; 8, inferior cervical cardiac branch of the sympathetic; 9, inferior cervical cardiac branch of the vagus; 10, recurrent laryngeal passing back of the subclavian artery; 11, cardiac branch from recurrent laryngeal; 12, thoracic cardiac branch of the right vagus; 13, deep cardiac plexus; 14, right bronchus; 15, left pneumogastric; 16, left superior cervical ganglion; 17, left superior cervical cardiac branch of the sympathetic ganglion to superficial cardiac plexus; 18, middle cervical cardiac branch of the vagus; 19, superior cervical cardiac branch of the sympathetic; 20, middle cervical cardiac branch of the sympathetic; 21, inferior cervical cardiac branch of the sympathetic; 22, inferior cervical cardiac branch of the sympathetic; 23, inferior cervical cardiac branch of the pneumogastric to superficial cardiac plexus; 24, left recurrent laryngeal; 25, superficial cardiac plexus.



certain structures. The salivary glands furnish a good example of such a regulation of function. The spinal autonomic fibers which are supplied to these glands by way of their arteries are vaso-constrictors, and stimulation of these fibers causes a decreased supply of blood to the glands and a temporary increase in the blood pressure of the vessels of the glands. Other fibres which are distributed to the glands by way of certain cranial nerves are vaso-dilators, and it may be shown that the stimulation of these

fibers causes a dilation of the blood vessels of the glands and a decrease of the pressure within the vessels. The physiological value of such a mechanism will be found given in the discussion of the function of these glands.

**Methods of Study of Vasomotor Effects.**—As explained above under "Evidence of Vasomotor Fibers," the existence of such nerve fibers and their functions may be studied:

1. By observing the structure while its nerve supply is being stimulated. If the structure receives vasomotor fibers, it may be seen to blanch while the nerves are being stimulated, and after the stimulus is removed it may be seen to become congested.



FIG. 3.—Hand-form plethysmograph. A, base; b, hand grip; c, hand; d, diaphragm; e, tube to recording apparatus.

2. Various instruments have been devised for determining the blood supply to a part, some of which are of value. The plethysmograph, one of the most commonly used, consists of a tube into which the finger or arm may be placed. The space about the arm is fitted tightly with a wide rubber band in such a way as to make the space about the arm water-tight. A small tube leads from the space about the arm to some kind of recording apparatus. The space about the arm is filled with water at about body temperature, and the arm is held firmly to prevent movement. By the application of cold or hot packs on the arm out-



side of the plethysmograph it may be shown that variations in the volume of the water contained about the arm in the plethysmograph can be effected. Any increase means vaso-dilation of the vessels of the arm, which causes an increase in the volume of the arm. Any decrease of the volume of water within the plethysmograph means vaso-constriction. Plethysmographs have been devised for the study of blood-pressure changes in various glands, such as the kidney, spleen, etc. They are made to fit the structure as closely as possible, and have a rubber sack which is held in a metallic case. The sack contains some kind of fluid that the structure may displace during expansion.

3. Vasomotor effects may also be determined by measuring the quantity of blood thrown off by the veins. If this quantity is increased by stimulation of the nerve supply to the structure it is known that vaso-dilation has resulted from the stimulation. If the quantity of blood is decreased, it is known that the opposite effect or vaso-constriction has occurred.

**Vasomotor Centers.**—It has been shown that if the spinal cord be cut in the cervical or upper dorsal region, the vaso-constrictor fibers lose their tone or power to maintain the normal amount of tension of the smooth muscles of the arteries which they supply, and vaso-dilation is the result. It is therefore supposed that there is some center or centers in the brain, probably in the medulla, which influence this vaso-constriction function. It is supposed that fiber paths (axones) from the cells in these "higher centers" extend downward in the spinal cord and termi-

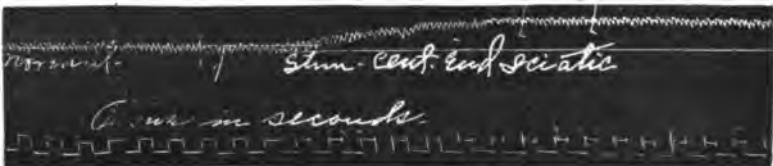

FIG. 4.—This tracing shows the result of electrical stimulation applied to the central end of the sciatic nerve in the normal animal. It will be noted that a marked increase in the blood pressure resulted from the stimulation. If, after such tests have been made, a lesion be placed in the mid-dorsal region of the animal and the stimulation repeated, no increase of blood pressure results, which fact shows that the lesion has in some way interfered with the normal functions of the reflex mechanism causing abnormal results from the stimulation.

nate about other cells or groups of cells at various (probably all) levels of the cord, which groups of cells may be considered as the secondary or cord centers. The cells of the cord lie in the anterolateral portion of the gray matter, and send their axones out with the anterior spinal nerve root. This axon is the pre-ganglionic portion which terminates in some other ganglion, from which a post-ganglionic fibre continues to the structure supplied. It is generally considered that there is a similar center for the regulation of vaso-dilation effects, since these functions are controlled in a similar way to the vaso-constrictors. It is further supposed by some that a primary center for the regulation of this function is located somewhere in the brain, but the positive evidence is lacking. It has been established that there are "centers" in the cord, i. e., certain areas, the stimulation of which will cause vaso-dilation in certain structures. This subject of the "Spinal Cord Centers" will be discussed elsewhere.

**Vasomotor Reflexes.**—Since it has been shown that certain more or less definite areas exist which may be called centers, from which axones extend which control these functions, it may be assumed with good reason that these so-called centers may be and are influenced by sensory or afferent impulses, and in this way their functions may be affected. A certain amount of normal afferent or incoming stimulus probably keeps these cells active,



FIG. 5.—This tracing shows the results of stimulation of the central end of the sciatic nerve on respiration and blood pressure. The upper line represents the respiratory tracing and the lower line represents the blood-pressure effects. The time rate is represented between the two drawings. The white parts in the base line show the time and length of the stimulation. It will be noted that a marked increase in respiration and blood pressure due to an increased functional activity of the centers results from the stimulation of the central end of spinal nerves. The normal stimulation, which comes in from the sensory surfaces by way of these nerves, is responsible for the maintenance of normal tone of these centers, thus regulating the functions of the structures supplied by the efferent autonomic nerves.

and in this way normal tone of the vaso-motors is effected, which keeps the smooth muscle supplied by them in a state of constant partial contraction.

There is also good experimental evidence to show that these afferent fibres are of different kinds. Those the stimulation of which causes an increased activity of the vaso-constrictor centers and therefore a vaso-constriction, are known as the "pressor fibers," and those which diminish the tone of the vaso-constrictor centers and by this means cause a vaso-dilation, are known as the "depressor fibers." These effects are, of course, all effected reflexly. It seems reasonable to assume that the blood pressure in different structures and in the entire system may be regulated by such a mechanism, and that these fibers—the afferent and efferent mechanism—form an important physiological association of internal functions to external environmental changes.

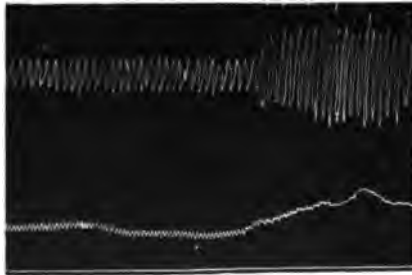
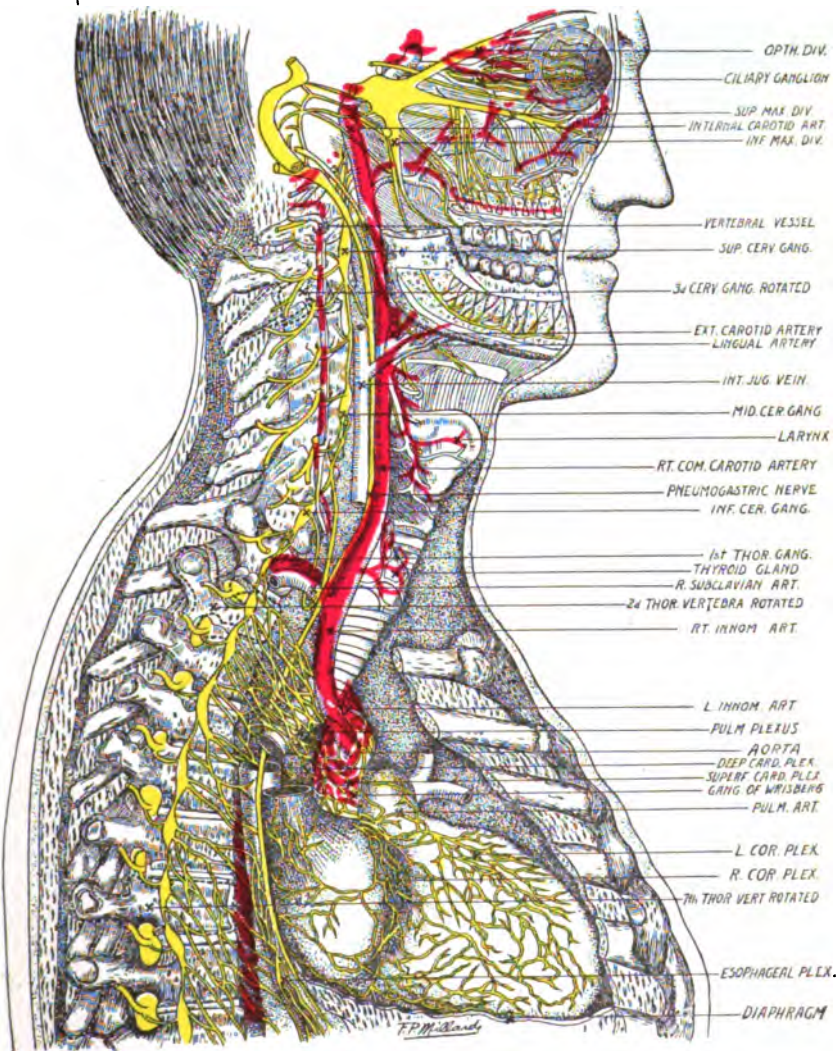

FIG. 6.—This figure shows the result of the stimulation of the central end of a spinal or cranial nerve. The reflex effect on the center results in an increased activity of these centers, which is followed by an increase in respiration, an increase in blood pressure due to reflex vaso-constriction, and there is usually an increase in the rate of the heart beat. The upper line in this figure shows the increase in respiration and the lower line shows the increase in blood pressure.

**Course and Distribution of the Vasomotors.**—Since the origin, course, and distribution of the vaso-dilator fibers is different from that of the constrictors, it becomes necessary to discuss them separately.

**The Vaso-Constrictors.**—The fibres constituting this system all belong to the spinal autonemics. The cell bodies which give rise to these fibers lie in the antero-lateral part of the



**PLATE VI.**—The various nerves forming plexuses and controlling the functions of the bronchial tubes are shown in this cut, also their communication with the cerebro-spinal nerves through the rami. The anterior and posterior pulmonary plexuses are shown in front of and back of the bronchial tubes. These are formed almost entirely from the sympathetic and pneumogastric nerves (the pneumo branch of the pneumogastric). The spinal nerves are shown, also the small fibers connecting them with the sympathetic chain. The second thoracic vertebra is shown rotated, in dotted lines. Notice the close connection between the nerves leading to the bronchial tubes and the cardiac, leading to the heart. Rapid breathing and heart action are usually associated with coughs. (See explanation of how spinal lesions produce perverted physiological effects in Part II.)



gray matter of the spinal cord, from the second thoracic to the third lumbar segments, inclusive. Fibers (axones) pass from these cells to the lateral chain ganglia or to peripheral plexuses as pre-ganglionic fibers. The post-ganglionic fibers pass from the point of termination of the pre-ganglionic fiber to the muscles of arteries supplied.



FIG. 7.—The upper line in this tracing shows the result of stimulation of the central end of the sciatic after an artificial bony lesion had been produced in the mid-dorsal region. It will be seen by referring to Figs. 4 and 5 that this is just the opposite from the normal reaction which should have occurred. The lower tracing shows the normal changes before lesion.

Vaso-constrictor fibers are to be found in nearly all nerve trunks, both spinal and autonomic. Those nerve trunks—the splanchnics, which supply the abdominal and pelvic viscera, and the spinal nerves which supply the skin—are especially rich in vaso-constrictor fibers. The spinal nerve trunks which carry vaso-constrictors to skin surfaces, arteries of the muscles, etc., also carry other autonomic fibers, such as fibers to the sweat glands (secretory); pilomotor fibers to the muscles of the skin, and possibly others. In the spinal autonomies, which supply fibers to the abdominal and thoracic viscera, there are many other fibers carried along in the same nerve trunk with the vaso-constrictors, such as accelerators to the heart; augmentors to the heart; pupillo-dilators; visceromotors and probably some secretory fibers. As may be seen from Plates II and III, the axones pass out by the anterior spinal root to some of the ganglia of the lateral chain. These are the white rami communicantes. After having reached the lateral chain, these fibres 1. may terminate about a cell body of the first ganglion reached, or 2. they may

pass up or down the lateral chain to terminate in some other ganglion; or 3. they may pass beyond the lateral chain to some peripheral ganglion; 4. the post-ganglionic fibers which are supplied to skin and the arteries of muscles, etc., originate from cells in the lateral chain, pass back and are distributed with the spinal nerves. These are the gray rami communicantes; 5. there are other fibers which pass back and supply the arteries of the meninges of the cord.



FIG. 8.—This tracing shows the result of osteopathic stimulation applied to the upper dorsal regions of the spine in the dog. It will be noted that a marked increase in blood pressure occurred during the time of stimulation, which immediately dropped as soon as the stimulation was discontinued.

**Structures Supplied by Vaso-Constrictors.**—There are only three important structures of the body—the brain, the lungs and the heart—to which vasomotor fibers of one kind or the other have not been demonstrated. Whether or not these organs receive vasomotor nerve fibers is yet a question which future research work may decide.

It has been shown by Martin that the stimulation of the vagus causes dilation of the arteries on the surface of the heart. There is other experimental evidence in favor of the existence of vasomotor fibers to the heart, both constrictors and dilators, but nothing has been conclusively proven.

**Blood Supply to the Brain.**—Since the brain, a soft structure, is contained within the very rigid walls of the cranium, expansions and contractions caused by extreme variations cannot be compensated for by extension, as in most other body structures. This condition would seem to demand a different circulatory mechanism than that which exists in other organs. The two vertebral arteries and the two internal carotids, which form the circle of Willis, constitute the arterial supply to the brain. The

arrangement of the blood supply is such that the circulation to the brain would not be easily disturbed by an interference with one artery, but in some instances the occlusion or even a compression of these arteries is followed by physiological perversions. "In some animals, the dog, one can ligate both internal carotids and both vertebrales without causing unconsciousness or the death of the animal. In an animal under these conditions a collateral circulation must be brought into play through the anastomoses of the spinal arteries. In man, on the contrary, it is stated that ligation of both carotids is dangerous or fatal." (Howell.)

The author has found that ligation or even temporary compression of the carotid arteries in cats results in marked variations in physiological functions of the brain. If, for example, after the two carotids are ligated the ether be discontinued, the animal will often not regain consciousness, or temporary compression of the carotids may be made to take the place of the anesthetic. This shows only the immediate effects of an obstructive interference with the blood supply to the brain. What the result would be of a long-standing or permanent partial interference would be has never been experimentally determined, but it is safe to say that no disturbance of such a nature could exist without resulting in some perversion of the functions of the brain. There is much good clinical evidence to show that bony lesions often produce such effects.

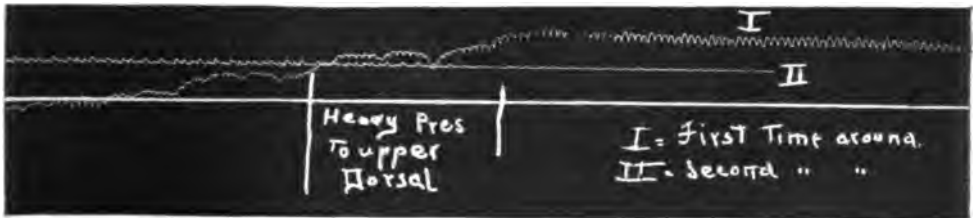

FIG. 9.—This tracing shows the result of heavy pressure stimulation applied to the upper dorsal region of the spine. It will be noted, as shown in No. 1 of the tracing, that a marked increase in blood pressure resulted, which remained three millimeters above the base line after the drum had made a complete revolution. This shows the permanence of the effects of the stimulation. By referring to Figs. 8 and 9 it will be seen that pressure and manipulation produce practically the same effects on blood-pressure changes.



The venous drainage of the brain is effected chiefly by way of the venous sinuses, which are spaces between the folds of dura mater or between the dura and the skull bones. These sinuses receive the cerebral veins and veins from the bones of the skull, pia mater, and dura mater. The greater part of the venous blood is drained into the internal jugular veins from the lateral sinuses, but some of it is drained into the ophthalmic veins and some into the venous plexuses of the spinal cord and its meninges. Since the cerebrospinal fluid, its formation and drainage has much to do with the regulation of intracranial pressure, the reader is referred to that subject.

Any increase in systemic blood pressure is followed by an increase in intracranial pressure and an increase in the actual amount of blood flowing through the brain. The physiological effects of this increased supply of blood and the increased blood pressure are not well known.

It is not known whether or not the arteries of the brain are supplied with vasomotor nerve fibers, but the general opinion of those research workers who have tried to determine this question is that these vessels have no such provision.

**Vaso-Constrictors to the Head and Neck.**—The vaso-constrictor nerve supply to various structures of the head, such as the skin, the mucous membranes of the mouth and eyes, and the glands of the mouth and neck, are derived from the cervical portion of the spinal autonomies. The pre-ganglionic fibers arise from the upper thoracic segments of the cord, pass upwards in the lateral chain, and terminate chiefly in the superior cervical ganglion. From here the post-ganglionic fibers are distributed to the various structures supplied by various paths, but they usually follow the arteries that supply the structures. In some cases it has been shown that both constrictor and dilator fibers follow the same course, which is the path of some cervical or cranial nerve.

**Vaso-Constrictors to the Upper Limbs.**—The fibers supplying the upper limbs originate from the mid and upper thoracic regions of the cord, and are distributed from the ganglia

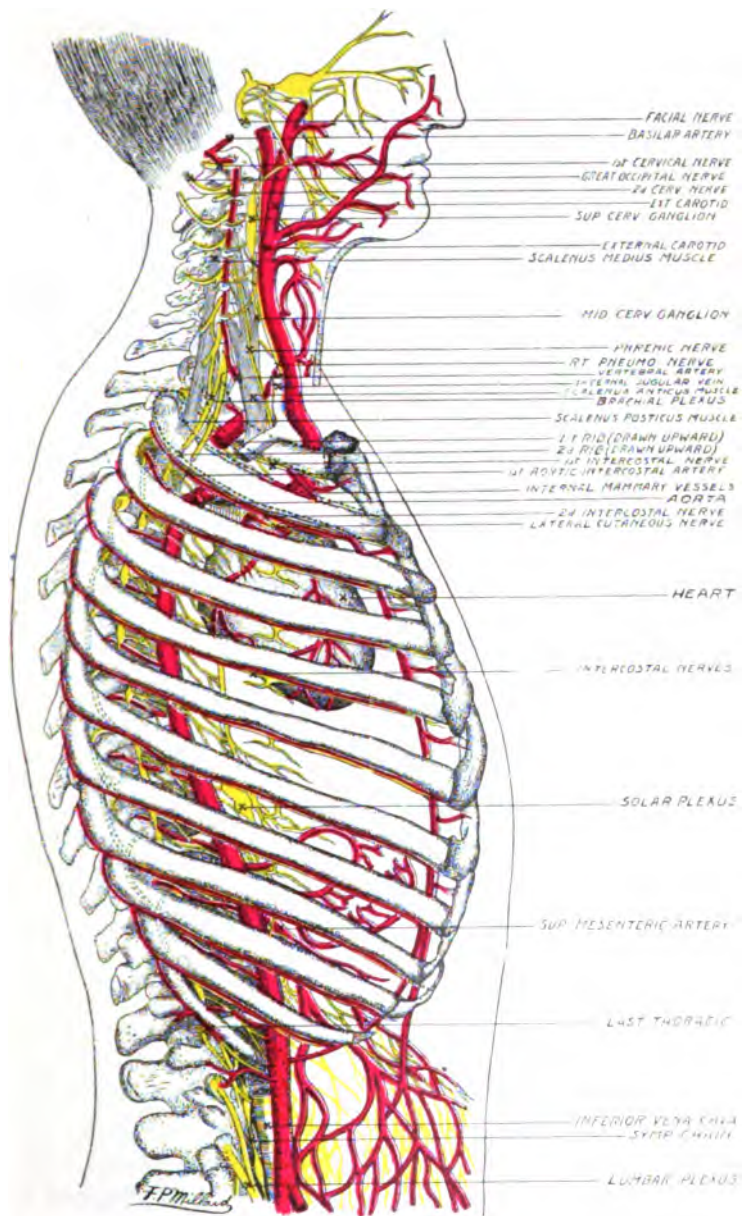

**PLATE VII.**—Showing heart, aorta, and some of its branches, including arteries to the neck and face, also the intercostal vessels. Notice that the vessels are surrounded by nerves from the sympathetic chain which control their size. By referring to plates II, III, and IV, the connections of these nerves with the spinal cord may be seen.



of the lateral chain by way of the spinal nerves to the skin, and probably to the muscles and joints.

The fibers supplying the skin of the trunk come from the thoracic portions of the lateral chain, and are supplied with spinal nerves to the various parts.

The fibers supplying the lower limbs originate from the lower thoracic and upper lumbar portions of the lateral chain, and are distributed with the spinal nerves as in case of the ones described above.

**Vaso-Constrictor Supply to the Abdominal Viscera.—**

These fibers are to be found in the splanchnic nerves, and are derived from the fifth to the twelfth thoracic segments of the cord, inclusively. Some may come from the first and second lumbar segments of the spinal cord. They supply the following structures: 1. The arteries of the mesentery from the œsophagus to the descending colon; 2. the pancreas; 3. the kidneys; 4. the spleen; 5. possibly the liver. The stomach receives its vaso-motor supply from the fifth to ninth thoracic segments of the cord. The fibers supplying the intestines originate from all of the spinal autonemics from the fifth thoracic to the second lumbar, inclusive. The liver receives its splanchnic (viscero-motor and possibly secretory and trophic) from the seventh, eighth, and ninth spinal segments, and there is some experimental evidence to show that it receives vaso-constrictor fibers from this source. Some authorities claim that the vaso-constrictors of the liver originate from the eleventh and twelfth thoracic segments. The pancreas receives its vaso-constrictor supply from about the same region as the liver. Since these structures, the liver and the pancreas, are developed from the alimentary tube, they may be expected to have the same common nerve supply, and they do. The vagus supplies these structures with secretory fibers (they have been demonstrated to the pancreas but not yet to the liver), probably trophic, and possibly vaso-dilator fibers.

The kidneys receive their vaso-constrictors from the eleventh and twelfth thoracic segments of the cord, and they may possibly get some fibers from the upper lumbar segments. From the

results of Series No. 16 (See Part II), it would seem that these fibers are also secretory. Some authors claim that vaso-dilator fibers to the kidneys may also be found in these nerves.

The vaso-constrictor fibers supplying the spleen originate from the sixth, seventh, and eighth thoracic segments of the spinal cord. These fibers (pre-ganglionic portions) originate from cell bodies lying in the antero-lateral part of the gray matter of the cord of the different segments named, and pass out by way of the anterior root to the lateral chain. Some of the axones of the pre-ganglionic fibers end immediately in the ganglia of the lateral chain. Some pass up or down one or more segments and terminate about cell bodies, and some are distributed beyond the lateral chain to the prevertebral plexuses. Other fibers (the post-ganglionic fibers) arise from the point of termination of the pre-ganglionic fibers, and are distributed to the vessels of the viscera supplied.

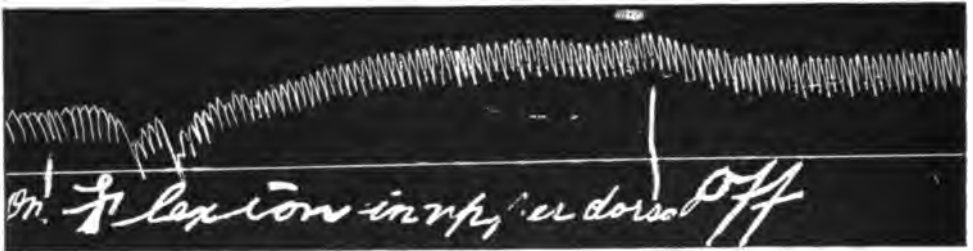

FIG. 10.—This tracing shows the result of artificial flexion, while maintaining a fixed point in the upper dorsal region of the dog. It will be seen that this lesion produced a marked increase in blood pressure (12 millimeters of mercury) as a result of the abnormal stimulation produced.

**Vasomotor Supply to the Pelvic Viscera.**—Fibers of this system (pre-ganglionic) arise from the upper lumbar and possibly the lower thoracic segments of the cord. Post-ganglionic fibers are distributed by way of or from the inferior mesenteric ganglia, and the hypogastric nerves to the arteries of the uterus, vagina, bladder, and rectum. In the male they supply the seminal vesicles, vas deferens, testicles, and prostate glands, in addition to the bladder and rectum.

**Vaso-Constrictors to the Genital Organs.**—These fibers arise from the lower thoracic and upper lumbar segments of the spinal cord, and pass from the lateral chain by way of the hypogastric nerves or by way of the sacral autonomic ganglia to the pudic nerves. These fibers supply vaso-constrictor fibers to the penis and scrotum in the male, and the clitoris and vulva in the female. The vaso-dilators to these parts are described under the distribution of the dilator fibers.



FIG. 11.—This tracing shows a marked decrease in blood pressure resulting from an artificial bony lesion produced in the lower dorsal region of the dog; further showing that perverted physiological conditions of the circulatory regulating apparatus can be caused by bony lesions. The result is due to vaso-dilation.

**The Vaso-Dilators.**—The general methods of demonstrating the presence of vaso-constrictor fibers, as explained above, are also used for demonstrating the presence of vaso-dilators.

The vaso-dilators differ from the vaso-constrictors in certain respects in their physiological action, as follows: 1. The vaso-dilators do not seem to exert a constant tonic activity on the structures supplied, as do the constrictors; 2. Their action is effected reflexly in some instances at least, only during the time of demanded functional activity of the structures which they supply. The dilators of the salivary glands, for example, are active only during the period when secretion is most active, and the same condition obtains in case of the dilators to the penis.

The following groups of vaso-dilator fibers have been positively determined, and it is quite probable that future research will result in the finding of others. It has seemed most logical to group these fibers into two general classes, viz., those which are distributed with the cranial nerves and their subdivisions, and those which originate with the lateral chain ganglia and their subdivisions.

**The Cranial Autonomic Dilators.**—These fibers are distributed with certain cranial nerves as follows: 1. The dilator fibers distributed with the chorda tympani branch of the seventh cranial nerve supply the submaxillary and sublingual salivary glands and the anterior two-thirds portion of the tongue; 2. Those fibers distributed with the tympanic branch of the ninth cranial nerve supply the parotid gland, the mucous membranes of the pharynx, the tonsils and the posterior one-third portion of the tongue.



FIG. 12.—This tracing shows the result of an artificial osteopathic lesion produced in the upper dorsal region of the spine. It will be noted that as the result of this lesion an increase in blood pressure resulted, which became normal after the perverted condition of the spine (the artificial lesion) was normalised. It therefore shows that an artificial bony lesion may produce abnormal effects on the regulatory apparatus of the rate of the heart beat and blood pressure.

**The Spinal Autonomic Dilators.**—These fibers may be classed into two general groups, as follows: 1. Those originating from the cervical spinal autonomies are distributed to the mucous membranes of the lips, the palate, the gums, the nasal cavities and the skin of the cheeks; 2. It is thought by some authorities that vaso-dilators have been demonstrated to exist in the thoracic autonomies which supply the abdominal viscera. These fibers pass by way of the splanchnic nerves; 3. There is also good reason to believe that vaso-dilator fibers from the thoracic spinal autonomies are distributed to the limbs and other somatic parts by way of the spinal nerves of the brachial and lumbar plexuses, in the same way as the vaso-constrictors are supplied to these structures; 4. It has been definitely shown that a group of vaso-dilators are distributed to the external genitals from the second, third, and fourth sacral segments. These fibers rise from the second, third, and fourth sacral spinal nerves, and pass from here to the hypogastric plexus. This group of fibers is known as the *nervi erigentes*. It has been shown that the erection of the penis is caused by these fibers.







**Nature of the Action of Vaso-Dilators.**—In the case of the vaso-constrictors, it is easy to understand how the contraction of the circular musculature of the arteries would cause a decrease in the lumina of the vessels, but it is not so easy to understand how a condition of dilation could be caused by the stimulus of the nerves. One explanation is that the stimulus by way of the dilators inhibits the tonic action of the constrictors, and in this way vaso-dilation is caused indirectly. Another explanation is that some difference in the nature of the stimulus to the fibers may determine the nature of the effect produced. Still another theory is that the action of the dilators may be explained by a possible function of inhibition which the dilator fibers influence upon certain constrictor centers, which reduces the tonic action of the constrictors, thus causing dilation indirectly.

**Parts of Vascular System Supplied by Vasomotors.**—

It is generally considered that the vasomotors, both constrictors and dilators, end in the muscles of the small arteries, and these parts are therefore affected most by vasomotor control. It can readily be seen that the small arteries, since they furnish directly the supply of blood to the various structures, should receive the nerves which regulate the amount of blood supplied. The large arteries do not have the property of dilation and constriction as do the smaller arteries, and they have few or no vasomotor fibers.

It has been demonstrated that some parts of the venous system have vasomotor fibers. Mall has shown that the veins of the portal system receive vaso-constrictor fibers, but other than this it cannot be said that venomotor nerves have been demonstrated.

## CHAPTER VII.

# THE FLOW OF BLOOD THROUGH THE VASCULAR SYSTEM.

If the web of a living frog's foot be fastened under the objective of a microscope the flow of blood may easily be observed. By this means the nature of the flow in the arteries, veins, and capillaries may be studied. It may be seen that the blood moves much more slowly in the capillaries than in the arteries, and that there is no evidence of pulsations. In the arteries and veins the corpuscles are held in the midportion of the stream and constitute what is known as the "axial current," while that part about the axial current, the so-called "inert layer," contains the plasma.

**Circulation Time.**—The time required for one complete circulation, that is, the time necessary for a particle of blood to pass from any one point of the circulatory stream through the system and back to that point of the circuit, is twenty-three seconds, which requires from twenty-five to thirty heart beats. This varies, of course, with the route through the circulatory system, so this figure is given only as an average. Various methods have been used for determining this, but the method used by Hering is probably the one most generally applied. It was done by injecting potassium ferrocyanid into the jugular vein of one side, and testing the contents of the jugular vein of the other side to determine the length of time necessary for its appearance there.

**Velocity of Blood Flow.**—The velocity of the flow of blood varies materially with the kind of vessel through which it is passing, the flow being most rapid in the large arteries near the heart and gradually decreasing as it approaches the capillaries. The

flow of blood in the arteries is not regular, but varies with the heart beat from 150 millimeters per second during diastole to as much as 520 millimeters per second during systole.

In the veins the blood flow is regular, but is much less rapid than in the arteries. The velocity of blood flow in the large veins varies from 60 millimeters to 150 millimeters per second.

In the capillaries the blood flow is regular like that of the veins, but the velocity is very much less, being only about one millimeter per second.

**Variations in Velocity of Blood Flow.**—The velocity of the blood in the arteries varies inversely with the distance from the heart, i. e., the velocity decreases as it approaches the capillaries. This decrease in velocity is caused by the loss of pressure from the heart as the distance from the heart increases, and also by the increase in the area of the blood bed, the total cross section of the small arteries being greater than the larger artery of which they are branches. This factor is much more effective in causing the reduced pressure in the capillaries, as the total cross section of the capillaries is estimated to be about eight hundred times that of the aorta, and the velocity and pressure are reduced in proportion.

The heart beat also influences the velocity and pressure of the blood in the vessels. Anything which causes an increase of heart beat affecting both rate and amplitude, increases the blood flow in proportion to this increase. Conversely, it may be stated that any decrease in the force or rate of heart beat correspondingly reduces the velocity and pressure of the blood.

The blood pressure and velocity are both influenced by the size of the small arteries, as affected by the vasomotor nerves, vaso-constriction causing an increase in blood pressure and a corresponding decrease in velocity, as it will decrease the total amount of blood passing from the small arteries into the capillaries and to the veins. The converse of this statement is also true, viz., that vaso-dilation will cause a decrease in blood pressure, an increase in the velocity, and an increase in the total

amount of blood passing from the small arteries to the veins by way of the capillaries.

There is very little if any variation in the size of the capillaries from any cause. The velocity and pressure in these vessels therefore depends upon the variations in pressure and velocity of the blood in the arteries, of which the capillaries are branches, and the veins in which they terminate. The capillaries are comparatively very short, and the velocity and pressure are both very low. The greatest amount of change of gases from blood to tissue and from tissue to blood occurs through the walls of the capillaries.

**Blood Pressure.** — The blood pressure is greatest in the arteries, varying from 150 millimeters of mercury in the aorta to 110 millimeters or 120 millimeters of mercury in the brachial artery, and continues to decrease toward the periphery. During diastole of the heart the pressure is from 40 millimeters to 50 millimeters of mercury less than during systole. During diastole the pressure in the brachial artery is reduced to from 65 millimeters to 75 millimeters of mercury. This difference in the blood pressure in the arteries is known as the pulse pressure. The blood pressure in the veins is much less than in the arteries, being greatest in the peripheral veins and decreasing as it approaches the heart. In the peripheral veins the pressure varies from 2 millimeters to 10 millimeters or more of mercury, depending upon the location of the vein, its course, etc. In the inferior vena cava the pressure varies from nothing to 2 millimeters to 3 millimeters of mercury. The blood pressure in the veins varies somewhat with the position of the body, but there are no pulsations as in the arteries.

The blood pressure in the capillaries varies from 20 millimeters to 40 millimeters of mercury, depending upon the pressure in the small arteries, the systemic blood pressure, and the pressure in the veins. The flow through the capillaries is regular, as in the veins.

**Methods of Study.**—The blood pressure in the arteries was first studied (Hales, 1733) by attaching an artery of a horse to a

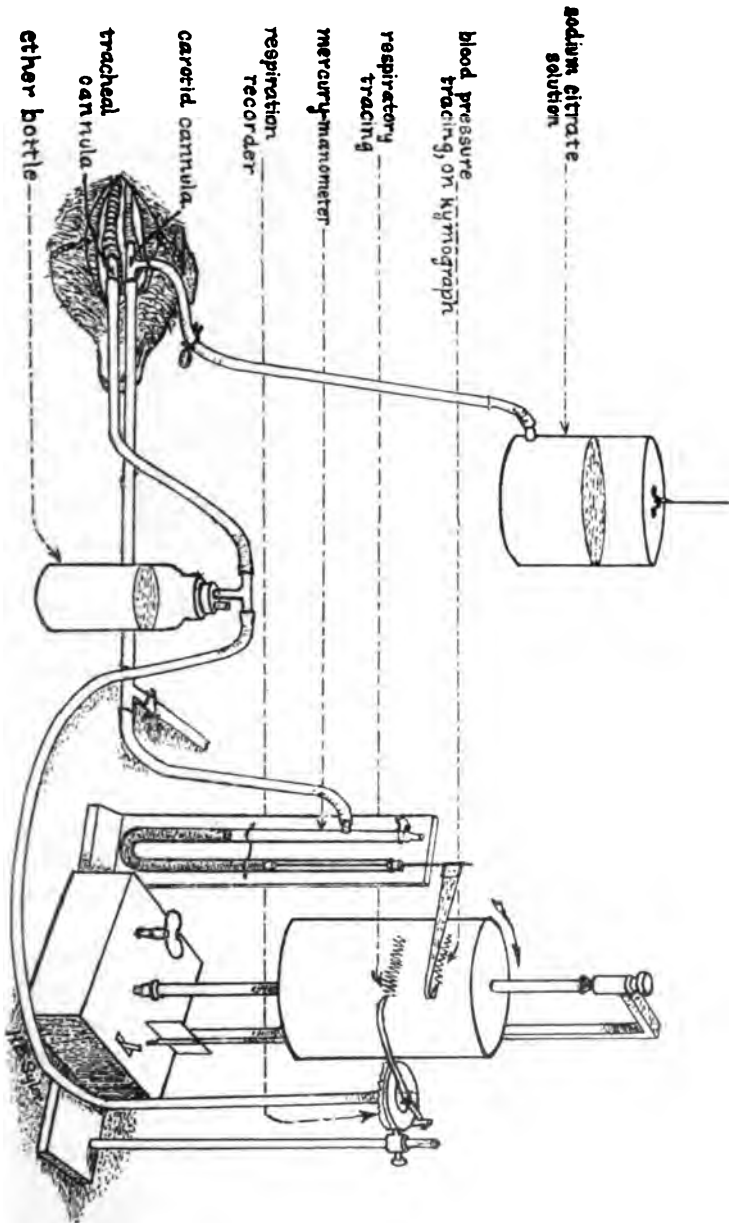

FIG. 13.

perpendicular glass tube, in which the blood arose to a height of eight feet and three inches. In a tube attached to a vein the pressure caused the blood to rise only to twelve inches.

Modern methods of measuring blood pressures consist of the use of certain instruments in which the pressure of the blood acts upon a mercury column. For mammalian work the pressure of the blood is taken from an artery (usually the carotid or femoral) by ligating a three-way glass cannula into the central end of an artery. Another arm of the cannula is connected to a tube leading from a container suspended from three to four feet above the animal. Through the tube leading from this container some fluid (10% sodium citrate) is allowed to flow, filling the bulb of the cannula before the artery clamp is removed from the artery. The third arm of the cannula is attached to a mercury manometer, which consists of a U tube partly filled with mercury. From the open end of the U tube a pointer extends from a float on the surface of the mercury. The manometer is adjusted so the pointer may be made to write on the smoked paper of a kymograph, and in this way the blood pressure and pulse variations may be recorded. If the two columns of mercury in the U tube of the manometer are level when the clamp is removed from the artery and the tube leading from the citrate bottle is closed, the rise of mercury in the open arm of the tube above the level in the closed arm will represent the amount of blood pressure in millimeters of mercury.

For the purpose of determining the blood pressure in the large arteries of the human, another instrument, the sphygmomanometer, is used, of which there are now many good makes obtainable for clinical use.

**Systolic and Diastolic Variations.**—By observing the surface of the mercury column in the manometer when it is attached to an artery of a living animal, or by observing the tracings so made, it will be seen that variations in the blood pressure occur regularly at intervals, and that these intervals correspond exactly with the heart beats. During systole (in the dog) the mercury rises from 20 millimeters to 40 millimeters of mercury



FIG. 14.—This figure shows a modern kymograph, which is used for recording blood pressure and respiratory tracings. The tracing is made by a writing point, which records the result on a smoked paper attached about the drum of the kymograph while the drum revolves. See Fig. 13.



higher than its lowest or diastolic level. In man this variation amounts to from 40 millimeters to 50 millimeters of mercury when taken from the brachial artery, which is known as the pulse pressure. The amount of pulse pressure is greatest in the large arteries near the heart, and decreases as the distance from the heart increases, until there is very little pressure in the small arteries. There is no pulse pressure in the capillaries and veins.

The average or mean blood pressure in the arteries is obtained by taking the average of the systolic and diastolic pressures. It is the diastolic pressure plus one-half the pulse pressure, or it is the systolic pressure minus one-half the pulse pressure.

**Normal Blood Pressure.**—The sphygmomanometer is the instrument most commonly used for determining the arterial blood pressure in man. As has been stated, the normal blood pressure in the adult man taken from the brachial artery is subject to much variation, the difference being caused by pulse pressure, but the average systolic blood pressure varies between 110 millimeters and 145 millimeters of mercury (Faught). The average pressure in the brachial artery for young adults (20 to 25) is stated as 110 millimeters of mercury (Erlanger).

**Blood-Pressure Variations.**—The arterial blood pressure varies directly with age, being from 80 millimeters to 100 millimeters in children; 110 millimeters to 145 millimeters in adults, and from this it may go as high as 200 millimeters or even more in old age. The pressure is usually from 8 millimeters to 10 millimeters less in women than in men. There are also daily variations such as those caused by the taking of food; by sleeping or by muscular exercise. During and after sleep or any kind of physical and mental rest the blood pressure is much reduced, while after exercise or after a meal the blood pressure is much increased. It can readily be seen why the pressure should increase from muscular exercise, but the causes of an increase after a meal are not so readily understood. It would seem that since there is such a marked dilation of the vessels of the splanchnic area (stomach and intestines), the systemic blood pressure would be decreased in proportion. If this should follow with

no compensation, other organs would necessarily suffer from a diminished supply. It seems that this splanchnic dilation is compensated for by an increased activity on the part of the heart, and it will usually be found that blood pressure after a meal is much increased and there is constantly an increase in the pulse pressure, showing that the heart is beating more forcefully.

### **THE PULSE.**

When the ventricles contract, throwing the blood with great force into the arteries, this force is not transmitted directly, but gradually to the peripheral arteries. As the blood enters the arteries from the ventricles they dilate from the force created by the contraction of the ventricles, and gradually resume their original size by virtue of their elasticity. This causes a gradual pressure to be exerted upon the blood contained in the arteries, and since the closed valve prevents a back flow into the heart, a wave of blood is forced toward the capillaries. This graduated force caused by the extensibility and elasticity of the arteries is responsible for the regularly distributed pressure of the blood throughout the vascular system.

When the ventricle contracts and the quantity of new blood is thrown into the aorta, it extends to give room for the increased quantity of blood. After the ventricle has ceased to contract and the walls of the aorta begin to resume their original size by virtue of their elasticity, the column of blood is forced toward the capillaries, as the closed semilunar valve prevents its backward flow. This flow of blood from the heart towards the periphery is known as the pulse wave, and its velocity varies inversely with the extensibility of the arterial walls. If the walls of the arteries are hardened (sclerosis) the pulse wave is transmitted much faster and the blood pressure is increased. The velocity of the pulse wave in normal individuals varies from six to ten meters per second. In old individuals in case of sclerotic arteries or cardiac hypertrophy, or both, the velocity of the pulse wave may be as high as ten to fourteen meters per second.

**The Sphygmograph and Sphygmogram.**—The sphygmograph is an instrument used for making tracings of the pulse wave, and the tracing so made on smoked paper is known as the sphygmogram. The instrument is attached to the wrist in such a way that the pulsations of the radial artery are transmitted to a writing lever, which makes the tracing on the strip of smoked paper as it passes beneath the writing lever. The curve produced by the writing lever and caused by the pulse wave consists of two parts, viz., the ascending or anacrotic limb, and the descending or catacrotic limb.

**The Anacrotic Limb.**—The ascending limb is produced by the sudden impact of blood, which lifts the lever quickly, causing a sudden upstroke. This does not accurately represent the wave, as the apex of the curve is proportionately too high and too sharp. This sharp, high apex is due to a mechanical error, the “fling” of the lever, and does not represent the real form of the pulse wave. The anacrotic limb normally shows no variations, which means that there is a gradual unvarying rise in the pulse wave which causes it. Under certain pathological conditions of the heart, as in stenosis of the aortic valve, a notch may be produced in the ascending limb which is known as the anacrotic notch. This is never present in normal pulse waves.

**The Catacrotic Limb.**—The descending or catacrotic limb is formed during diastole, and represents the gradual descent of the pulse wave. The catacrotic limb, unlike the anacrotic limb, is not a regular curve but shows one or more secondary curves or notches. The most marked of these secondary curves is the one to be observed about the mid portion of the descending limb, and is known as the “dicrotic wave.” Occasionally a less prominent wave between this and the apex, the “pre-dicrotic wave,” may be found.

Post-dicrotic waves are described as following the dicrotic wave, but they are certainly not common. These waves cannot ordinarily be felt in the normal pulse, but the dicrotic wave may sometimes be palpable by the physician or nurse with a highly sensitive touch. The dicrotic wave is often accentuated in

those conditions in which the muscle tone of the walls of the arteries becomes much reduced and the blood pressure becomes low. The dicrotic pulse is often a diagnostic sign of typhoid fever, and may occasionally be found in other infectious diseases. To the palpating finger it feels like two beats occurring in the time of one, the second being less marked than the first.

**Causes of the Dicrotic Wave.**—Many explanations have been offered, but there seems to be no doubt that the following is correct: The closure of the semilunar valves after systole of the ventricles is followed by tendency of the blood to flow back into the ventricle, but this is suddenly checked and the recoil thus produced sets up a second wave which follows the primary pulse wave, and causes a second slight rise in the pulse wave during the descent of the first wave. It may be readily shown by producing a wave in a pan, or better, a trough of water, that the wave nearest the side is reflected in the form of one or more secondary waves which follow the first wave produced, and which move in the same direction with the same velocity. This secondary wave in the normal artery is inconsiderable, but in those abnormal conditions in which the arterial wall is less resistive and the blood pressure is low from peripheral resistance, the secondary pulse wave may be able to cause a perceptible rise, which is the cause of the dicrotic pulse. There are many other conditions of variation in the nature of the pulse wave besides these given, but they occur only under abnormal conditions and belong, therefore, in a course on physical diagnosis.

**Heart Sounds.**—The sounds produced by the normally functioning heart are two in number, the first or "lubb" sound occurring at the beginning and the other, the "dup" sound, occurring at the end of the ventricular contraction or systole. The first sound is caused chiefly by the closure of the auriculo-ventricular valves (mitral and tricuspid), but the contraction of the musculature of the ventricles is also causative of the sound. We may divide the sound into two factors, viz., the valvular element and the muscular element.

The second heart sound, the "dup," is a much shorter and sharper note than the first, and is caused by the closure of the semilunar valves and the vibrations set up by the valves transmitted to the chest wall. That this is the cause of the second heart sound has been shown by holding the valve flaps apart with a wire hook while the heart was beating, in which case no sound was produced, and in various other ways the same cause has been shown to be true.

A third heart sound is sometimes given, which is said to occur very promptly after the second sound, but this can surely not be heard in the average individual. It seems to be audible only in certain cases, and the most delicate apparatus is necessary for its detection. The cause or nature of this sound is unknown.

The clinical value of the heart sounds, while of very great importance, belongs more properly in a course on physical diagnosis, and will therefore be only very briefly given here. Since it is known that the valves of the heart are continuous with the endocardium, it would be natural to assume that any affection of the endocardium would involve the heart valves, causing them to fail in their proper functions. Inflammation of the endocardium is often followed or accompanied by "murmurs" or imperfect sounds, due to imperfect closure of the auriculo-ventricular valves. Any condition of overstrain, etc., which results in dilation or hypertrophy of the ventricles, also prevents the proper closure, and mitral or tricuspid "murmurs" result. The mitral valve is most commonly affected because of the greater pressure on the left side of the heart. In case of a failure in closure of the mitral valve (mitral insufficiency) there occurs at the time of ventricular systole a back flow of blood into the left auricle, and this, meeting the flow from the pulmonary veins, causes a low murmur following the first sound of the heart. If the left ventricle grows sufficiently (hypertrophies) to maintain a normal blood pressure, regardless of this leakage, there may be no harmful results. If this does not occur the back pressure in the lungs and on around to the right heart may cause a failure

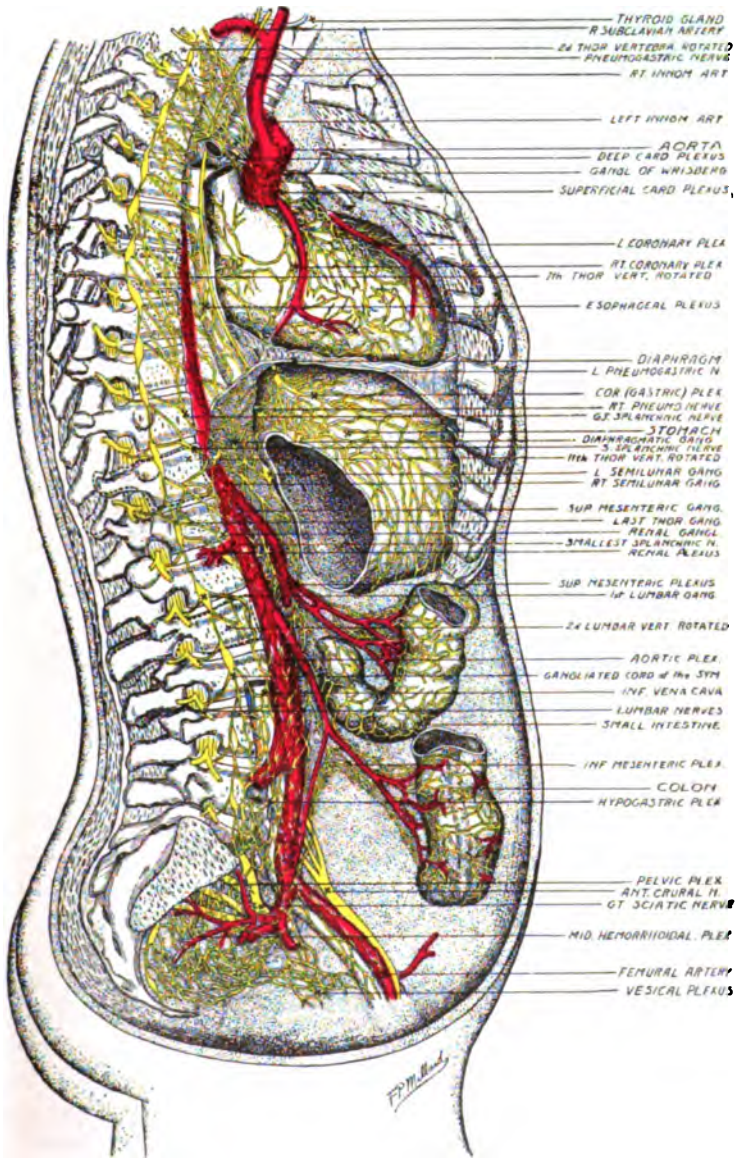

**PLATE IX** —The nerves of the heart and blood vessels. Several spinal lesions are indicated showing disturbance of the nerves supplying internal blood vessels going to the stomach, bowels, etc.



of the right heart to drain the venous blood from the system, and the collection of extravascular fluid in the tissues, or dropsy, may follow.

Other conditions, such as stenosis or narrowing of the lumen of a valve, may occur, which increases the resistance to the blood flow through the valve, and because of this increased resistance greater work is demanded of the musculature of the heart and dilation or hypertrophy results.



FIG. 15.—This figure shows an induction coil, which is used for applying the electrical stimulation to nerve trunks and other structures.

**The Cardiac Impulse.**—In most normal chests careful inspection will reveal an impulse occurring with each ventricular systole at a point (in adults) internal to and below the nipple in the fifth intercostal space. This is known to physiologists and clinicians as the apex impulse, apex beat, or point of maximum impulse, commonly termed the P. M. I. "It is now generally admitted that the 'apex impulse' is caused by the impact of a portion of the right ventricle against the chest wall, and not by the apex of the heart itself." It is not the downward pressure of the heart against the chest wall caused by the systole that



causes the apex beat, as was originally supposed, as during contraction of the ventricles they thicken and shorten, and this would tend to draw the heart away from the chest wall. There are probably three factors causative of the apex beat: First, the hardening of the walls of the ventricles, which makes them more resistant and capable of forcing the chest wall outward; second, the partial rotation of the heart during systole tends to hold it against the chest wall; and third, the tendency of the curved portion of the aorta to straighten when the volume of blood is forced into it from the left ventricle, forcing the heart downward and outward.

## CHAPTER VIII.

# PHYSICAL FACTORS INVOLVED IN CIRCULATION.

**Causes of Blood Flow.**—The chief cause of the flow of the blood through the system is the heart beat. Variations of the rate and amplitude of the heart beat therefore modify the velocity of the blood flow and the blood pressure, the velocity of flow and pressure varying directly with the rate and force of the heart beat. It must be understood, however, that any increase in the rate of heart beat does not always mean an increase in the velocity of blood flow or the blood pressure, as there may be a rapid heart beat with a decreased amplitude or with a decreased vascular tone, which would result in vaso-dilation and a decreased blood pressure.

**Accessory Causative Factors in Blood Flow.**—There are many factors other than the force and rate of the heart beat that materially influence the flow of blood through the vascular system, as follows: 1. Variations in the elasticity of the walls of the arteries have much to do with the blood flow, as it is the recoil of the arterial walls that furnishes the force to the blood after the force from the systole of the heart has been lost. The elastic artery, then, is one of the important causative factors in normal flow, and any variation from this condition must influence the flow. If the walls of the arteries become hardened and their elasticity reduced or lost the blood pressure is much increased, and the opposite condition obtains if the walls of the arteries lose their tone and become flabby. In certain infectious fevers, typhoid for example, the musculature of the arteries becomes very lax and the blood pressure is reduced. A second pulse beat can often be felt because the artery is so flaccid that the

second wave is felt following the first, and the condition is known as a dicrotic pulse; 2. Pressure of contracting muscles, the force of which is exerted upon the veins and capillaries, is another factor that influences the blood flow in these vessels. Muscular exercise therefore aids circulation indirectly; 3. The movements of respiration also influence the flow of blood by causing variations of pressure in the thoracic cavity, which effect the flow of blood towards the heart by decreasing the pressure in the thorax during inspiration. The physical action of the respiration on blood flow towards and into the thoracic cavity will be discussed under the subject of intrathoracic pressure. (See Respiration.) Respiratory movements influence the blood flow in the large veins of the abdominal cavity by increasing the intra-abdominal pressure and in this way causing the blood contained in the vessels to be forced toward the thoracic cavity, where the intrathoracic pressure is at the same time decreased, due to the tendency of the lung to draw away from the thoracic wall in inspiration.

**Conditions Causing Variations in Velocity and Blood Pressure.**—As has been explained above, the rate and force of the heart beat are the most important factors concerned in the velocity of the flow of the blood and blood pressure. 2. The peripheral resistance, determined by the size of the small arteries due to their condition of tone, which is in turn determined by the action of their vasomotor nerve supply, also influences blood pressure and velocity. The mechanism of vasomotor regulation of the size of the small arteries has been discussed under the heading of "The Nerve Supply to Blood Vessels"; 3. The elasticity of the walls of the arteries has much to do with the regulation of the blood flow and the blood pressure as well as acting as a causative factor of blood flow, as has been discussed above; 4. The quantity of blood in the vascular system is another factor in determining the pressure in the vessels. If the blood were evenly distributed throughout the vascular system the pressure would be equal, but this is never the case. The peripheral resistance offered by the capillaries and the force of the heart beat and the elasticity of the arteries constantly maintain a greater

pressure in the arteries than exists in other parts of the vascular system. If, then, the peripheral resistance or the propelling force of the blood be varied it may be seen how the pressure and velocity may be varied accordingly; 5. The hydrostatic effect of the blood influences blood pressure and velocity to some extent according to certain physical laws, as follows: The downward pressure of a liquid column varies directly with the height and density of the fluid, but is independent of the cross section. From the first part of this law it will be seen that long columns of blood lying in a perpendicular plane for any great length of time would have the pressure materially increased at its lower end, which condition occurs in the long veins of the bodies of those who are on their feet for long periods of time. The excessive pressure thus caused often results in distension of the veins involved, causing varicosis; 6. Psychic conditions also influence blood pressure and velocity by causing variations of the vasomotors to the vessels and by affecting the rate and amplitude of the heart beat.

**Effects of Friction from Side Pressure.**—The friction of the vessel walls, or side pressure, causes variation in the rate of blood flow by reducing the velocity of the blood. This resistance varies inversely with the size of the vessel, i. e., the pressure being increased in the smaller tubes and correspondingly reduced in large tubes. This factor affects the flow in the larger arteries very little, as the side pressure is only very slight. The aorta has a diameter (internal) of about 20 millimeters, the diameter of the arteries gradually decreasing in size down to the capillaries, which have a diameter of only about .009 millimeter. From this it will be seen that the side pressure is gradually increased as the blood reaches the periphery, being greatest in the small arteries and the capillaries. The increased resistance to the flow of the blood thus caused helps to maintain a greater pressure in the arteries than in any other part of the vascular system. After the blood has passed the capillaries and entered the larger veins the side-pressure influence is much reduced and the blood is more

free to flow, but the force of the heart beat and the elasticity of the arteries is not active through the capillary resistance, and the velocity is therefore much diminished.

**Some Physical Laws Involved in Blood Pressure and Velocity.**—The chief causes of the circulation of the blood have been given above with the conditions which influence it, causing variations in the velocity of blood flow and blood pressure, but there are certain physical laws involved, as follows: 1. The resistance of the movement of a fluid column varies inversely as the cross section of the tube through which it flows. This factor is of much importance in the study of vasomotor effects, as it explains how the pressure is increased with a general decrease in the velocity in conditions of vaso-constriction and how the opposite effects result from vaso-dilation; 2. The pressure in a moving fluid column varies directly with the resistance. This is another factor to be considered in the study of vasomotor effects, as a condition of vaso-constriction increases the resistance and this increases the pressure in the arteries. By this increased pressure in the arteries and the increased heart beat which follows, the systemic blood pressure will be increased. The influences of side pressure are also active in aiding to increase the pressure, as stated above; 3. The movement of a fluid column varies inversely with the cross-section of the tube through which it flows. The application of this statement can very readily be seen. It is active in influencing side pressure and in conditions of vaso-dilation and vaso-constriction; 4. The velocity of the movement of a fluid varies inversely with the resistance. It may seem at first that this is not true and that the pressure being equal, the blood will flow with a greater velocity through a smaller opening; but taking into account the entire column of blood and the above laws, it will be seen that the flow of the entire column is reduced and that the actual amount of blood supplied to a structure is decreased in proportion to the resistance; 5. Vascular pressure varies inversely with the elasticity of the vessel walls. It can readily be seen that if the contents of the ventricles of the heart were discharged into

rigid instead of into elastic vessels the pressure would be much greater, as the same amount of blood would be contained in a less amount of space. When the ventricles of the heart discharge their blood into the arteries the extensibility of the arteries allows the walls of the arteries to distend and in this way more space is afforded to the blood. The arteries then slowly contract by virtue of their elasticity and: 6. The velocity and arterial pressure vary directly with the rate and amplitude of heart beat. This has been given above, but for the sake of completeness it should be given here. It has also been explained above how there may be an increased rate of heart beat without an increase in blood pressure, as an increase in heart rate is not always accompanied by an increase in the force of the heart beat; but in most cases there is an increase in the force of heart beat with an increase in the rate, as these two functions seem to be influenced by the same kind of stimuli if not by way of the same nerve fibers; 7. Blood pressure varies directly with the quantity in the vascular system. This statement applies more especially to local areas of the body and is active in conditions of congestion. Any excess of blood in a part due to an interference with the drainage or increased resistance to the flow means increased pressure unless there is a compensating dilation of the vessels; 8. Pressure in fluid columns is equal in all directions. This law explains how the blood pressure is not influenced, except by gravity effects, by the direction of the artery or the course it takes. Another law that bears upon this same principle is, 9. That pressure in fluid columns is independent of the shape of the container. These two laws show how the branches of the large arteries have the same pressure and velocity (except for the increased side pressure) that exists in the artery of which they are branches; 10. The fact that fluids have elasticity of size or volume but not of form or shape is also to be considered in the above physical factors concerned in circulation. In cases of vaso-constriction, for example, in which the pressure is increased due to the increased peripheral resistance, according to Boyle's law (volume varies

inversely with the pressure) the blood is compressed but the amount of pressure in the different directions is not affected, and therefore vaso-constriction of a part influences equally the entire area so affected.

# SECTION II

---

## RESPIRATION





## CHAPTER IX.

### GENERAL CONSIDERATIONS.

Respiration includes all of those processes involved in the exchange of gaseous substances of the organism and its environment. These changes consist essentially of the absorption of oxygen and the elimination of carbon dioxide. All living organisms, both animals and plants, require oxygen for their life processes, except a few bacteria—the anaerobic organisms, such as *B. tetani* and a few others.

**External and Internal Respiration.** — By the term “external respiration” is meant the taking of oxygen into the lungs and the supplying of this oxygen to the blood of the capillaries of the alveoli and the elimination of carbon dioxide.

“Internal respiration” is the term applied to the process of the exchange of oxygen and carbon dioxide between the systemic capillaries and the various tissue cells.

**Respiratory Organs.**—In considering the relation of structure to function in the study of the physiology of respiration, it becomes necessary for the student to make frequent references to texts on anatomy and histology. The following review work in these subjects is advised: A careful study of the structure of the air passages, viz., the nasal cavities, the pharynx, the trachea, the bronchi, the bronchioles, and the alveoli or air sacs. Certain points may be considered together with their functions, as 1. That the entire surfaces of the air passages are lined with ciliated epithelium, whose function is that of protection. It does this by carrying out the dust and other foreign particles that may enter with the air. (See structure and function of ciliated epithelium under contractile tissues); 2. The structure of the bronchial tubes and trachea is such that they are not compressible,

and are therefore always open for the free passage of air; 3. The smaller bronchi are both cartilaginous and muscular. This insures that these tubes will remain open, and it is probable that the musculature is regulated reflexly in such a way as to regulate the supply of air to the air sacs; 4. The smallest bronchioles terminate in membranous sacs, the walls of which contain the arteries and capillaries of the pulmonary system, and it is in this way that the blood is brought almost directly in contact with the air in the alveoli. By this mechanism every red corpuscle comes in almost direct contact with the air, and in this way has its contained hemoglobin thoroughly saturated with oxygen.

**The Pleura.**—The lungs, and in fact each lung, is covered by a double layer of membrane, the pleura. The inner or visceral layer covers the lung, and the parietal or outer layer is reflected about the thoracic cavity in such a way that the blind space—the “pleural cavity”—is left between. This is not a space, as the two layers of the pleura always normally lie in immediate contact, with a trace of lymph, the pleuritic fluid, between, to prevent friction during movements of respiration. It may be that under abnormal (pathological) conditions, such as the accumulation of air in this cavity (pneumothorax), caused by puncture, or the growth of gas-producing bacteria, etc., permanent separation of the walls may occur. Again, it may be that infection results in the production of pus, in which condition there may be a collection of pus, or pyothorax, or if there be presence of pus and gas, it is termed pyo-pneumothorax, etc. In such cases recovery is usually followed by the formation of adhesions of the two layers, and the roughened surfaces give rise to the “friction rubs” heard by the ear or stethoscope after recovery from lung affections.

The pleura dips in between the lungs from below and down from above, and completely separates each lung in the mid line. The spaces left between are known as the mediastinal spaces. These again are only potential spaces, as they contain such thoracic viscera as the heart, the aorta with its branches, the pulmonary artery, the pulmonary veins, the ascending and descending vena

cava, the azygos veins, the thoracic duct, the œsophagus and trachea, with the lymph glands and the lymph vessels.

**The Thoracic Cavity.**—This cavity is formed by the walls of the chest and the diaphragm, and constitutes an adjustable cage which is completely filled by the lungs, the heart, and the contents of the mediastinal spaces. The air content of the lungs is constantly being forced out and renewed by the movements of the walls of this cavity. Inspiration is caused by the enlargement of the thoracic cavity, the lungs swelling (due to external air pressure by way of the nasal cavities, pharynx, and trachea) to fill the enlarged cavity. The normal position and size of the thorax may be considered as that which exists at the end of a normal expiration, which means that all of the muscles involved in the act of respiration are at rest.

**Movements and Rate of Respiration.**—Expiration is caused by a diminution in the thoracic cavity (depression of the ribs and elevation of the diaphragm), which forces a part of the contained air out of the lungs. Expiration normally follows inspiration without pause, but there is a normal pause after each expiration and before the next inspiration. The normal number of expirations in the adult varies from seventeen to twenty per minute. This number is subject to certain conditions of variation, such as age, time of day, amount of exercise, etc. In the new born the respirations vary from forty to fifty per minute; in the child of five to ten years the rate varies from twenty-five to twenty per minute, and shows a continual decrease to about twenty or thirty, while in men the rate is about sixteen per minute. After this age is passed the rate often increases until it is about eighteen per minute at the age of fifty.

**Active and Passive Respiratory Movements.** — Any movement of the thoracic walls which increases the size of the thoracic cavity beyond normal, thus causing inspiration, is known as an active inspiration. The converse of this, namely, any movement which decreases the size of the thoracic cavity, thus causing expiration, is an active expiration. Active or forced respiration is not the normal way in which the air is forced from the lungs in

ordinary breathing, but occurs only in deep breathing. After an active or forced expiration the thoracic cavity will return to the normal position (which is the position after a normal expiration) without any voluntary muscular force. This is passive inspiration. After an active inspiration the thoracic walls again return to the normal position without the aid of the voluntary muscles, which act is a passive expiration.

### CAUSES OF RESPIRATORY MOVEMENTS.

To understand the mechanism of the respiratory movements it seems best to describe two classes of movements, viz., the movements of the walls of the chest, ribs, sternum, etc., and the movements of the diaphragm.

**Thoracic Movements.**—A careful examination of the thoracic skeleton will show how the ribs are attached and how they extend downward anteriorly, and how, when the ribs are raised by the contraction of certain muscles, enlargement of the thoracic cavity, both laterally and antero-posteriorly, results from such movement. It is therefore evident that all muscles involved in the elevation of the ribs are inspiratory muscles, as they increase the size of the thoracic cavity. Since, as has been mentioned, the ribs project downward anteriorly, any movement which raises them increases the size of the cavity, and it is equally true that any movement which depresses the ribs decreases the size of the thoracic cavity.

Another factor concerned in the movement of the ribs is the nature of the anterior and posterior attachments. Anteriorly the ribs are attached to the costal cartilages, and when the ribs are raised as in the act of active inspiration, the cartilages are placed in a condition of strain, due to both bending and torsion. They therefore are tending to be forced back to normal by the elasticity of these cartilages. Posteriorly the ribs are attached to the vertebræ at two points by means of facets. The axis of rotation effected by these attachments points not directly outward, but forward and downward, so that as the rib moves

it rotates in a plane which is at right angles to this axis, and this will cause the rib to be moved outward as well as upward.

When the force which has been effective in raising the ribs ceases (the muscle contractions) the walls of the chest are lowered by the elasticity of the costal cartilages and the weight of the thorax.

**Movements of the Diaphragm.**—Since the diaphragm is attached to the lower ribs, the lumbar vertebræ, and the ensiform cartilage, and when at rest extends far up into the thoracic cavity, it will be seen that when contraction of its musculature occurs it will be drawn down, and in this way the vertical diameter of the thoracic cavity will be increased. The diaphragm consists of musculature attached to a central tendon, which is free with the exception of its attachment to the pericardium, which does not interfere with its free movements. In addition to the increased vertical diameter caused by the lowering of the central tendon, the peripheral part of the cavity is increased by lowering of the musculature of the diaphragm. This drawing down of the diaphragm causes a decrease in the intra-thoracic pressure, and the external air pressure forces the lungs down firmly against the diaphragm, thus increasing the content of air in the lungs. There is never at any time normally an actual space between the lungs and the diaphragm, or any other part of the thoracic cavity. It is not suction, but pressure—pressure from the external air—which keeps the lungs in close contact with the thoracic cavity. Another result of the lowering of the diaphragm is the effect upon the abdominal viscera. As the diaphragm lowers, the pressure is increased in the abdomen and the abdominal walls are forced outward. To prevent the lower ribs from being drawn in by the contraction of the diaphragm, which, if it occurred, would tend to decrease the size of the thorax, the serratus posticus and quadratus lumborum muscles contract.

**Innervation of the Diaphragm.**—The muscles of the diaphragm are supplied with motor and sensory fibers by the phrenic nerves. These nerves arise from branches of the third, fourth, and fifth cervical segments, and pass downward on each side through the mediastinal spaces.

That the musculature of the diaphragm is supplied with motor fibers by way of the phrenic can be shown by sectioning one phrenic in the neck region, which causes the cessation of movement of the corresponding side of the diaphragm. To determine this, an incision is made in the median line of the animal just below the ensiform cartilage, and two fingers placed in against the diaphragm. The one side may be felt to contract down against the finger, while the other (the sectioned side) does not. It has been further shown (Porter) that section of one lateral half of the cervical cord above the origin of the phrenics causes cessation of movements of the corresponding side of the diaphragm. This points to the existence of a center in the medulla which sends fibers down to the phrenic of that side. It was further shown (Porter) that after hemi-section of one side above the origin of the phrenics (say the right side) the muscles of that side have quit acting, and if the opposite (left) phrenic nerve be sectioned, the left side of the diaphragm quits contracting and the right side again begins to contract. There has been much discussion as to the central connection by means of which such a seeming paradox could be caused, but it has been quite well explained by the following work: The demonstration of sensory fibers in the phrenic by Deason, by other work done by Carlson, and finally by the work done on series No. 3 by Deason and Robb. (See Part II.) The diaphragm also receives nerve fibers from the lower intercostals, but the phrenic is its chief motor supply.

**Nerve Supply to Lung Tissues.**—The lung receives its nerve supply chiefly from the vagus. Fibers supply the musculature of the air tubes with motor and probably with trophic fibers. It has been shown that the vagus supplies both motor and inhibitory fibers to the bronchial musculature. They are known as broncho-constrictors and broncho-dilators. The constrictors cause a decrease in the lumina of the tubes when stimulated, and the dilators produce the opposite effect. These variations cause in the size of the tube corresponding variations to the resistance of the air supplied to the lungs. Sensory fibers from the alveoli and probably from other parts of the lung are also carried

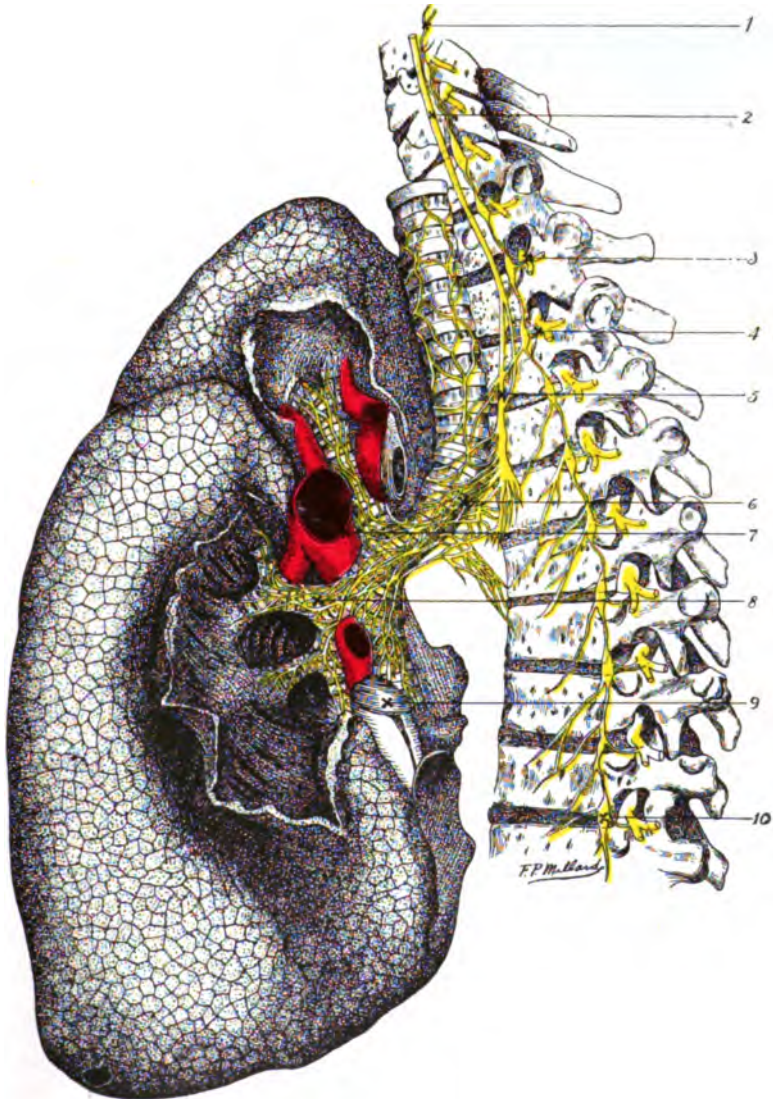

PLATE X.—1-10, Sympathetic chain; 2 and 5, pneumogastric nerve; 3, thoracic spinal nerve; 4, fibers (rami) connecting spinal nerves with sympathetics; 6, posterior pulmonary plexus; 7, pulmonary artery; 8, divided bronchial tubes entering lung tissue; 9, pulmonary vein. The bronchial tubes with their vessels are shown forming as they do the root of the lung, also the lung tissue of the left lung in its relation to the tubes and vessels. The nerve plexuses formed by the pneumogastric and sympathetic, which are distributed to these tubes, are shown in their relation to the spine. Note also the spinal nerves and their communication with the sympathetic chain. By referring to plates 2, 3, 4, 5, and 6, the connections of these fibers with the cord and other autonomic nerves may be seen.





## OF RESPIRATION.

of the diaphragm will

nerve supply chiefly  
 s. The muscles of  
 pply from the spinal  
 cervical and brachial  
 rve supply from the  
 ceive fibers from the  
 receive their nerve  
 abdominal muscles  
 r plexus.

ry and are therefore  
 hand, their power to  
 dent of, voluntary  
 ch is explained by  
 gh the action of a

on of movement, in  
 and the expiratory  
 ounted for by assum-  
 the center.

all voluntary with  
 rolled in such a way  
 iration from failure  
 ut length of time to

This is a bi-lateral  
 ol of the respiratory  
 ody. These centers  
 the medulla at the  
 at the floor. It has  
 cially differentiated  
 be attributed, but  
 ed by mammalian



in the *vagus*. These sensory fibers conduct afferent impulses to the respiratory center or centers, and are probably stimulated normally and at regular intervals by the distension of the alveoli. It is generally considered that this rhythmical stimulation of the respiratory center causes reflexly the action of the respiratory muscles, which cause the normal and rhythmical respiratory movements.

It must be remembered that while the *vagus* is visceromotor to the lungs it really has nothing to do with the movements of the lungs in respiration except reflexly, as explained in the preceding paragraph. The contraction of the musculature of the air tubes as controlled by the *vagus* may have something to do with the amount of air supplied and the rate of respiration, but even this is questionable. The lungs act only passively in the movements of respiration.

**The Muscles of Respiration.**—These muscles may be divided into two groups, viz. those which are effective in inspiratory movements and those which are effective in expiration. Various methods have been employed for the purpose of determining whether or not muscles are active in producing movements of respiration, and also for determining whether they are concerned with movements of inspiration or expiration: 1. If a muscle or group of muscles is so attached that its contraction will tend to raise the ribs or otherwise increase the thoracic cavity, it is commonly considered to be inspiratory in function; 2. If the anatomical attachment is such that the contraction will depress the ribs or otherwise decrease the size of the thoracic cavity, it is considered to be expiratory; 3. If by artificial stimulation by way of its nerve supply or by stimulating the muscle directly, it depresses or lifts the ribs, it is classed accordingly; 4. If the muscle (Martin's method) contracts simultaneously with the contractions of the diaphragm, it is classed as inspiratory, and if it is found to contract alternately with the diaphragm it is classed as expiratory. According to the results of these various methods, the following seems to be the classification most generally accepted:

**Inspiratory Muscles.—**

1. Diaphragm increases the vertical diameter of chest.
2. Elevators of the ribs increase the lateral and antero-posterior diameter of chest.

Levator costarum.

External intercostals.

Scaleni—anticus, medius, and posticus.

Sterno-cleido-mastoid.

Pectoralis minor.

Serratus posticus superioris.

**Expiratory Muscles.—**

1. Those affecting the diaphragm indirectly, the “abdominal press” muscles, which increase the pressure in the abdominal cavity and tend to force the diaphragm upward.

External oblique.

Internal oblique.

Transversalis.

Rectus abdominis.

2. Depressors of the ribs:

Internal intercostals.

Triangularis sterni.

Intercostalis lumborum.

Serratus posticus inferior.

Quadratus lumborum.

Other muscles than those given are active in normal breathing, and while they have little or nothing to do with taking air into or expelling it from the lungs, they should properly be classed as muscles of respiration. They are the accessory muscles of respiration. If one will observe the dog while under ether it will be seen that the nostrils dilate and contract and the glottis moves. These movements, then, are caused reflexly with the movements of the other muscles, and their activity is probably regulated from the respiratory center, as in case of the movements of the other muscles. The muscles that elevate the nares and those that regulate the size of the glottis, and possibly others, should be considered accessory respiratory muscles.

**NERVE SUPPLY TO THE MUSCLES OF RESPIRATION.**

The nerve supply to the musculature of the diaphragm will be found discussed elsewhere.

The muscles of respiration receive their nerve supply chiefly from the cervical and thoracic spinal nerves. The muscles of the neck and shoulders receive their nerve supply from the spinal accessory and various nerves from the cervical and brachial plexuses. The nasal muscles receive their nerve supply from the facial nerve, while the muscles of the glottis receive fibers from the vagi. The thoracic muscles of respiration receive their nerve supply from the intercostal nerves. The abdominal muscles receive nerves from the intercostals and lumbar plexus.

These muscles are all striated or voluntary and are therefore under the control of the will; but, on the other hand, their power to function rhythmically without, or independent of, voluntary control shows a co-ordinated activity, which is explained by assuming that they are controlled through the action of a respiratory center.

The muscles show a double co-ordination of movement, in that the inspiratory muscles act together and the expiratory muscles act together. This again can be accounted for by assuming that they are alternately stimulated from the center.

Since these muscles of respiration are all voluntary with the exception of the diaphragm, they are controlled in such a way that there is no danger of cessation of respiration from failure of the activity of these muscles for a sufficient length of time to cause death from suffocation.

**Action of the Respiratory Center.**—This is a bi-lateral motor center, each side or part having control of the respiratory musculature of the corresponding side of the body. These centers are located on either side of the mid line of the medulla at the level of the calamus scriptorius and beneath the floor. It has never been demonstrated that there is a specially differentiated group of cells to which this function could be attributed, but its functional existence has been demonstrated by mammalian

research work. By making sections through the medulla of the living animal and determining the point at which the functional activity is lost, the location of the center has now been rather accurately located. This center should really be considered as a respiratory center, since in ordinary breathing the inspiration only is active, the expiration being passive in nature. When the breathing is deep and the expirations are also active, the center may act automatically in causing these movements. Some authorities believe there is a separate center for expiration, but this has not been proven.

The efferent fibers (medullary spinal) extending from these centers pass down the cord chiefly on the same side (a few are known to cross to the opposite side) and terminate about the motor cells of the anterior horn of gray matter, from which the fibers (spino-muscular) extend to the various muscles of respiration. Because of the decussation (crossing) of some of these fibers, one of these centers may have some control of the musculature of the opposite side as well as that of the same side. There is good experimental evidence to show that these centers act autonomically, very much as the motor centers to the heart; that is, they have the power of originating their own energy to send impulses. That these centers can be influenced reflexly is also known. By the stimulation of any sensory mixed nerve leading into the cord, such as the sciatic or phrenic, the respiration can be much increased. (See Series No. 3, Part II.)

**Secondary Respiratory Centers.**—There is some evidence of the existence of respiratory centers other than the one described above. These centers are supposed to exist in the cervical and upper dorsal segments of the cord, and it may be that the reflex stimulation of these motor centers by afferent fibers coming from the periphery, as well as those fibers coming from the primary center in the medulla, cause the action of the motor fibers from the cord to the muscles. This has not as yet been positively demonstrated. (See Series No. 3, Part II.)

Some authorities would add other so-called accessory respiratory centers which they hold are located in the brain. Stimulation

of one part of the mid-brain is claimed by Martin and Brooker to cause an increase in respiration. Others have held that these centers regulate the rhythmical activity of the primary center.

**Reflex Effects on Respiration.**—As stated above, the stimulation of any sensory or mixed nerve causes an increase in respiration, which is explained by assuming that this stimulus increases the activity of the respiratory centers. Various other stimuli, such as cold air or water applied to the skin surfaces, mental excitement, etc., also often produce similar effects. It has been shown that stimulation of certain parts of the brain cortex also has this effect, which is caused by the stimulus affecting the center.

**Regulation of the Respiratory Center.** — Since the automatic and rhythmical activities of the center determine the amount of oxygen supplied to the blood and tissues by way of the lungs, it is only natural to suppose that the condition of these structures (blood and other tissues) should in some way, by the law of demand of function, regulate the activity of the center which is to perform this important function. It has been shown how the stretching of the walls of the alveoli initiates the afferent impulses which go by way of the vagi and thus excite the center to normal activity, but how are the changes in rate and amplitude to be caused which increase or decrease the actual amount of oxygen supplied according to the demand of the tissues? It has been shown that the composition of the blood and the quantity of oxygen and  $\text{CO}_2$  determine the action of the center. If the blood becomes highly venous, which means a deficiency in oxygen and a corresponding excess of  $\text{CO}_2$ , this causes an increased action of the center. The converse of this statement is also true, viz., that an excess of oxygen in the blood inhibits (or fails to stimulate) the center. The first condition—the excess of  $\text{CO}_2$  in the blood and stimulation of the center—would cause an increase in respiration which would meet the demands of function and supply the blood with oxygen, while the opposite condition—the excess of oxygen—would depress the activity of the center and decrease the oxygen supply to the system. The arterial blood supplies



the center, and the condition of excess of  $\text{CO}_2$  here merely means a relative increase and not an actual increase, as one might think of venous blood in this sense. Much discussion has occurred as to the nature of these effects, i. e., whether the excess of  $\text{CO}_2$  actually stimulates and the excess of oxygen inhibits, or whether in some other way the result is obtained. There is nothing but theory on this point, and a wide field is offered for research work along this line.

**Tonic Activity of the Afferent Fibers.**—It has been shown that if the vagi are sectioned the respirations are slower and deeper, and it is believed that these nerve trunks carry afferent fibers which stimulate the respiratory center and tend to regulate its rhythmical activity. This tonic activity is probably initiated in the afferent endings in the alveoli of the lungs by inspiration, maintains a certain amount of tone in the center, and furnishes not only the stimulus for the normal rate but also affects the amplitude of the respiratory movements.

Other afferent fibers from the various parts of the respiratory tract seem to have specific function, some being stimulatory and some inhibitory to the movements of respiration. The superior laryngeal and glosso-pharyngeal, which supply fibers to the mucous membrane of the pharynx and larynx, when stimulated produce an inhibitory influence on respiration. It is probable that the glosso-pharyngeal produces a specific effect by inhibiting respiration during the act of swallowing, and that the afferents from the nasal mucous membrane by way of the trigeminal also produce a similar inhibitory effect. In case of the so-called irrespirable gases, such as ammonia, etc., respiration is prevented and this reflex mechanism may be considered as a protective adaptation, protecting the mucous membrane of the respiratory tract from injury.

## CHAPTER X.

### MOVEMENTS OF RESPIRATION.

#### **Normal and Modified Respiratory Movements.** —

Respiratory movements may vary greatly in amplitude and rate under different conditions without being abnormal. The ordinary or quiet respiratory movements, those which occur while the body is at rest, are known as eupnea, while very difficult or fast and deep breathing is known as dyspnea. The term dyspnea, however, is usually not applied to the deep and fast normal breathing which follows muscular exercise, the term being reserved for labored or abnormal breathing. Some authors, however, prefer to class all respiratory movements other than quiet normal breathing as dyspnea and to class dyspneic breathing under different degrees, such as mild, medium, extreme, etc. It should be remembered that in eupnea the inspiratory movements only are active, while the expiratory movements are merely passive.

Normal eupneic inspiration is caused by the lowering of the diaphragm and to some extent to the levator costarum and external intercostals. Normal eupneic expiration is caused by the chest walls returning to normal position without the action of muscles, and is dependent upon: 1. The elasticity of the lungs; 2. The elasticity of the costal cartilages; 3. The elasticity of the abdominal wall; 4. The increased pressure of the abdominal cavity and the weight of the thorax. In dyspnea the various muscles of expiration become active, and the activity of the muscles of inspiration is increased.

Since normal inspiration is caused chiefly by the contractions of the diaphragm and since normal expirations are passive, anything which interferes with normal expansion of the abdominal cavity interferes with normal respiration and the thoracic type of respiration takes its place.

**Diaphragmatic and Thoracic Respiration.**—As has been mentioned before, the movements of the diaphragm are most effective in causing normal inspiratory movements, and this type of breathing is classed as diaphragmatic or abdominal respiration. If the respirations are deep the muscles of the thorax become active, and this type of breathing is known as thoracic or costal respiration. In the abdominal type the diaphragm contracts first, which causes the abdomen to protrude and the movements of the thorax to occur later. Just the opposite of this occurs in thoracic respiration, i. e., the thorax is observed to expand first, which movements are followed by movements of the diaphragm. In the human, abdominal movements of respiration are common to men and thoracic respiration is common to women. "It has been a question whether this difference is a genuine sexual distinction or depends simply upon differences in dress. Hutchinson inclined to the view that it forms what we should call a secondary sexual characteristic, and that its physiological value for women lies in the fact that provision is thus made, as it were, against the period of pregnancy." (Howell.) Hutchison, from a series of tests on young girls who had never worn tight dress, observed that the thoracic type of respiration was natural. There is, however, evidence against this view, in that certain women who have never worn tight clothing breathe normally by means of abdominal respiration as men do, and this would seem to be the more logical conclusion.

**Measurement of Respiratory Movements.**—For the purpose of studying the nature of respiratory movements in animals caused by various kinds of nerve stimulation, etc., a respiratory tambour is attached to the side arm of a T tube, and tracings are made from this which record the frequency and amplitude of the respiratory movements. (See the various series of mammalian work in Part II.)

The exact amount of chest and abdominal expansion may be measured upon man with a tape or by means of special instruments for the purpose.

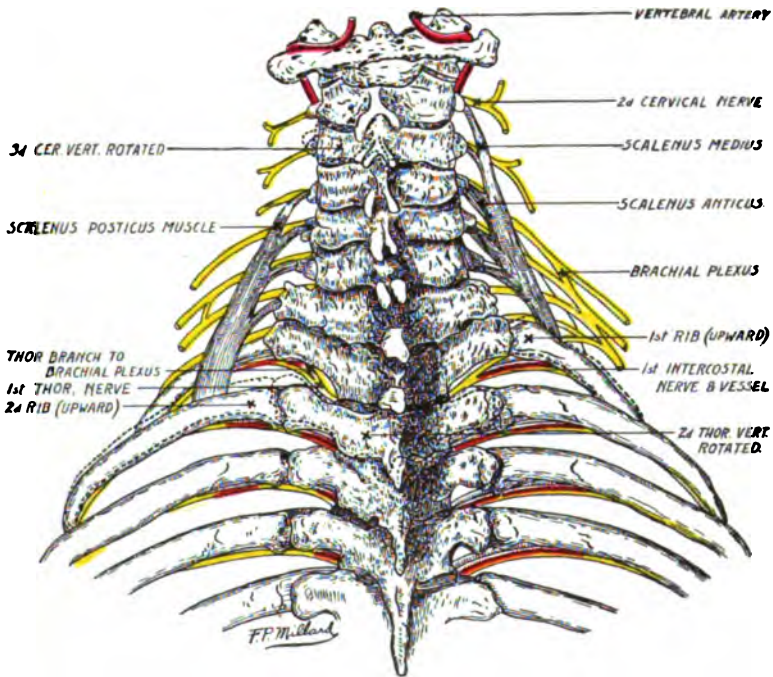

PLATE XI.—Showing cervical and upper dorsal region in which we find the greatest amount of contraction and irritation in bronchial affections. The upper dorsal is commonly known as the bronchial spinal nerve center, and specific corrective work done in that region alleviates bronchial affections. The intercostal nerves are shown coming from the spinal cord, and in their relation to the ribs. The first rib on the right side is shown drawn up by muscular contraction, due in part to the third cervical vertebra being rotated as shown in dotted lines, which irritates the nerve supply indirectly to this muscle. And the second rib on the left side is also thrown upward, partially by a rotation of the second dorsal vertebra, to which this rib is attached. The scalenus posticus muscle is shown attached to its upper border, which aggravates the abnormal position of the rib.



**Measurement of Respiratory Capacities.**—This is done by means of the spirometer, which records the exact amount of air expired, and by the measurement of such volumes of air the various respiratory capacities can be determined.

**Measurement of Breathing Capacities as Determined by the Spirometer.**—

1. A normal expiration after a normal inspiration (tidal air), 500 c.c.
2. Greatest possible expiration (forced expiration) following a normal expiration (reserve or supplemental air), 1600 c. c.



FIG. 16.—This figure shows a modern spirometer, which is used for studying respiratory capacities.

3. The greatest possible expiration after a normal inspiration (supplemental plus tidal air), 2100 c. c.

4. Normal expiration after greatest possible inspiration (complemental plus tidal air), 2100 c. c.

Compare supplemental and complemental air from above results and account for the variation.

5. The greatest possible expiration after the greatest possible inspiration (vital capacity), 3700 c. c.

6. Residual air, 1000 c. c.

7. Minimal, 1000 c. c.

From the results of the above, calculate the quantity of air breathed in twenty-four hours. (Pulmonary ventilation.)

These figures vary of course with sex, age, and with the size of the individual, but they can be very greatly increased by proper methods of respiratory exercise.

**Methods of Producing Artificial Respiration.**—A knowledge of such operations is often needed by physicians, as they may at any time be called in cases of drowning or suffocation from

gas, etc. The method which seems to be in most common use consists in placing the patient upon his back with something under the upper dorsal region to elevate it slightly, but this is not always used. One individual now draws the arms well back over the head, thus drawing the ribs outward and upward and expanding the chest. After this movement the arms are lowered to the normal position or forced slightly against the chest, while a second worker presses upon the chest and abdomen to force more air out of the lungs. In the United States navy usually three individuals are used, one on each arm and a third working over the thorax and abdomen. This is a modification of the Sylvester method. It is essential to make these artificial movements correspond in time to about the normal respiration rate, i. e., eighteen per minute. This work is continued for an hour or longer if there be any signs of recovery at the end of an hour. Recovery has resulted after as long as two hours of such work.

In case of drowning it is necessary to first place the patient head downward and force as much water as possible from the lungs. Placing the patient face downward over some object such as a barrel, and forcing downward and forward, often accomplishes this. It is also necessary to fasten or hold the tongue in such a way that it is prevented from blocking the respiratory passage.

Schaefer's method, as he describes it, "consists in laying the subject in the prone posture, preferably on the ground, with a thick folded garment underneath the chest and epigastrium. The operator puts himself athwart or at the side of the subject, facing his head, and places his hands on each side over the lower part of the back. He then throws the weight of his body forward to bear upon his own arms, and thus presses upon the thorax of the subject and forces air out of the lungs. This being effected, he gradually relaxes the pressure by bringing his own body up again to a more erect position, but without moving the hands."

Artificial respiration can be effected in animals by the application of pressure to the chest at regular intervals, or if the animal is being operated, a bellows may be connected to the trachea and air forced directly into the lungs at regular intervals, allowing the escape as often as the air is forced in.

**Causes of Breathing at Birth.**—Since the foetus does not breathe in utero, one would be inclined to inquire into the causes of the initiation of the first respiratory movements. Several explanations have been offered, as follows: 1. That the stimulation of the cutaneous surfaces as the child reaches the cold air reflexly stimulates the respiratory center to activity. This would hardly hold in those cases in which the child begins to breathe as soon as its nose or mouth is exposed; 2. That the increased venosity of the blood caused by tying the umbilical cord and thus shutting off the placental blood excites the center, but this would hardly hold in those cases in which the child begins to breathe before the cord is tied. It seems most logical to accept both or either of these explanations, as both causes are known to be effective. The stimulation of the skin surfaces by spanking or changing the new born child from warm to cold water is usually effective when the process of respiration fails to begin otherwise.

#### **INTRAPULMONIC AND INTRATHORACIC PRESSURE.**

It has already been explained that the force which at all times holds the lungs against the walls of the thoracic cavity is the air pressure from the outside acting through the nasal passages, pharynx, trachea, and bronchial tubes. This pressure is therefore, with slight exceptions, always equal to the pressure of the outside air. The space between the lungs and the thoracic wall and the spaces between the lungs—the mediastinal spaces—constitute the intrathoracic space in which the lungs are contained. As has been explained elsewhere, these are not real spaces, but are filled at every point by the various thoracic viscera. If the thoracic wall were held distended and the lungs were rendered inextensible, then the thoracic cavity would be actual rather than potential, as it is in the normal chest of living animals. This can readily be demonstrated in mammalian operations by making a puncture through the thoracic wall of one side, leaving the other unaffected. The lung on the punctured side will



suddenly collapse because of the sudden admission of air into the thoracic cavity of that side, which equalizes the pressure on both sides, and since these forces are equal, the elasticity of the lung tissue is enough to cause the contraction, drawing the lung away from the chest wall.

The pressure within the lungs is known as intrapulmonic pressure, and is always equal to (with slight variations) the outside air pressure. The pressure in the thoracic cavity—intrathoracic pressure (outside of the lungs and inside of the thoracic walls)—is always, with slight exceptions, less than the intrapulmonic pressure. Intrathoracic pressure is equal to the intrapulmonic pressure less the force exerted by the elasticity of the lung, which causes it to tend to draw away from the thoracic wall.

**Causes of Decreased Pressure in the Thorax.**—The lungs are developed from outgrowths of a part of the foregut, which is a part of the common tube from which the entire alimentary canal and its glandular structures are formed. The lungs in their process of growth and development are formed in a compressed thoracic cavity, as the thorax in embryo and foetus is compressed by the anterior flexion of the head and chest and by the large size of the liver in proportion to the liver of the adult. This causes the lungs to be comparatively small in proportion to the space they have to fill, when after the birth of the child the thorax expands. The lungs therefore are too small to fill the thoracic cavity without tending to draw away, and this elastic force or tendency to draw away from the walls of the thorax is one cause of the decreased intrathoracic pressure. This negative pressure does not occur suddenly after birth, but gradually develops as the thoracic wall grows, and the thoracic cavity is thus increased.

The negative pressure in the thoracic cavity is maintained by the power that blood and other body fluids have of rapidly absorbing air which may get into this cavity accidentally. It may be shown that, after one lung has been made to collapse by puncture of the diaphragm or the lateral thoracic wall, if this

opening be tightly closed the collapsed lung will soon become extended and the negative pressure will be restored.

**Variations in Intrapulmonic Pressure.** — Since, as explained in the above paragraphs, the lungs are always exposed to the external air pressure, the lungs except while being affected by movements of the chest walls, that is, while at rest, are held distended by a pressure of air which is exactly the same as that of the external air. This is at sea level equal to 14.7 pounds per square inch, or 1033.3 grams per square centimeter, and sustains a mercury column of 760 millimeters, and is known as a pressure of one atmosphere. The intrapulmonic pressure at the beginning and end of inspiration, while the lung is quiet, is therefore equal to one atmosphere or the external air pressure, whatever that may be.

This pressure varies during the active movements of respiration, being increased during inspiration because the external air does not pass into the lungs fast enough to maintain the normal pressure while the thoracic cavity is expanding. The exact converse of this condition obtains during expiration for, as the chest wall sinks rapidly to normal, the intrapulmonic pressure is increased while the air is being forced from the lungs. The amount of variation in pressure during inspiration and expiration varies with the amplitude of the respiratory movements, these variations being greatest in the deep, quick respirations. These variations in intrapulmonic pressure are not great, being from six to ten millimeters of water pressure in ordinary breathing and from thirty to one hundred millimeters of mercury in forced breathing. (Donders.) Any pathological condition which decreases the lumina of the air passages, such as inflammation of the nasal cavities or in fact inflammation of any part of the respiratory tract, particularly the glottis and bronchial tubes, causes increased variations in the intrapulmonic pressure and renders respiration more difficult.

In the modified movements of respiration, such as sneezing, coughing, etc., the intrapulmonic pressure is often very greatly varied. These excesses in variation as well as those caused by

the constricted glottis and bronchial tubes, are sometimes sufficient to materially affect the action of the heart and circulation.

**Variations in Intrathoracic Pressure.**—As stated above, the term intrathoracic pressure refers to the pressure within the thoracic cavity, i. e., the spaces between the two layers of the pleura, which includes the lateral and mediastinal spaces. The pressure in the thoracic cavity (the so-called negative pressure) is always less than the intrapulmonic pressure because of the elasticity of the lung tending to draw the lung away from the thoracic wall. "Intrathoracic pressure, in fact, may be defined as intrapulmonic pressure minus the elastic pull of the lungs." (Howell.)

The average pressure in the thoracic cavity (intrathoracic pressure) during the time the lungs are at rest (at the end of expiration) has been estimated to be 4.5 millimeters of mercury less than the intrapulmonic pressure. At the end of inspiration while the thoracic walls are distended and the elastic force of the distended lungs is increased, tending to draw away from the chest walls, the intrathoracic pressure is decreased to as much as seven or eight millimeters of mercury less than the intrapulmonic pressure.

The intrapulmonic pressure therefore varies inversely with the distension of the lungs, as the greater the lung distension the greater the elastic force which tends to pull them away from the thoracic wall. Intrathoracic pressure therefore decreases as the depth of inspiration is increased.

Taking as an average of the intrathoracic pressure the average pressure in the thorax at the beginning and end of inspiration, it would be about six millimeters of mercury less than the intrapulmonic. Considering the intrapulmonic pressure to be 760 millimeters of mercury, the intrathoracic pressure would be 754 millimeters of mercury. Considering the time of the respiration pause, during which the pressure is less (same as at the end of expiration), the average intrathoracic pressure would be less than 754.

Under abnormal conditions, such as forced breathing, dyspnea, coughing, sneezing, etc., the intrathoracic pressure varies more

than under conditions of normal breathing. In deep inspirations the intrathoracic pressure may be decreased to twenty-five or thirty millimeters of mercury less than the intrapulmonic pressure.

Variations in the intrathoracic pressure, like variations in the intrapulmonic pressure, occur during inspiration and expiration and vary in the same way.

**Effects of Respiratory Movements on the Circulation.—**

Since the intrathoracic pressure is less than the intrapulmonic pressure, and because the intrathoracic pressure varies with the respiratory movements, these conditions will affect the flow of the blood and lymph whose vessels lie within or extend to the thoracic cavity. The pressure in the thoracic cavity where the large veins enter the heart is several millimeters of mercury less than the pressure along the course of these veins, and this assists in the blood flow towards the heart. During the movements of respiration the variation in pressure exerts a so-called "suction-pump" action on the blood in the veins and also on the lymph, which tends to "draw" the blood into the thoracic cavity at intervals and causes the incoming respiratory pulsations of venous blood and lymph. During this period of aspiration caused by thoracic inspiration the diaphragm is drawn down and there is an increased pressure in the abdominal cavity, which, because of the increased pressure exerted upon the abdominal vena cava and vena azygos major, tends to force the blood upward into the thorax where the pressure is decreased.

There is probably no direct effect exerted upon the arteries of the thoracic cavity, because of their thick walls and the high internal arterial pressure.

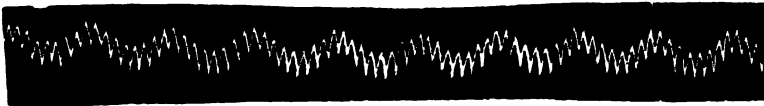

FIG. 17.—This figure shows the result of normal respiration on blood pressure. The increased blood pressure as shown in this tracing occurring at regular intervals is a result of inspiration, the pressure on the vessels of the thoracic and abdominal viscera causing an increase in blood pressure. This is explained in another way by assuming that the vaso-constriction center is stimulated to activity rhythmically.

**Effects of Respiration on Blood Pressure.**—In mammalian experiments if the blood pressure and respiratory tracings be taken simultaneously, it may be seen that there is an increase in blood pressure occurring during inspiration and a decrease during expiration. Various explanations have been offered, but the most probable one seems to be that during inspiration there is a greater quantity of blood forced into the aorta, because of the increased pressure and the increased rate of heart beat which occur during inspiration. Another theory offered to explain these variations in blood pressure assumes that it may be due to a rhythmical action of the vaso-constrictor center acting simultaneously with the respiratory center. It is supposed that the same cause which stimulates the respiratory center to activity (most likely the afferent impulses to that center) at the same time stimulates the vaso-constrictor center, causing its activity.

## CHAPTER XI.

# CHEMICAL AND PHYSICAL CHANGES OF RESPIRATION.

It has already been stated that the chief purpose of respiration is that of supplying the various body cells of the animal with oxygen and relieving them of their gaseous wastes. "Just as the circulation provides for the exchange of fluid materials between the blood and the tissues, so respiration provides for the exchange of gaseous materials between the environment and the blood, and between the blood and the tissues." (Luciani.) It is stated that even the anærobic bacteria utilize oxygen in their metabolic processes, so it is seen that all living organisms require some means of respiration. A great majority of living organisms use free oxygen, some of the simpler forms taking it directly through their cell walls, while others (the more highly differentiated forms of life) have specialized structures, such as the lungs and gills, by means of which they collect oxygen from the air and water. In these higher forms there are two distinct processes, internal and external respiration, as has been previously discussed.

**The Physics of Respiratory Changes.**—The inspired air is warmed to body temperature or nearly so, and as this requires the using of a certain amount of body heat energy, body temperature is so much reduced at every expiration. The expired air is also known to be almost saturated with water vapor which is taken from the lungs. At each expiration, then, there is a certain reduction in the body moisture. This may be readily observed in cold weather, when as the air is exhaled it is quickly cooled and the water vapor can be plainly seen. This absorption of water vapor from the lungs is another means of reduction of the body temperature, and in some animals (the dog) respiration constitutes

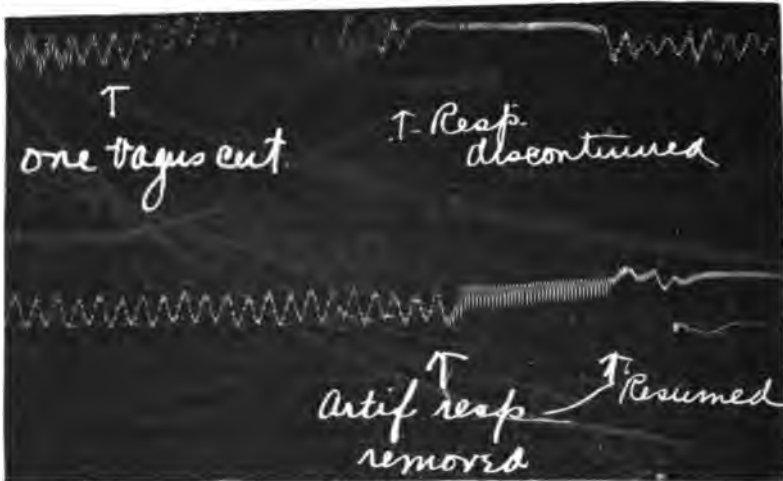

FIG. 18.—This tracing shows the rhythmical variations in blood pressure. It will be noted that when the respiration is discontinued the blood pressure remains normal, which shows that the respiratory movements either directly or reflexly influence the rhythmical variations of blood pressure.

the chief method of reducing body temperature. This is purely a physical change, as the reduction of temperature comes as a result of the reduction of water to vapor and the absorption of heat energy. It is a well-known physical principle that when liquids are reduced to gases this change is accompanied by an absorption of heat energy, and in this case the heat energy taken comes from the lungs. Since the lungs are so thoroughly supplied with blood, the circulating blood is thus cooled and the temperature of the entire system is thus indirectly reduced. The moisture given up to the inspired air also comes from the blood, so respiration is therefore a method of reducing the water content of the blood as well as reducing its temperature.

**The Chemistry of Respiratory Changes.**—The essential constituents of the air with which we are concerned in the study of respiration are oxygen, 20.96; nitrogen, 79; carbon dioxide, .04, and a few other things such as water vapor, dust, etc., which are to be considered as accidental constituents and occur in

variable quantities. Howell gives the following relations of inspired and expired air:

	N	O	CO <sub>2</sub>
Inspired .....	79	20.96	0.04
Expired .....	79	16.02	4.38
		4.94	4.34

It will be seen from these differences that during respiration the used air has gained in CO<sub>2</sub> but has lost in oxygen. It may also be seen that the loss in oxygen is greater than the gain in CO<sub>2</sub>, which means that not all of the oxygen has been used in oxidizing the carbon to form CO<sub>2</sub>, but that some has been used in some other way. It is most likely that this excess of oxygen is used in oxidizing some of the hydrogen of the food stuffs, the result being the formation of water. Traces of other gases, such as methane, hydrogen, etc., are found in expired air, which get into the blood possibly from the fermentation changes occurring in the alimentary canal.

**Gaseous Changes in the Alveoli.**—Since the air in the alveoli or air sacs comes into almost direct contact with the venous blood of the lung capillaries, it is here that the gaseous changes occur which relieve the venous blood of its excess of CO<sub>2</sub> and replenish it with oxygen. It is evident that the air in the alveoli will have a higher percentage of oxygen than the expired air, as much of the inspired and expired air never reaches the alveoli and therefore remains unchanged.

Diffusion of CO<sub>2</sub> takes place from blood to alveolar air, and just the reverse for oxygen. The oxygen taken into the blood unites with the hemoglobin of the blood, forming oxyhemoglobin, in which form it is carried to the systemic capillaries. The venous blood of the alveolar capillaries becomes almost completely saturated with oxygen, containing about nineteen cubic centimeters of oxygen per one hundred cubic centimeters of blood. Practically all of the oxygen of the blood is carried in the red corpuscles by the hemoglobin, but a slight trace may be carried in the plasma. "Not quite the whole of the oxygen is in chemical combination with the hemoglobin; a small fraction of it (0.1 to 0.2 vols. per



cent) is normally held in solution in the plasma. This quantity is, however, less, under normal conditions, than what can be absorbed by an equal volume of distilled water at the same temperature. It may vary according to the Henry-Dalton law, i. e., the volume of oxygen dissolved in the plasma is proportional to its tension." (Luciani.) It is assumed by the physical theory that the forces which cause the exchange of gases in the lungs are the same as those which cause the diffusion of gases generally, and that this change is effected according to the same laws that regulate diffusion under other conditions. It may be stated that in general, if two gases or two solutions of a gas under different pressures be separated by an animal membrane, parchment paper, or other permeable membrane, the gases will pass through the membrane in one or both directions until the pressure is equalized. The results of physiological research have rather definitely demonstrated that the exchange of the gases in the lungs is effected by this physical process.

**Gaseous Changes in Tissue Capillaries.**—After leaving the lungs the blood loses very little or none of its oxygen until it reaches the various capillaries to which it is to be distributed. The blood therefore reaches the capillaries of the tissues almost thoroughly saturated with oxygen, containing about 19% by volume, i. e., in one hundred cubic centimeters of blood there would be nineteen cubic centimeters of oxygen. It has been shown that all or practically all of the oxygen lost during its circuit through the system is lost in the capillaries, for while the blood enters the capillaries with its 19% of oxygen, it leaves the capillaries with only 12% of oxygen. It is most probable that the same physical changes occur, and the same physical causes are responsible for the separation of the oxygen from its unstable compound of oxyhemoglobin and the passing of this free oxygen through the thin wall of the capillary to the cell, that are responsible for similar changes in the alveoli of the lungs. It seems reasonable that the passage of CO<sub>2</sub> from the tissue spaces back to the blood is caused in the same way, i. e., by the laws that govern diffusion of gases through a membrane. In the tissue spaces

lying just outside of the capillaries, if the cells have been active, i. e., if they have been undergoing metabolic changes,  $\text{CO}_2$  and other cell wastes are produced, which increase the " $\text{CO}_2$  pressure" or tension in the intracellular spaces, and therefore there is a tendency for the  $\text{CO}_2$  to pass from these spaces through the capillary wall to the blood. There is also, because the oxygen in the tissue cells has been used, a low "oxygen pressure" or tension on the tissue side, a tendency for the oxygen to pass from the blood through the capillary wall to the tissue cells. This difference in pressure results in the supply of oxygen to the various tissue cells which are in need of oxygen, as the arterial blood passes through the capillaries.

**Carbon Dioxide in the Blood.**—The method by means of which  $\text{CO}_2$  is carried in the blood differs very materially from that of oxygen. A small percentage of the  $\text{CO}_2$  is carried in physical solution in the blood plasma, and some is also probably held physically in the corpuscles, but the greatest amount of  $\text{CO}_2$  is held in chemical union with certain alkaline metals in the form of salts, such as acid sodium carbonate ( $\text{HNaCO}_3$ ), etc. It is supposed that these compounds disintegrate while the blood is passing through the capillaries of the lungs, and in this way the  $\text{CO}_2$  is liberated. It has been suggested that there is some experimental evidence to justify the assumption that the  $\text{CO}_2$  may be held in proteins of the blood very much in the same way as oxygen is held in the hemoglobin.

In addition to the oxygen and  $\text{CO}_2$  of the blood there is some nitrogen present, which is held in physical solution.

**Effects of Breathing Impure Air.**—Every one has experienced the depressing effects such as drowsiness, mental and physical depression, and sometimes headache, which follow the breathing of expired air in poorly ventilated rooms. One may remain in a closed room for a length of time without noticing any effects other than drowsiness and mental depression, or possibly not even this, but if he goes into the open air for a while and then returns to the room which has been left closed he will immediately detect the foul odor. It is not so noticeable if one stays constantly in

the room while the air is becoming foul, because the olfactory sense organs become so fatigued that it is not possible to detect the odor. The cause is not so much due to the repeated breathing of the  $\text{CO}_2$  which is in too great amounts, but to the lack of sufficient oxygen, the latter having been used up by the continued breathing. The expired air also contains an excess of water vapor, dust, etc., and such conditions may become bad enough to cause death. There are some reasonably good results from experimental evidence to show that expired air contains some organic toxic substance other than  $\text{CO}_2$ , which will in time result in death of those animals which have been made to breathe it for long periods of time, but it has not as yet been shown what this substance is if it really exists.

Carbon dioxide, when present in quantities of 4% or more, causes rapid breathing and some distress, and at 10% blueness of the skin, deep depression, headache, and other symptoms result. If the percentage of  $\text{CO}_2$  be increased beyond this amount the symptoms of depression vary with the amount of increase.

From the above it will be seen that while a small percentage of  $\text{CO}_2$  may be present in the air of the living room without causing any marked symptoms, even this is not good, and since it is known that expired air even in small quantities is not conducive to the best physical and mental work, it is necessary to have all living rooms and sleeping apartments thoroughly ventilated at all times. A good rule to follow for ventilating living rooms and sleeping rooms is to endeavor to keep the air on the inside of the room as nearly the same as possible as that of the outside air, avoiding drafts and dust. To do this many plans of ventilation have been devised, many of which are impractical. The reader is referred to some text on sanitation and hygiene for these various methods. The average living or sleeping room can be well ventilated by placing a piece of heavy cardboard or roofing paper at the top and bottom of the window (if there are two or more windows in the room it can be placed at the top of one and the bottom of another) in such a way as to direct the incoming air upward, thus preventing the draft from striking into the lower part of the

room. The lower opening will allow the air to pass out freely. The shield should be placed over a sufficiently large area of the window that the window may be opened at least a foot from top and bottom, as large openings will not cause such sharp drafts as smaller ones. If an indicator is needed suspend a feather near the upper opening, and so long as it is moving the room is being well ventilated. This is a simple but very practical method of ventilating living rooms and the sick rooms where special arrangements for ventilation are not provided for.

Various methods have been devised for keeping the oxygen and  $\text{CO}_2$  in their proper proportions, but these methods have never been thoroughly satisfactory.

## CHAPTER XII.

# ABNORMAL RESPIRATORY MOVEMENTS AND OTHER CONDITIONS AFFECTING RESPIRATION.

The term eupnea is applied to normal respiration, caused by the automatic and rhythmical activity of the respiratory center. Dyspnea is any marked increase either in the rate or force of respiration. This term is also used to denote labored breathing, and may be caused by any of the causes given above which increase respiratory movements. Hypernea is a term applied to marked dyspneic respiration, usually referring to the beginning of dyspnea. Apnea means the total lack of respiration, but the term is often used synonymously with suffocation or asphyxia. The normal cause of decreased breathing is excessive respiration, which over-supplies the center with oxygen.

**Modified Movements of Respiration.**—This term is applied to those movements caused by the action of the various respiratory muscles reflexly or semi-reflexly, not resulting in respiratory movements which are intended to supply oxygen to the blood. The acts of sneezing, coughing, laughing, sobbing, yawning, and possibly vomiting, should be included in this list. These movements are not in any way purposeful, so far as the normal functions of the lungs are concerned. They are for the most part reflex.

**Cheyne-Stokes Respiration.**—This condition is a variation from the normal respiration, which consists of augmentations of respiratory movements with intervals of partial or complete apnea between. The respirations begin after a pause of some twenty to forty seconds and gradually increase, and after from five to twenty such movements have occurred they gradually

decrease and finally cease, and another period of rest follows. There is nothing regular or definite about either the period of respiration (the dyspneic phase) or the period of apnea.

The causes of Cheyne-Stokes respiration are not understood, but it is supposed that by some means there is an abnormal or irregular supply of oxygen or  $\text{CO}_2$  or both, to the respiratory center.

Cheyne-Stokes respiration has been known to occur rather constantly in certain pathological conditions, such as fatty degeneration of the heart, uremic poisoning, arterio-sclerosis, etc. In those cases of Cheyne-Stokes respiration in which there is an increased intra-cranial pressure there is an increase in blood pressure and pulse rate during the dyspneic phase, and the converse, i. e., a fall in blood pressure and pulse rate, occurs during the apneic phase. In those cases in which the Cheyne-Stokes respiration is not accompanied by an increase in intra-cranial pressure there is a decrease in blood pressure and pulse rate.



FIG. 19.—This figure shows a condition which resulted from an artificial bony lesion produced in the upper dorsal region. The tracing shows a condition comparable to Cheyne-Stokes respiration.

**Effects of Exercise on Respiratory Movements.**—Every one knows that muscular exercise increases the respiration in both rate and amplitude, and that the increase varies with the exercise. It will be readily seen that this prompt response in the respiratory apparatus is in answer to a demand of function, for the muscular exercise has increased the tissue metabolism, and this by the rapid use of the tissues' supply of oxygen furnishes a need for its replacement. The wastes of tissue metabolism, principally  $\text{CO}_2$ , must also be renewed and this, too, calls for increased respiration.

The cause of this increased respiration seems to be due more to the stimulating effects of products of muscle metabolism, e. g., lactic acid, acid phosphates, etc., than to the excess of  $\text{CO}_2$ . These products of muscle metabolism when discharged into the blood stream are supposed to stimulate the respiratory center, thus causing the increased activity.

**Effects of Variations in Oxygen and  $\text{CO}_2$ .**—An increase in the  $\text{CO}_2$  content of air to three per cent, as shown by Zuntz, is sufficient to cause hypernea, and a percentage of from eight to ten per cent causes marked dyspnea. After a percentage of ten or fifteen per cent is reached, increased concentration is followed by a depression of the respiratory movements, and death results at a concentration of from forty to fifty per cent. There are no convulsions, the animal dying as if given a lethal dose of some narcotic.

It has never been shown by physiological research that the breathing of pure oxygen has any beneficial effects on the body oxidations. It is known that there is normally an excess of oxygen in normal air, i. e., there is more than is actually needed, and it seems that any increase above this amount is unnecessary. It is claimed by Bert that an excess of oxygen becomes toxic, and is therefore not only a disadvantage but dangerous. Homeothermous animals are killed by a pressure of pure oxygen amounting to three atmospheres. This oxygen pressure causes the blood to contain twenty-eight volumes of oxygen per one hundred cubic centimeters of blood, the excess of oxygen being held in solution in the serum and is not contained in the hemoglobin of the corpuscles.

Decreased percentages of oxygen cause no marked effects until the oxygen is decreased about one-half the normal amount present in air. If the oxygen content of the air is reduced to ten per cent or less, the hemoglobin no longer carries its normal amount of oxygen and the tissues receive a deficient oxygen supply, which condition is known as anoxemia.

If the atmospheric pressure is reduced to 250 millimeters of mercury (Bert), convulsions and death result. At this pressure

the air contains about seven per cent oxygen. In cases of asphyxia death results from the lack of oxygen instead of the increase of CO<sub>2</sub>.

**Effects of High Altitudes.**—Symptoms of headache, nausea, vomiting, vertigo, and general muscular weakness result in those individuals who go abruptly from low to extremely high altitudes. It is stated that these effects commonly occur in those who ascend in balloons to a height of 3,000 meters (9,800 feet) or more. This condition is commonly known as mountain sickness and is said to occur in tourists who try to climb to high altitudes, but while undoubtedly some effects do occur in individuals who have weak constitutions when they go as high as 10,000 feet or more, the results of those altitudes are often very much overestimated. In my own studies into these effects, having had occasion to live at an altitude of nearly 8,000 feet for several years, I am thoroughly convinced that the results as commonly stated are highly fallacious. An individual whose system is weakened by some infectious or constitutional disease, or who is for any reason not physiologically normal, will quite naturally note his inability to do as much muscular work after having gone from a very low to a comparatively high altitude, such as a change from 1,000 feet or lower to an altitude of 6,000 or 8,000 feet or more, but even in these cases I have never observed symptoms of headache, nausea, vomiting, etc., that could be attributed to the effects of the altitude until a height of 10,000 feet or more had been reached, and this commonly occurs in those individuals (if they are otherwise normal) who over-exert themselves and who try to go from very low to very high altitudes. Any normal individual can within a few months, or even a shorter time, become so acclimated that other than "shortness of breath," he will experience no evil effects from altitudes of from 10,000 to 15,000 feet.

If extremely high altitudes are reached, as in those cases in which men have ascended to 7,000 or 8,000 meters or more, extreme muscular weakness and general depression occur at a height of 7,000 meters or more, which continues until the individual becomes unconscious at about 8,000 meters. Death has occurred



at this height, while some individuals have survived even greater altitudes.

Much theorizing and experimenting have been done to determine the causes of these symptoms, but as yet no definite results have been obtained.

**Effects of High Pressures.**—The effects of high pressures have been studied in divers', submarine, and caisson work. If under such conditions the pressure is increased to from four to six atmospheres or more, evil (toxic) effects result as a consequence of the high oxygen pressure, and death is caused by a pressure of from fourteen to sixteen atmospheres.

The symptoms from working under ordinary high pressures usually occur when the worker returns to the normal air pressure and not while working under the high pressure. The symptoms are muscular pain, congestion, dyspnea, and sometimes paralysis. It is stated that if the worker goes gradually from the high pressures to the normal air pressure these effects do not occur. It is believed that the evil effects are a result of the sudden liberation of the pressure on the gases of the blood, resulting in the formation of bubbles, which tend to prevent the flow through the capillaries.

**The Respiratory Quotient.**—The respiratory quotient may be defined as the amount of  $\frac{\text{CO}_2 \text{ eliminated,}}{\text{O}_2 \text{ absorbed}}$  the result of which is always normally less than one. Ordinarily, in an individual living on an average mixed diet, the respiratory quotient varies from 0.6 to 0.9. This difference is due to the fact that an excess of oxygen is used in oxidizing a certain amount of hydrogen, forming water. Under varying conditions, such as a strictly carbohydrate diet, the respiratory quotient may equal unity, i. e., the  $\frac{\text{CO}_2 \text{ eliminated}}{\text{O}_2 \text{ absorbed}} = 1$ . In this case it may be that the excess of oxygen in the carbohydrate is used in oxidizing the hydrogen, and sufficient oxygen thus remains to unite equally with the carbon, resulting in  $\text{CO}_2$ . A diet of fat, on the other hand, reduces the

respiratory quotient (about 0.7), because the percentage of oxygen present in the fat molecule is comparatively low and therefore a greater amount of oxygen is needed for its oxidation.

The respiratory quotient for protein foods is higher than that for carbohydrates (about 0.8), but it is variable because the percentage composition of the protein molecule is not constant, and also because the proteins vary in their amount of oxidation. The respiratory quotient is not materially varied by muscular exercise, except when the muscular work is long continued. The respiratory quotient may in rare cases exceed unity if the pulmonary ventilation is markedly increased or if continuous deep breathing is practiced, as this furnishes a greater amount of oxygen in proportion to the  $\text{CO}_2$  to the alveoli. An increase in the respiratory quotient during convalescence from infectious diseases may, and usually does, occur. This is due to the conversion of carbohydrate food rich in oxygen to fats which have a lower oxygen content, the excess of oxygen being set free to be used in sparing the normal amount of oxygen supplied by the lungs. The excess of fat is stored in the body. There is in such cases an excess of  $\text{CO}_2$  in the expired air, which may come from the breaking down of the carbohydrate molecule as it is disintegrated and formed into fat, but this chemical process is not well understood.



# SECTION III

---

## DIGESTION AND ABSORPTION AND ENZYMES



## CHAPTER XIII.

### FOODS.

The useful constituents of the materials commonly used for foods may be divided into five fundamental groups, viz., carbohydrates, proteins, fats, water, and inorganic salts. Some authorities choose to name a sixth group, the albuminoids, which belongs to the protein group, but varying from proteins in that they have a different nutritive value.

By the term food stuffs or proximate principle of foods is meant those substances which in various ways are absolutely necessary for the maintenance of life. A food in the physiological meaning may be defined as any material which, when taken into the body, may by the process of metabolism be converted into heat or some other form of energy (carbohydrates and fats), or which furnishes material for the formation of living tissue (proteins) or body fluids (water and salts), and which is not in any way detrimental to any of the normal physiological processes.

**Composition and Function of Food Stuffs.** — Carbohydrates consist of carbon, hydrogen, and oxygen, the hydrogen and oxygen being in proportion to form water. Carbohydrates are found chiefly in the starchy vegetables—potatoes, beans, bread stuffs, milk, cereals, etc. Oxygen is required for the oxidation of their carbon, which action results in the formation of  $\text{CO}_2$ . The hydrogen and oxygen set free in the reaction form water. Carbohydrates are the chief source of body energy. The changes undergone during their metabolism are mainly exothermic, which means that the reduction of the complex molecule to simpler and more stable compounds is accompanied by the production of heat energy. Body heat energy, muscle energy, etc., thus result from carbohydrate metabolism.

Proteins consist of carbon, hydrogen, oxygen, and nitrogen, and are found chiefly in lean meats, albumin of eggs, beans, peas,

etc. Protein is the only foodstuff that can build tissue, and this is its main function. The exothermic changes from its metabolism furnish some energy.

Fats consist of carbon, hydrogen and oxygen, and are found in the fatty foods such as meats, olive oil, nuts, and some oily vegetables. Fats take no part in tissue building or the formation of body fluids, but yield heat by oxidation for heat energy and work.

Inorganic salts such as the chlorides, sulphates, carbonates, etc. of sodium, potassium, calcium, magnesium, iron, and some other metals function in maintaining the normal density of the various body fluids, blood, lymph, etc., in forming essential constituents of internal secretions, and in performing certain specific functions, such as iron in hemoglobin.

Water is not a tissue builder or energy producer, but is absolutely necessary to diet. The chief functions of water are to aid in the regulation of body temperature, to aid in the metabolic functions of other foods by acting as a menstruum or solvent, and by forming the proper concentration of the body fluids.

The following list, taken from Howell, shows some of the most common foods and their relative food values:

In 100 parts.	Water.	Protein.	Fat.	Carbohydrates.		
				Digestible.	Cellulose.	Ash.
Meat .....	76.7	20.8	1.5	0.3	...	1.3
Eggs .....	73.7	12.6	12.	.....	...	1.1
Cow's milk .....	87.7	3.4	3.2	4.8	...	.7
Human milk .....	89.7	2.	3.1	5.0	...	.2
Wheat bread .....	35.6	7.1	0.2	55.5	0.3	1.1
Rice.....	13.1	7.0	0.9	77.4	0.6	1.
Peas and beans .....	12-15	23-26	1.5-2	49-54	4.7	2-3
Potatoes .....	75.5	2.0	9.2	20.6	0.7	1.0
Cabbage .....	90.	2-3	0.5	4-6	1-2	1.3
Fruit .....	84.	0.5	.....	10.	4	0.5

The vegetable foods, as may be seen by reference to the list, are comparatively high in their carbohydrate content, and the meats comparatively high in protein and fat. Yet many of the vegetables are also rich in protein, especially the leguminous foods such as beans and peas, but the protein of meats is generally more easily and completely digested than those of vegetables.

This is largely because the cellulose capsule of the vegetable foods prevents the action of the digestive juices. A very thorough boiling of such foods renders digestion easier.

### ENZYMES.

Substances which have the power of producing fermentation were formerly divided into two groups, the living or organized ferments, such as yeast cells, bacteria, etc., and the non-living or unorganized ferments, or enzymes, such as those produced by living cells of the animal organism; for example, ptyalin, pepsin, trypsin, and so on. There is now, however, good experimental evidence to show that this difference will not stand, as many of the so-called enzymes have properties similar to the living ferments.

Most authorities now consider that enzymes act similarly to chemical catalytic agents, that is, that the enzyme merely hastens the action or chemical changes occurring between other substances without undergoing any change in itself. The general term ferment includes, then, all of these substances the chemical composition of which is undetermined, which effect such changes in the living body. They may be defined as those substances produced from living cells, which in the presence of other substances increase the chemical changes without furnishing any chemical energy to the reaction, without undergoing any change in themselves, and which are specific in their action.

**General Properties of Enzymes.**—1. It is generally considered that enzymes are formed from a forerunner or zymogen material, which is found in the granular substance of a secreting gland. This granular substance may be demonstrated in the gland after a period of rest, and it is generally considered that these granules result from certain physiological changes of the cell substance of the gland. It is known that in some cases the formation of these substances is regulated by the nerve supply of the gland, which nerve is termed the trophic or nutritive nerve to the structure.



2. **SPECIFIC ACTIVITY.**—All enzymes are very specific in their action, which means that they do only one kind of work. Ptyalin, for example, has no effect on proteins or fats but acts only on carbohydrates, and here it does only a certain part of the reduction, leaving the work to be finished by another enzyme, maltase. This specificity of action probably holds for all enzymes.

3. **TEMPERATURE REQUIREMENTS.**—The optimum temperature of an enzyme, or that temperature at which it acts best, is from 37° to 40° C. or body temperature. Their action varies inversely with any marked increase or decrease from the optimum; that is, if the temperature be increased beyond this point their activity is reduced and their action is completely destroyed at from 70° to 80° C. If the temperature be reduced their activity decreases, but they are not destroyed by freezing.

4. **COMPLETENESS OF ACTION.**—The action of an enzyme is complete; that is, it will effect entire reduction if the end products (products of digestion) be removed as the action proceeds. The removal of the end products used in body economy is normally effected by absorption.

5. **CONCENTRATION.**—The quantity of enzyme necessary for complete action seems to be very small. If the temperature and reaction be kept right and the end products removed, the slightest amount of an enzyme will effect the complete reduction of a large quantity of material. Dilution of the enzymes often hastens their reaction. It has been shown that if enzymes are highly diluted with normal salt solution and the above conditions kept right, digestion is oftentimes materially hastened. (Deason and Robb.)

6. **REACTION REQUIREMENTS.**—Some enzymes require a neutral or slightly alkaline medium (ptyalin); some require an acid medium (pepsin), and some may act in either an alkaline, neutral, or acid medium (pancreatic lipase).

7. **SOLUBILITY.**—Enzyme substances, generally speaking, are soluble in water and glycerine and are precipitated by alcohol.

8. **REVERSIBILITY.**—Under certain conditions, it seems that some enzymes (lipase) have the power of reproducing the original substance or substances from certain end products. The reconver-

sion of such substances into their original forms after having once been reduced is known as a reversible reaction.

9. ACTIVATION.—It has been found that solution alone of the zymogen material is not always sufficient to render the contained enzyme active. There are other substances known as enzyme activators. Organic activators are known as kinases. Entero-kinase of the intestinal juice, which activates trypsin of pancreatic juice, is an example. There is another class of substances which assists the activity of enzymes, the co-enzymes or co-ferments, an example of which is the influence of bile salts on lipase. (See digestion of fats.)

### CLASSIFICATION OF ENZYMES.

Enzymes are commonly classified according to their functions in the process of digestion, the most important of which are given in the following table:

#### CARBOHYDRATE REDUCERS (DIASTATIC).

Name of enzyme.	Where produced.	Function.
1. Ptyalin, a salivary diastase.	Salivary glands; principally the parotid.	Reduces starch to sugars, maltose.
2. Amylase, a pancreatic diastase.	Pancreas.	Reduces starch to sugars.
3. Invertase.	Intestines—principally duodenum.	Reduces cane sugars to dextrose and levulose.
4. Maltase.	Salivary glands and pancreas.	Reduces maltose to dextrose.
5. Liver diastase.	Liver.	Reduces glycogen to dextrose.
6. Muscle diastase.	Active muscle.	Reduces glycogen to dextrose.
7. Lactase.	Intestines.	Reduces lactose to dextrose and galactose.

#### PROTEIN REDUCERS (PROTEOLYTIC).

1. Pepsin.	Stomach wall.	Reduces proteins to peptones and proteoses.
2. Trypsin.	Pancreas.	Reduces proteins and protein products to simpler forms.
3. Erepsin.	Intestines.	Reduces peptones to simpler products.

#### FAT-SPLITTING ENZYMES (LYPOLYTIC).

1. Lipase (Steapsin).	Pancreas.	Reduces neutral fats to fatty acids and glycerine.
-----------------------	-----------	--

There are a great many other enzymes, some of which will be discussed elsewhere, but the ones given above are the most important.

### MASTICATION.

Mastication is the process by means of which food stuffs are ground between the teeth and thus reduced to a triturated mass suitable for swallowing and digestion. The movements of the mandible in mastication are always voluntary, while none of the movements of other viscera concerned in digestion are entirely voluntary. The mandible is so articulated that a great variety of movements is possible, such as the direct raising of the jaw against the superior maxillary by contraction of the masseters, internal pterygoids, and temporal muscles. Depression of the jaw is effected chiefly by the digastrics. Lateral movements of the jaw are effected by the external pterygoids acting singly, and extension of the jaw is caused by the combined action of both external pterygoids. Other movements are the result of combined actions of two or more of these muscles. The tongue, muscles of the cheeks—the buccinators—and the lips also aid in keeping the food between the teeth.

**Deglutition.**—The swallowing process is commonly divided into three stages: The passage of the bolus of food first through the mouth, which is a voluntary act; second, the passage of the bolus through the pharynx; and third, the passage of the bolus through the œsophagus to the stomach. The two latter stages are caused by reflex, and are for the most part entirely independent of the will.

The first stage is begun by raising the tongue against the hard palate, which forces the bolus backward through the isthmus of the fauces. The food must be moist in order that this act may be properly carried out, as dry foods materially inhibit the action.

The second stage, the passage through the pharynx, must be effected quickly, since the pharynx also furnishes a passage for the air to the trachea, and respiration must be inhibited during the act. The impetus given to the bolus by the contraction of

the mylo-hyoid muscle in the floor of the mouth, and the contractions of the pharynx suddenly force it into the œsophagus.

The opening into the nasal cavities is temporarily closed by the raising of the soft palate, after the bolus has passed into the pharynx. The mouth cavity is closed from the pharynx by the raised tongue against the roof of the mouth, and by the contraction of the pillars of the fauces. The laryngeal opening is temporarily closed by the constrictors of the glottis, approximation of the vocal cords, the elevation of the larynx, and lowering of the base of the tongue. It is questionable whether the epiglottis plays any important part in the operation. The time required for this stage is about one second.

The third stage, the passage of the food through the œsophagus, is caused by peristalsis of the muscles of its walls, and consists of a wave of dilation in front and constriction behind the bolus of food, as in other movements of the alimentary canal. The time required for this act is about six seconds for solids and about one-tenth of a second for the passage of fluids. When the mass of food reaches the cardiac sphincter, its progress is here retarded and the bolus slowly passes through into the stomach, five to eight seconds being required for the passage through the lower end of the œsophagus and the cardiac sphincter.

The nervous control of the act of swallowing is mainly reflex: Afferent fibers from the soft palate and fauces by way of the superior maxillary division of the fifth cranial, afferent fibers from the pharynx by way of the fifth, ninth, eleventh and twelfth cranial nerves to the "swallowing" muscles. There is supposed to be a deglutition center in the medulla through which these movements are regulated, but this has not been demonstrated.

That the movement of progressive peristalsis in the œsophagus is largely caused by reflex has been shown by sectioning the œsophagus or cutting out a portion of it, in which case the movement proceeds to the lower segments after having been started above. It is explained by assuming that the afferent stimulation from one segment excites the center or centers, and in this way the wave is continued by reflex.

## CHAPTER XIV.

### SALIVA AND SALIVARY DIGESTION.

**The Glands.**—There are three pairs of glands, which in order of size and importance are the parotids, the submaxillaries, and sublinguals. The parotid or lateral glands weigh from twenty to thirty grams each. The duct of Stenson empties the secretion into the mouth opposite the second upper molar teeth, is about 40 m. m. in length and 3 m. m. in diameter. Their nerve supply, like that of all other salivary glands, is derived both from the cranial and spinal autonomies. Their cranial nerve is the tympanic branch of the ninth cranial or nerve of Jacobson, whose chief functions to the gland are secretion and vaso-dilation. The spinal autonomic (sympathetic) nerve supply is derived from the cervical autonomies and goes to the gland by way of the arteries supplying it, which are the posterior auricular, temporal, and transverse cervical.

The submaxillary glands weigh from seven to ten grams each, are located below the jaw in the anterior part of the submaxillary triangle, their ducts (Wharton's) are about 45 m. m. in length and empty their contents into the mouth on either side of the frenum of the tongue.

The cranial nerve supply is derived from the seventh cranial and goes to the gland by way of the chorda tympani, and the spinal autonomies are derived from the cervical sympathetics and go to the gland by way of the arteries which supply it, viz., the facial, lingual, and sublingual. The sublingual glands weigh from three to four grams each, and are located beneath the mucous membranes of the floor of the mouth. There are from eight to twenty small ducts (ducts of Rivinus) and one large duct (Bartholin's) which open into the mouth cavity. The cranial nerve

supply is the chorda tympani from the facial, and the spinal autonomic supply is from the submaxillary ganglion by way of the arteries supplying the gland, viz., sublingual and submental arteries.

**The Functions of the Nerves** to these glands may be demonstrated by direct stimulation of the peripheral end of each nerve leading to the gland. If the peripheral end of the cranial autonomic fibers to the gland be stimulated, the results are: A reddening of the gland, a decrease in blood pressure of its vessels, a decrease of the granular material stored up, and an increase in the pressure of the secreted fluid in the duct of the gland, showing that there has been an increased secretion which has not resulted as a process of filtration, as the blood pressure in the gland was decreased during the time of the excessive flow.

If the peripheral end of the cervical autonomic fibers to the gland be stimulated, the converse of the above results may be observed, viz., the vessels of the glands are constricted, the blood pressure is increased, there is an increase in the formation of zymogen granules in the glandular substance, the secretion is diminished in amount but is increased in specific gravity, and it seems to be richer in protein content. These nerves may therefore be considered trophic in that they control the building up of zymogen material from glandular substances. The same functions hold for the spinal and cranial autonomies of all of the salivary glands.

The most reasonable theory of salivary secretion is that during the resting stage the glands store up zymogen material from cell substance, which function is due to the spinal autonomic fibers, and the discharge of this material is caused by the activity of the cranial fibers. Since these fibers are also vaso-dilator to the glands, it can be seen that the excess of blood makes possible the increased amount of fluid necessary for solution of the granules, and this constitutes the two essentials of the secretions. If the chorda tympani nerve be cut in the living animal, the gland will begin to secrete after a few days and may continue for weeks.

This is known as the paralytic secretion, but eventually the gland atrophies and secretion ceases.

The secretion of these glands is controlled by reflex mechanism, the afferent impulses going principally by way of the ninth cranial and lingual nerves from the mouth and tongue. Stimuli by these pathways stimulate the secretory center of the medulla to activity, and efferent impulses are sent out to the glands by way of the chorda tympani and Jacobson's nerves. That the mechanism is a reflex may be shown by cutting the efferent nerve, thus preventing secretion when food is taken into the mouth. The so-called psychic secretion—the flow of saliva which results when an animal is shown food—is probably caused by afferent stimulation of the secretory center in the same way as the afferent nerves from the mouth and tongue excite the glands to activity.

**General Properties of Saliva.**—This fluid is colorless, opalescent, translucent, has a specific gravity of about 1.004, is almost neutral or amphoteric in reaction, being alkaline to litmus and acid to phenolphthalein. Saliva contains about .5% organic solids and certain salts such as phosphates, cyanides, sulphates, chlorides and carbonates of sodium, potassium, calcium and lithium. It also contains from 40% to 60% of CO<sub>2</sub>, which is mostly in the form of carbonates. The most important constituents are physiological contents, viz., the enzymes ptyalin and maltase, which are its starch reducers, and mucin, which serves as a lubricant of the mouth and œsophagus during swallowing. Other than these, there may be named some incidental constituents of saliva, such as salivary corpuscles or broken-down leucocytes, epithelial scales, and bacteria, of the latter of which there are normally present from fifty to one hundred different species in the human mouth. The amount of saliva secreted in twenty-four hours varies from 1000 to 1500 cubic centimeters.

**Variation in Secretion.**—The parotid gland secretes a fluid rich in ptyalin and deficient in mucin, while the exact converse is true of the other glands. There is a marked variation in the enzyme content of saliva of different species of animals. The dog, for example, has no ptyalin in its saliva, but it is very

rich in mucin. It has never been demonstrated that the enzyme content can be changed by varying the diet. A carbohydrate diet in man, for example, will not increase the quantity of ptyalin in his saliva.

**Functions of Saliva.**—The chief function of saliva in the human is the digestive changes which result from the action of ptyalin or salivary diastase. It converts boiled starch to maltose and dextrin, the intermediate stages of the reduction being not fully known. Maltase reduces these products to the simpler sugars. This action begins in the mouth and continues in the stomach. (See "Digestion in the Stomach.") Another important function of saliva is lubrication, which is chiefly due to the mucin. Still another function is that of solution of dry foods, making taste possible, and which also assists in the formation of a bolus of the food for swallowing.

**Conditions Necessary for Salivary Action.**—Ptyalin acts best at a temperature of from 37° to 40° C. There is no action at 0° C., but the enzymes are not destroyed by freezing. They are destroyed by a temperature of from 60° to 80° C. Salivary enzymes act best in a neutral or slightly alkaline medium, and thorough cooking of the starches materially aids their reduction.

**Osteopathic Considerations.**—Dr. Burns has shown that lesions of the jaw cause marked variations in salivary secretion. See report of her findings in Part II.



## CHAPTER XV.

### GASTRIC SECRETION AND DIGESTION.

Gastric secretion begins a few minutes after food is taken into the mouth. The food does not need to be taken into the stomach to cause secretion of gastric juice. The effect is produced by afferent stimulation to the secretory center in the medulla, and the efferent stimulation goes to the stomach by way of the vagi.

**Methods of Study.**—The Pawlow fistula or second stomach is made by surgical operation on dogs, preparing a second stomach separated from the first by a layer of gastric mucosa and having an outlet in the abdominal wall. Secretion in this way can be collected from the second stomach free from food at any time during digestion. The œsophageal fistula is made by section of the lower end of the œsophagus and making an outlet so that food swallowed is not taken into the stomach, but passed to the outside. The animal, when fed a “sham meal,” in this way produces the secretion of gastric juice in the stomach by reflex mechanism, but the juice is not contaminated with food and may be collected for experimental purposes.

**Test Meal.**—The individual or animal is given a certain quantity of food, usually consisting of one shredded-wheat biscuit, and a certain length of time after eating the contents of the stomach are taken by stomach tube. This is the most common method in use for the study of pathological secretions in the human. Beaumont's method is so well known that it needs no lengthy discussion here. His classical experiments on Alexis St. Martin, who had from a gun-shot wound an open fistula in the stomach, offered an excellent opportunity for study. Carlson has recently been doing some work on a similar case.

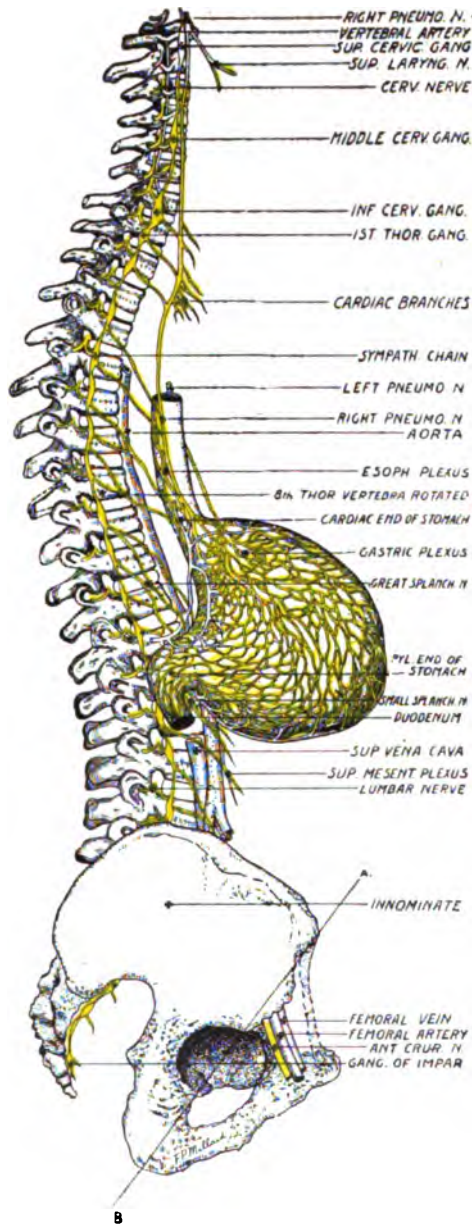

**PLATE XII.**—Side view showing nerve supply to the stomach. Eighth thoracic vertebra is rotated, showing interference with splanchnic nerves. Note the communication existing between the spinal nerves and sympathetics. Pneumogastric nerves are also shown.



## SECRETORY NERVES OF THE STOMACH.

**The Vagi.**—That these nerves are secretory to the stomach we have the following evidence: First, that if the vagal branches to the stomach be sectioned, there is no secretion from a “sham meal” or from showing the dog food. Second, stimulation of the peripheral end of the vagi produces gastric secretion after a latent period of from five to twenty minutes. There is also some experimental evidence to show that the splanchnics are secretory to the stomach, but they are not as important as the vagi.

**Secretagogues and Hormones Another Essential Cause of Gastric Secretion.**—Secretagogues such as the soluble substances of meats, meat extracts, soups, etc., directly excite the gastric glands to activity by acting as a stimulus to the local nerve plexuses exciting a peripheral reflex, or by causing the pyloric mucous membrane to produce a chemical substance, secretin, a gastric hormone, which the blood carries to the gastric glands, stimulating them to activity. There is good experimental evidence to bear out the theory. (Edkin's, Starling's Physiology, 1912 ed.; Howell, 1911.) A hormone is a chemical substance produced in one structure, which, when absorbed into the blood stream, excites to activity some other structure. It is probable that the hormones of the stomach are produced as a result of the activity of the secretagogue acting on the pyloric mucous membrane.

There are, then, two essential causes of secretion: The nervous mechanism initiates and is responsible for the greater part of the flow. Hunger and appetite are the normal sensations which stimulate the flow of gastric juice at the outset. The hormones continue the secretion after the “appetite juice,” due to the mental or brain effects and the vagal effects, have ceased.

**Effects of Variation of Food on Gastric Secretion.**—The first secretion of a meal, the “appetite juice,” is unaffected by any variation in food. (Pawlow.) But the second, the hormone or chemical secretion, is much increased by meats. It has however, the greatest digestive power following a bread diet. Pawlow has

suggested that this may result from variation in stimulus to the gastric mucosa. This theory is not generally accepted. Large quantities of oils diminish the secretion of gastric juice.

**Effect of Drugs on Stomach Secretion.**—Gastric secretion is increased by acid and diminished by alkalies. The administration of alkalies also diminishes secretion of pancreatic juice and other alimentary secretions, which possibly explains the causes of certain secretory disturbances from drugs.

**Gastric Digestion.**—The purpose of digestion is the preparation of food stuffs for absorption.

**Starch Digestion.**—Digestion of starches from the action of ptyalin in the saliva swallowed with the food continues for some time in the fundic end of the stomach. It is later inhibited by the action of the hydrochloric acid of the gastric juice.

**Protein Digestion.**—Pepsin is formed in the chief cells of the gastric tubules. It may be formed from a zymogen (propepsin) like ptyalin. Peptic zymogen is changed to pepsin by the action of hydrochloric acid. Native proteins by the action of pepsin are reduced to peptones, according to Kuhne, by several intermediate stages, such as acid albumin or syntonin, primary proteoses or protalbumoses, and secondary proteoses or dutoalbumoses. For the mechanism by which these changes are effected the reader is referred to works on physiological chemistry. Pepsin acts only in an acid medium. Peptic digestion is therefore a result of the combined action of pepsin and hydrochloric acid.

There are several conditions which influence the action of pepsin. It acts best at an optimum temperature of from 37° C. to 40° C. Its action is destroyed at 80° C. like other enzymes, and reducing the temperature inhibits its action. The normal amount of hydrochloric acid in gastric juice is from .2% to .4%. Any marked variation from this decreases the activity of pepsin.

Hydrochloric acid inverts cane sugar to glucose and fructose, reduces some proteins to a jelly-like mass, assists in precipitating caseinogen of milk, and probably hydrolyzes some of the dextrin and maltose resulting from the action of ptyalin on starch.

**Rennin, Rennet, or Chymosin.**—This enzyme is formed also in the chief cells and is present in them in the form of a zymogen or a prorennin. It, like pepsin, also acts in an acid medium. The milk upon which it acts is quickly reduced to a solid clot, which, like blood clot, soon contracts, pressing out its liquid portion, the whey. Human milk forms a more flocculent clot than cow's milk. The reaction requirements are proper temperature and an acid medium, the clotting time varying inversely with the amount of rennin present. Rennin is used commercially in cheese making. By the action of rennin casein is first reduced to paracasein; this by the action of calcium phosphate forms the clot, which is an insoluble calcium salt. The exact nature of the chemical changes is unknown. The curd so formed is digested by pepsin of the stomach and by the trypsin in the small intestine. This latter process is proteolytic, resulting in proteoses, etc.

**Lactic Acid.**—Bacterial fermentation of carbohydrates in the stomach results in the formation of sugar and lactic acid, but this action does not continue, as it is stopped by the hydrochloric acid of the gastric juice. During the early stages of digestion only, carbohydrates are digested by fermentation and by the action of salivary enzymes.

**Gastric Lipase** secreted in the stomach reduces some of the finely divided fat as during the first stages of gastric digestion. This action is also assisted by the dilute hydrochloric acid. The process is hydrolytic, reducing fats to fatty acids, but the greatest amount of fat digestion occurs in the duodenum. (Starling, 1912.)

Artificial gastric juice for experimental purposes may be prepared by adding glycerine to macerated stomach mucosa. This may be used for the study of the proteolytic effects of gastric juice in the laboratory. By allowing gastric juice to stand for a day in the ice chest the pepsin is precipitated, which may also be used experimentally in the same way as the extracts. The chemical nature of pepsin is unknown.

**Stomach Absorption.**—There is comparatively little absorption in the stomach—small amounts of water, salts, sugars, and dextrins, albuminoids, peptones and proteoses, and certain substances in solution, such as some drugs and alcohol.

**OSTEOPATHIC LESIONS AND GASTRIC DIGESTION.**

We have shown that upper dorsal lesions in dogs cause a variation in gastric secretion and digestion. Dr. McConnell has also found similar results. It has further been shown that pathological changes result from osteopathic lesions. By the term "pathological changes" is meant the perversion of normal structure which renders it impossible for the structure involved to perform its normal function. There is experimental evidence to bear out the statement that dorsal lesions produce pathological lesions in the stomach.

Dr. McConnell has experimented on a great many animals in this way. First he determines that the animal is normal in every way and then produces artificial bony lesions, in this case in the dorsal region of the spine. The animal is carefully observed daily for from ten to thirty days and after this length of time it is killed and a thorough post-mortem examination made, including careful examination of the stomach walls. The tissues are placed in a fixing fluid and then made into sections. These sections are stained and examined under the microscope, and it has been determined from the examination of a great many animals that actual changes of degeneration occur in the walls of the stomach. In our own research work we have confirmed these findings. The explanation of this is that the osteopathic lesion interferes with the normal function of the structures which receive their innervation from the segment of the spine involved by the spinal lesion. The structures are affected in one or another of several ways; nutrition (trophism) is cut off or reduced and the structure to some extent degenerates. It loses the power of performing its normal physiological functions and by virtue of its vaso-constrictor nerve supply, which is also interfered with, it has not the power of regulating the blood supply and venous drainage and in this way and by involvement of the secretory nerves the secretions are rendered abnormal. They are deficient in amount, deficient in enzyme content and these are the probable causes of the decreased digestive ability of the stomach resulting from bony lesions. It

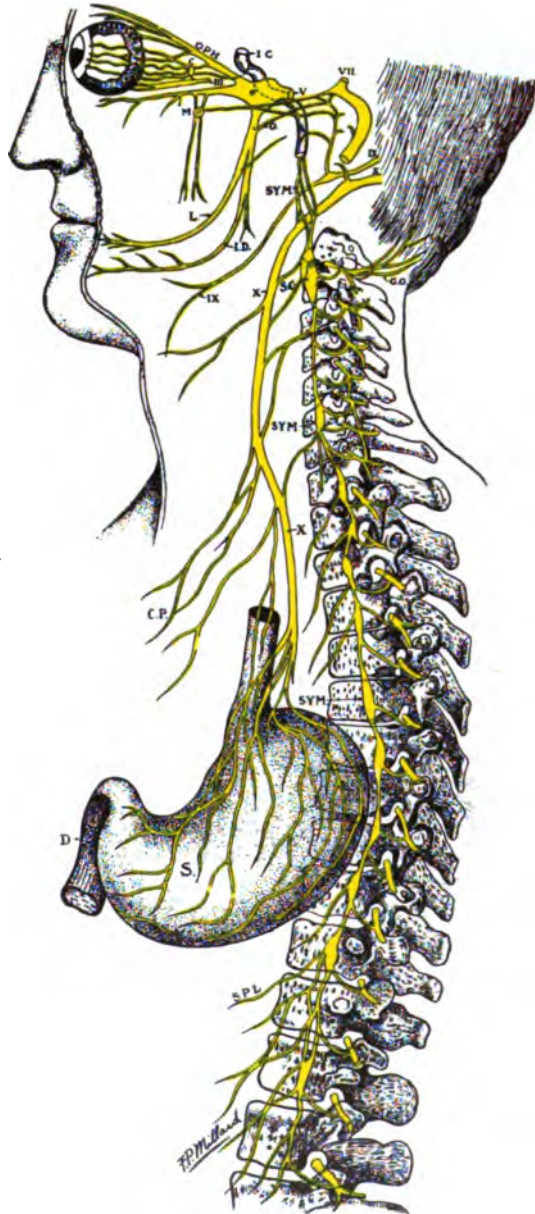

PLATE XIII.—S, Stomach and its nerve supply from the pneumogastric (X). Note the close connection between this nerve and the nerves of the head, making it easy for stomach troubles to cause headaches. D, Duodenum; III, motor oculi; V, trifacial; VII, facial; IX, glosso-pharyngeal; X, pneumogastric; Sym, sympathetic nerve chain running down the front of the spinal column and connecting with the spinal nerves as well as the pneumogastric and splanchnics (Spl.) to the bowels; C P, cardiac plexus of nerves going to the heart; S C, superior cervical ganglion of the sympathetic; Oph, ophthalmic division of trifacial; C, ciliary ganglion; M, Meckel's ganglion; O, otic ganglion; L, lingual nerve; I D, inferior dental; G. O, great occipital nerve.





may be argued that since the vagi are the chief secretory nerves to the stomach, dorsal lesions would not be responsible for the perversion of gastric functions; but as has been given above, an important part of the stomach secretion is due to normal functions of the stomach walls producing internal secretions, which continue the secretion of gastric juice; and whether the splanchnics are secretory or not, they are certainly essential in that they have much to do with the regulation of the blood supply and nutrition to the walls of the stomach and its glands from which the secretion comes.

## CHAPTER XVI.

# SECRETION AND DIGESTION IN THE INTESTINES.

**General Statement.**—Products of gastric digestion are received at intervals into the duodenum where they are further digested by the secretions of the pancreas, liver, and duodenum. The internal secretions of these structures are to be discussed later.

**The Pancreas** produces three well-known enzymes which perform essential functions in intestinal digestion. They are amylopsin, a pancreatic diastase; an amylolytic enzyme, trypsin, a proteolytic enzyme, and steapsin or lipase, which is a lypolytic enzyme. This organ is a long glandular structure which empties its secretion through the pancreatic duct (duct of Wirsung) into the midportion of the duodenum in common with the bile duct.

**Methods of Study.**—A permanent fistula of the pancreatic duct may be made by attaching a part of the wall of the duodenum containing the duct of Wirsung to the abdominal wall. Pure pancreatic fluid for experimental study can be collected in this way.

Another method by means of which the secretion of the pancreas is studied experimentally consists in the injection of certain substances intravenously. Secretin, an extract of the wall of the duodenum, when injected into the blood stream causes an excessive flow of pancreatic juice. The injection of pilocarpin into the veins also causes a flow of pancreatic juice, but because this drug has an influence on other structures, the product obtained differs so much from normal pancreatic juice that the results are not dependable.

**Secretory Nerves.**—That the vagus is secretory to the pancreas may be shown by the stimulation of its peripheral end

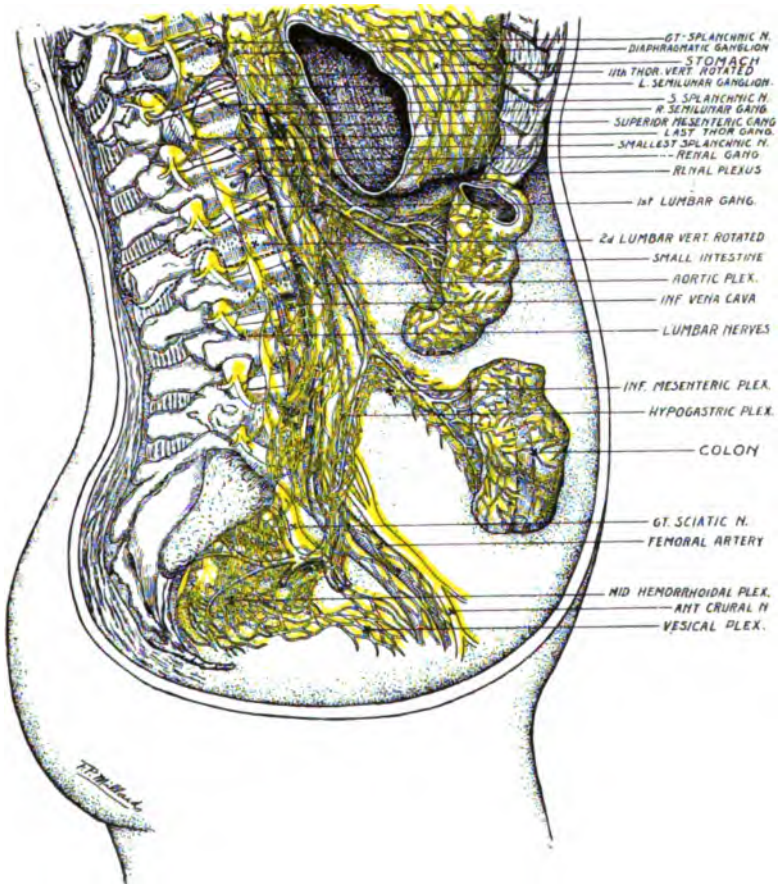

**PLATE XIV.**—Showing the lower part of the spine and pelvic region, with spinal and sympathetic nerves to the organs in the abdomen and pelvis. The pelvic organs have been omitted, but the sympathetic nerves are shown, which supply and control these organs. Notice the two lesions at the 11th dorsal and 2nd lumbar, which might influence the functions of the spinal nerves as they leave the spinal column, also the sympathetic chain throughout its close connection with the rami.



after a degeneration of the cardio-inhibitory fibers. (Pawlow.) The secretion of pancreatic juice by the vagus is probably regulated reflexly from a secretory center in the medulla similar to the secretory mechanism of the salivary and gastric glands.

Any decrease in blood supply materially affects the function of the pancreas; therefore any interference with the normal regularity of heart beat or blood pressure varies the secretion of this structure.

The spinal autonomies or splanchnic nerves also play an important part in the secretory functions of the pancreas. (Pawlow.) It has been shown that zymogen granules are stored up in the gland during rest. This we may reasonably assume to be a trophic effect of these nerves very similar to the changes which are known to occur in the salivary glands. Microscopic and macroscopic changes have been noted during activity of the glands. The vagi probably cause the discharge of this zymogen material and the active flow of the secretion.

Hormones (or pancreatic secretin) produced by the mucous membrane of the duodenum when stimulated by the acid gastric secretions, cause an excessive flow of pancreatic juice. (Bayliss and Starling.) This stimulation of flow seems to be caused at regular intervals as each new quantity of acid chyme is passed into the duodenum from the stomach. There are certain substances present in the secretions of the duodenum which seem to have the power of activating pancreatic juice. They are called by Pawlow "ferments of ferments." This explanation has been questioned but is generally accepted. Bayliss and Starling have shown that "the smallest quantity of enterokinase is sufficient to activate any amount of trypsinogen if sufficient time be allowed" (Starling), which is evidence against the composite nature of trypsin from trypsinogen and certain secretions of the duodenum. There are many chemical substances such as lime salts, etc., which have the power of activating pancreatic juice, but the nature of such action is not at all understood. The secretion begins a few minutes after eating and continues two or three hours. There is probably no flow of pancreatic juice while the stomach and duo-

denum are inactive. Like the secretion of gastric juice, we may conclude that pancreatic juice is produced by two common causes: First, the action of secretory nerves, the splanchnics acting trophically in the formation of zymogen granules (trypsinogen) and the vagi causing their discharge; second, the continuation of the secretion by hormone action.

**Protein Digestion.**—Pancreatic juice when collected in a pure state from the duct has no action on proteins. The trypsinogen or forerunner of the proteolytic enzyme is reduced to trypsin by the action of enterokinase, which is a constituent of succus entericus secreted in the walls of the duodenum. When trypsinogen is so activated by enterokinase it is changed into a very active proteolytic enzyme, trypsin, which effects a very thorough digestion of the proteins that have passed partly digested from the stomach. These protein bodies, the peptones, albuminoses, etc., are further digested into amino-acid compounds and other end products. Trypsin acts best in a neutral or slightly alkaline medium. End products of tryptic digestion such as amino-acid compounds interfere with further digestion, but if these end products are removed, digestion continues.

Milk when acted upon by pancreatic juice is coagulated, the clot being readily proteolyzed. This may be the result of trypsin or a separate rennin ferment of the pancreatic juice.

Carbohydrates are reduced by an amylolytic enzyme of the pancreatic juice known as amylase or amylopsin. It quickly reduces starch to erythrodextrin and maltose, which action is similar to that of ptyalin. This action of hydrolysis continues until dextrose and glucose are formed, and again, like the action of saliva, it is another enzyme—maltase—which effects this latter reduction to the monosaccharids. This enzyme has no invertase and therefore there is no action on milk sugar or cane sugar.

**Fat Digestion** in the duodenum is effected by the combined action of bile and lipase of the pancreatic juice, which reduces the neutral fats to glycerine and fatty acids. The enzyme is active in slightly acid, neutral or alkaline media. Saponification results if the reaction is alkaline. The bile salts assist in breaking down

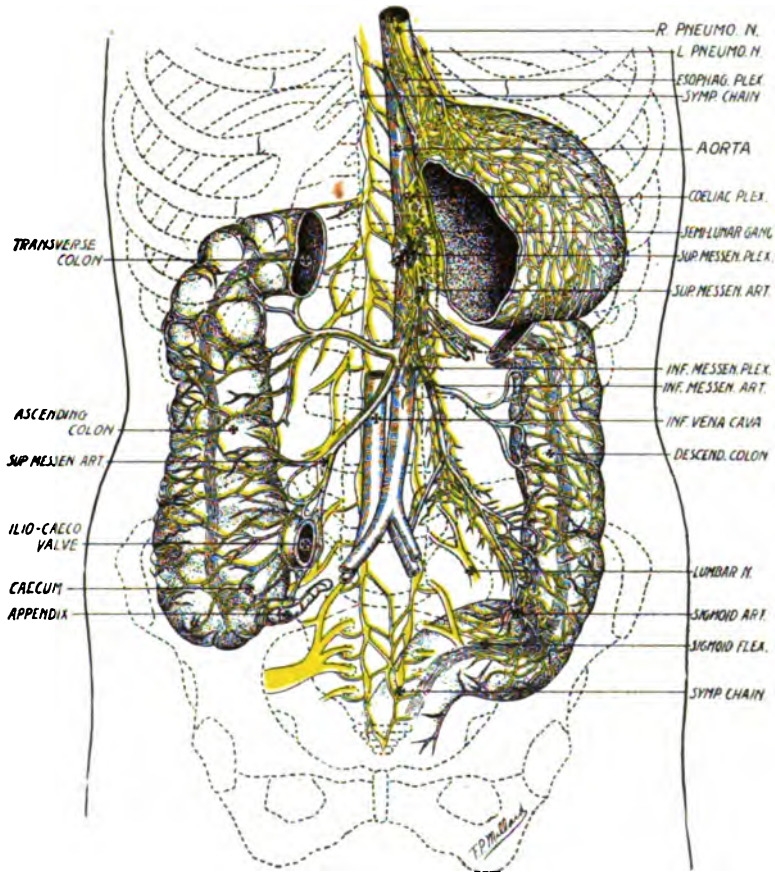

**PLATE XV.**—This cut shows the stomach and a portion of the intestines with their nerve and blood supply. The stomach is also shown in a prolapsed condition, as indicated by the dotted outline. The sympathetic chain and its connection with the pneumogastric is shown in relation to the walls of the stomach.



the  
effe  
acic

juic  
alk  
.50  
ce  
to  
fo  
an  
a

t

the emulsion of fats, thereby allowing the enzyme to be more effective and furnishing a better solvent for the enzyme. Bile acids also assist in dissolving the soaps and fatty acids.

**General Properties of Pancreatic Juice.**—Pancreatic juice is a clear, opalescent fluid, alkaline in reaction from the alkaline carbonates; has a specific gravity of 1.007; contains about .5% protein. The amount of secretion is from 500 to 800 cubic centimeters daily. There is inconclusive experimental evidence to show that the quality of the secretion varies with the kind of food given, an excess of protein producing a juice richer in trypsin, and an excess of carbohydrate results in a juice which is richer in amylopsin.

**Secretions of the Intestine.**—The tubular glands known as the crypts of Lieberkuhn produce a secretion—succus entericus—which is alkaline in reaction, due to sodium carbonate. Its value as a digestive secretion is questionable.

Substances which may be found in extracts made from the walls of the intestines contain the following enzymes: Erepsin, a proteolytic enzyme which causes a further hydrolysis of peptones, proteoses, and so on; invertase, which reduces disaccharids to monosaccharids; nuclease, which reduces nucleins and nucleic acids, and the secretins or hormones as given above.

The greater part of the secretion of the intestines is produced in the upper part of the small intestine. The colon secretes an alkaline mucous fluid, but there are no known enzymes produced in the large gut. There is probably some digestion continued in the large intestine from the action of the enzymes produced higher in the canal. The causes which regulate secretion of the intestinal glands are not well understood. It is highly probable that both the vagi and splanchnic nerves have at least a regulating effect on these secretions, and that the presence of food, especially when it contains pancreatic juice, excites these glands to activity. The secretion of these glands, therefore, may be regulated, to some extent at least, by hormone action.

There seems to be a substance, an anti-enzyme, produced in the stomach and intestines which inhibits the action of proteolytic

enzymes at the end of the digestive process, and the walls of the viscera are thus protected from the activity of these enzymes. The neutral or slightly alkaline reaction of the blood also prevents this activity.

**The Liver.**—Bile, the external secretion of the liver, is temporarily stored in the gall bladder, from which it is emptied into the duodenum during digestion through the common bile duct. The combined action of bile and pancreatic lipase on fats has already been given. Bile in some respects is also an excretion. As an excretion the coloring matter of the blood hemoglobin, is constantly being thrown off. The gall bladder serves the double function of receptacle of such excretions and retainer of the bile, which must be stored and discharged when needed for digestive processes. Certain changes occur in the bile while it is contained in the gall bladder. It is concentrated by the loss of water and gains some mucin and nucleo-albumin, which are formed from the lining cells of the gall bladder.

**Constituents and Properties of Bile.**—(Hoppe-Seyler, from Starling's physiology.) Mucin, 1.29%; sodium taurocholate, 0.87%; sodium glycocholate, 3.03%; soaps, 1.39%; cholesterin, 0.35%; lecithin, 0.53%; fats, 0.73%. The most important of these constituents so far as digestion is concerned are the bile salts and bile acids.

Secretory nerves to the liver have not been demonstrated. Stewart states: "Of the direct influence of nerves, either on the secretion of bile or on its expulsion, we have scarcely any knowledge, scarcely even any guess which is worth mentioning here." It is generally considered that the secretion of bile varies directly with the blood supply to the liver; and because the spinal autonemics are vaso-constrictors to this organ, stimulation to the peripheral end of the splanchnics or the central end of the sensory or fixed nerve leading into the cord should, and according to most authorities does, decrease the flow of bile.

**Methods of Study.**—The Pawlow fistula is made by attaching a section of the duodenal wall containing the opening of the gall duct into the abdominal wall so that the fluid may be collected

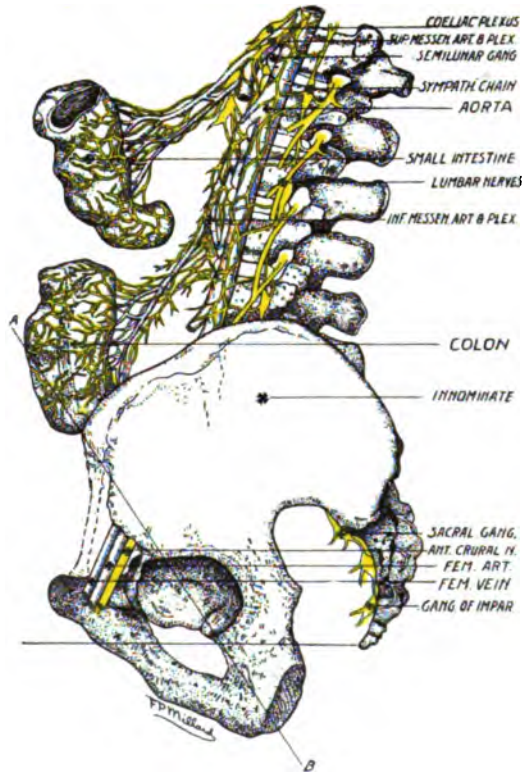

**PLATE XVI.** —Showing the blood and nerve supply to sections of small intestine and colon. Note that the fibers of the splanchnic nerves are distributed with the blood vessels supplying the gut. Note, also, the connections with the lateral chain ganglia.



externally. The common bile duct may be cannulated through an opening in the abdominal wall and the fluid collected in this way, or a cannula may be placed into the duct leading from the liver in order that the fluid may be collected before it reaches the gall bladder.

**Secretion of Bile.**—Like pancreatic juice, the secretion starts soon after eating and continues for from two to four hours, the amount of secretion varying from 700 to 800 cubic centimeters daily. The greatest flow occurs at the height of intestinal digestion, which is about three hours after eating.

**Causes of Secretion.**—The secretion of bile by the liver is a continuous process, but the amount is increased during digestion. Starling holds that the secretion of bile is effected by a hormone—secretin—probably in the same way that the pancreas is excited to activity. He states: "In one experiment, for instance, the injection into the veins of five cubic centimeters of a solution of secretin, prepared in this way, increased the secretion of bile by the liver from twenty-seven drops in fifteen minutes to fifty-four drops in fifteen minutes. The rate of secretion was therefore doubled." Scott and Wendorff, working in the laboratories of the American School of Osteopathy, have by osteopathic stimulation of the mid-dorsal region increased the rate of flow from forty-nine drops in fifteen minutes to seventy-five drops in fifteen minutes.

**Effect of Various Foods.**—The greatest flow of bile results from meat diet, while a meal of carbohydrates causes little bile to be discharged.

Cholagogues are those substances which have the power of exciting the liver to increased secretional activity. Numerous drugs have been tried, but the various observers differ very widely in their findings. Stewart states that: "The only real cholagogues at present positively known appear to be the salts of the bile acids, which, given by themselves or in the bile, cause not only an increase in the volume of biliary secretion, but also an increase in its solids." The liver then produces its own cholagogue, and since its secretion varies directly with the blood supply to the

gland, we can readily see the value of maintaining a normal nerve supply, since secretory nerves to the liver have not been demonstrated.

The gall bladder is a sacculated diverticulum of the gall ducts containing smooth muscle, the contraction of which causes a discharge of its contents. Its opening into the gall duct is guarded by a sphincter valve, which structure also regulates the discharge of the contents of the bladder. The nerve supply of the gall bladder comes from the vagi and splanchnics, and both pathways probably contain motor and sensory fibers. The chief function of the splanchnic fibers seems to be constriction of the bladder and dilation of the duct, while the chief function of the vagal fibers is opposite to this. There is little definite information to be had on this subject. The discharge of the bile by constriction of the bladder and dilation of its sphincter is effected by the presence of acid chyme in the duodenum. A flow is caused by each discharge of chyme from the stomach into the duodenum. Whether the mechanism is a reflex by way of afferent and efferent fibers in the spinal autonomies, or whether the discharge is caused by a hormone or secretin, as in the case of pancreatic juice, has not been determined. Probably both factors play important parts in the regulation of its flow.

**Functions of the Liver.**—Besides the functions which have been given, the liver has others: An important internal secretion which will be discussed later, and the removal from the system of certain waste products of metabolism, such as cholesterin, lecithin, bile pigments and bile acids. The bile acids are end products of liver-cell metabolism of proteins. The bile pigments and bile acids are probably reabsorbed to a certain extent, and are therefore not wholly excreted.

Bile is slightly antiseptic and tends to prevent bacterial putrefaction. Another important function of the liver is the formation of glycogen. Glycogen or animal starch ( $C_6H_{10}O_5$ )<sub>n</sub> is reduced by ptyalin to maltose and dextrin, like other starches. The liver furnishes a storehouse for the digested starch, and from twelve to fourteen hours after a meal of

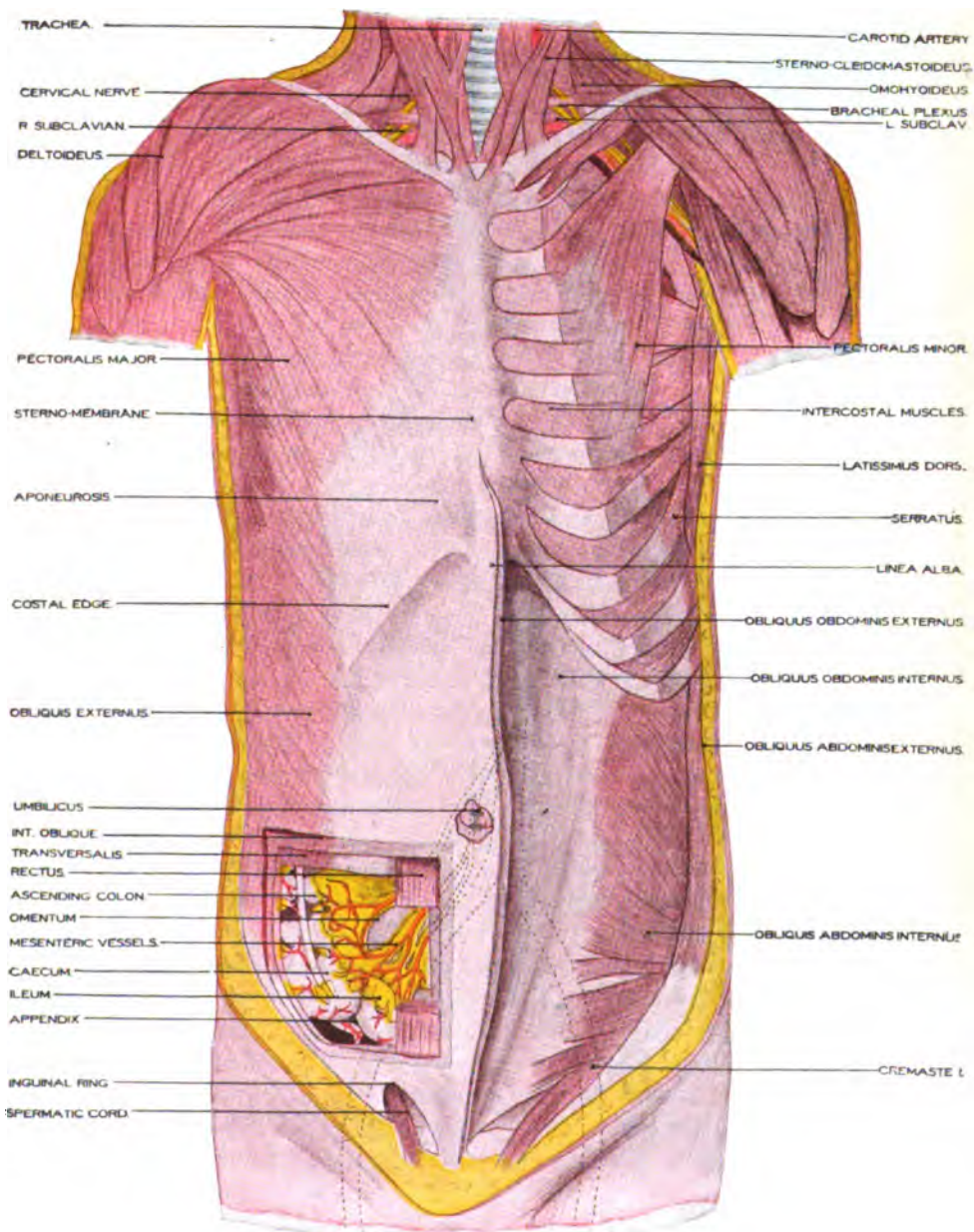

PLATE XVII.—Abdominal muscles removed, showing topographical position of the ascending colon, its blood supply, and its relation to the adjacent viscera.





carbohydrates it may be found in the liver in great quantities. (10% to 12% of the total weight of the liver.) The quantity of glycogen in the liver varies materially with the nature of the diet used—from 1-2% to 12%. The greater part of the carbohydrate food stuffs reaches the liver in the form of dextrose and levulose, where they are converted by a process of dehydration into glycogen. Certain end products of protein foods are also converted into glycogen synthetically in the liver, and protein substances are to some extent glycogen formers. Whether fats may be converted into glycogen is yet a moot question, but there is good experimental evidence to show that certain end products of fat digestion, glycerine for example, may be changed to glycogen, but, if at all, a very small percentage of glycogen is so formed from fats.

The functions of glycogen formation are not fully understood. The most probable purpose is the storage of carbohydrate materials for future use. The liver furnishes in this way a reserve supply for the system between meals. Carbohydrate foods are absorbed from the intestine during digestion and are carried to the liver by way of the portal vein in the form of dextrose, levulose and galactose, and the change to glycogen is effected by the liver cells where it is stored. Were it not so changed the sugar content of the blood would be materially increased, which condition does not occur in normal individuals. The normal sugar content of the blood being at all times from 0.1% to 0.2%, any increase in this amount is pathological (the condition being known as hyperglycemia) and the excess is thrown off by the kidneys, causing glycosuria, or sugar in the urine, which is a common condition in diabetes mellitus, a disease resulting from an inability of the system to store and metabolize its carbohydrate material. The liver, however, is limited in its ability to form and store glycogen, and if carbohydrates are eaten in excess or a large quantity of sugar is ingested, a temporary or alimentary glycosuria results.

After a time the glycogen of the liver is reconverted into dextrose. It is carried from the liver in the form of sugar and re-stored in resting muscle in the form of glycogen, where it fur-

nishes the chief source of energy for muscle activity. Glycogen is also stored in leucocytes, in the placenta, in various tissues of the embryo, and in many other tissues. The glycogen content of muscle is rapidly reduced by muscular exercise, and as the muscle depends upon the liver for its reserve supply, the glycogen content of this organ is also reduced by muscular activity. Starvation also reduces the glycogen body content.

Another function of the liver is that of urea formation, which is affected by the liver cells. The former theory of the production of urea in the kidneys is now generally abandoned.

### **OSTEOPATHIC CONSIDERATIONS.**

It is not surprising that the many attempts made by workers in general physiology have so far failed to demonstrate the functions of the nerve supply to the liver as well as the influence of the nerves to many other secreting glands. The methods in common use by most mammalian experimenters are enough in themselves to defeat their purposes. The stimulation, for example, of nerve trunks by artificial methods is a very unsatisfactory procedure and can surely not always be relied upon as giving satisfactory results. As has been explained above, the stimulation of the peripheral end of the vagus does not always produce secretion in the stomach glands, and when it does the stimulus is followed first by a period of latency during which time there is no secretion. It is definitely known that the vagus is secretory to the stomach and that the taking of food into the mouth is quickly followed by secretion. Why, then, does the direct stimulation not cause secretion? It is probably because of the inefficient methods used, overstimulation or something of that nature. The same explanation probably holds good for the liver, pancreas, and other secretory glands, and the fact that secretory nerves to the liver have not been demonstrated is of no great significance.

In our research work on the liver we have quite conclusively shown (see Series No. 17, Part II) that osteopathic stimulation

applied to the seventh, eighth, and ninth thoracic region produces an increase in the secretion of bile from 25% to 100% and that this flow continues for some time. According to the theory of secretion of the liver being due to an increased blood supply and that only, stimulation of this region should cause a decrease of secretion according to the theory stated in general physiology, as the splanchnic fibers are supposed to be vaso-constrictors and would thus decrease the blood supply to that gland. The work on this series has been done so carefully that there seems to be no possible doubt of the result, and we must therefore attribute the excessive secretion following such stimulation to specific secretory nerves or to vaso-dilator effects. It seems reasonable to accept the theory of secretory or trophic nerves.

The fact that workers in general physiology have failed to demonstrate secretory functions in these nerves is of no particular significance, as they have never used methods which would demonstrate the normal functions of these nerves. Direct stimulation of the peripheral ends of these nerves, or artificial stimulation of the cord segments from which these fibers originate, are inadequate for the determination of the normal functions originated normally by the cell centers and propagated to the structures supplied by uninterrupted paths of conduction. Osteopathic treatment (it may properly be called stimulation), surely accomplishes the results. These are not recognized by other experimenters, and will never be discovered by other workers until they have developed entirely new methods of experimentation. The reader, therefore, need not be surprised that our results differ widely from those of other physiological experimenters. To summarize, then, we may say that from the results of our work we must conclude that the liver is a gland of secretion and excretion, that the spinal autonomic nerves which supply it are secretory and trophic as well as vaso-motor, and that the functions of this organ can be materially influenced by osteopathic treatment; that if a bony or other structural lesion exists anywhere which offers obstruction to the normal passage of impulses by way of the nerves, or if such lesion interferes with the normal arterial

supply to the segments of the cord within which the cell bodies of these nerves lie, or if the venous or lymphatic drainage from these segments be obstructed, or if the pathways of the afferent impulses to these segments be interrupted, surely the normal functions of this organ will be impaired.

The liver produces its own cholagogues, which are sufficient for its own regulation of function. Given a normal nerve and blood supply, this organ will by the production of its own cholagogues perform more nearly its normal functions than can be hoped for by artificial means.

It is well known that the liver, pancreas, and duodenum bear certain essential functional relations to each other. The duodenum produces secretions which to some extent, at least, regulate the functional activity of the liver and pancreas. These three structures may well be termed the splanchnic triad, and since the stomach is also regulated by the secretions of the duodenum that organ may also be classed as a member of this functional unit. Physiologists are too prone to neglect the functions of these structures as a unit and ascribe too much independence to each. It is highly essential that the student of osteopathy realize the close relationships existing between different structures and consider his therapeutic methods accordingly. If, for example, a vertebral lesion is found which may influence one of these structures it would be very unscientific to treat that one lesion and neglect others which might be affecting the functions of another of this functional triad.

**Intestinal Absorption.**—Absorption from the intestines occurs by way of two routes. It may be taken into the blood stream directly, being taken up by the capillaries of the villi, or it may be taken up by the lacteals of the villi and carried into the thoracic duct, which finally empties it into the blood stream.

Absorption occurs rapidly, especially in the small intestine, where the greater amount of the end products of digestion are taken up, the fats going by way of the lymph vessels and the greater part of the other food products by way of the blood stream to the liver. Some foods are sufficiently digested to reach the

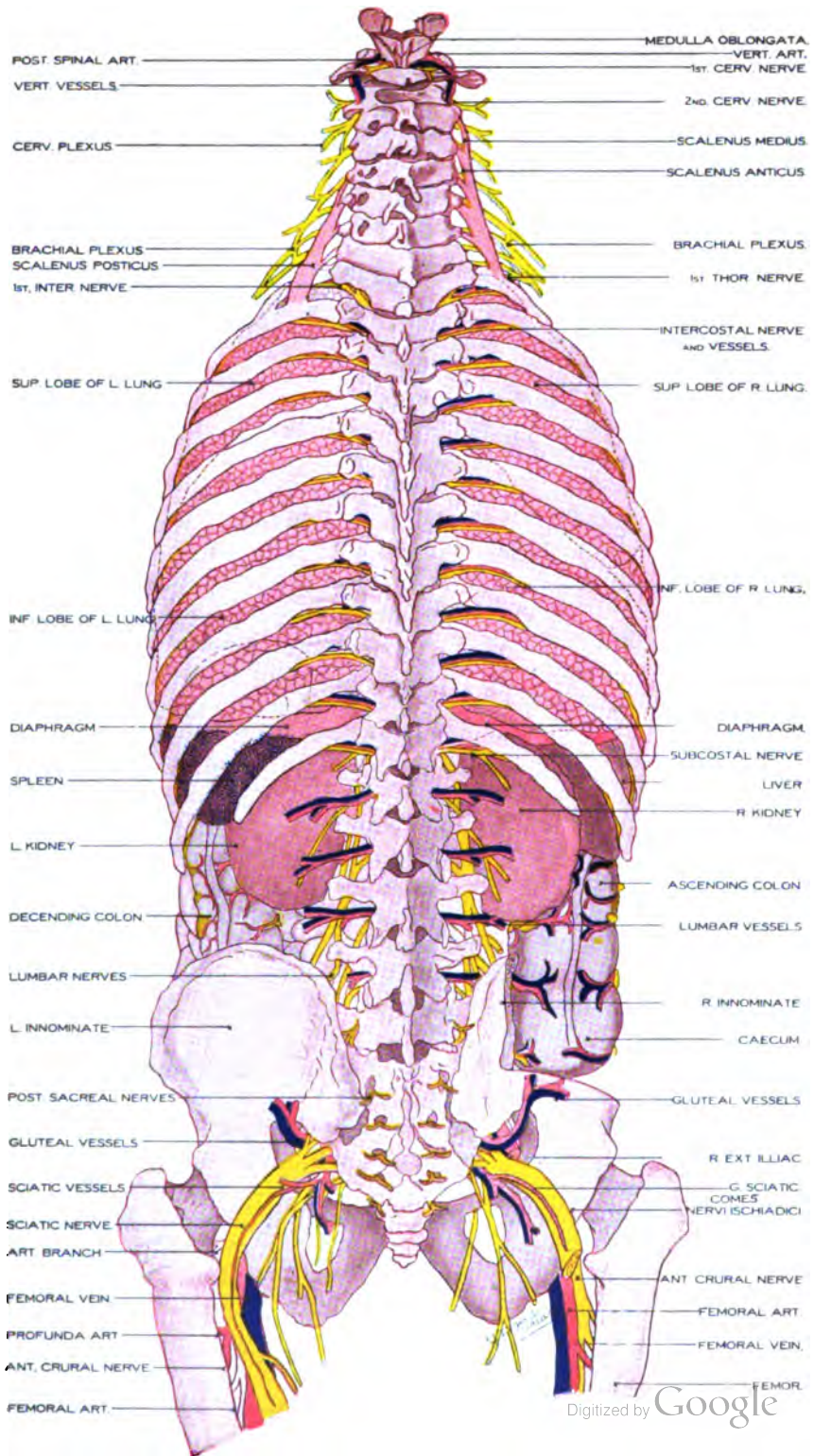

PLATE XVIII.—Innominate cut away, showing position of the ascending colon in its relation to the right kidney, liver, and lumbar tissues



ileo-coecal valve within two hours after ingestion, but from five to twenty hours is required for the entire meal to pass into the colon.

The mechanism of absorption is not clearly understood. It is reasonable to suppose from the experimental evidence at hand that absorption occurs from physical causes such as osmosis, diffusion, etc., and by a more complicated process of the activities of the living cells. Carbohydrates are mostly absorbed in the form of monosaccharids. Dextrose requires no digestion, but is directly absorbed as eaten. Starches and other carbohydrates need to be reduced, as explained above. The mechanism of fat absorption is not well understood. It may be that the fatty acids and glycerine are absorbed by the epithelial cells, or that the leucocytes lying between the cells ingest the fat droplets and in this way pass it on to the lacteals. The importance of the bile and pancreatic lipase on the preparation of fats for absorption is well shown in animals with permanent fistulas of the ducts of the gall bladder and pancreas. Instead of being absorbed, the fats when fed to these animals are passed out undigested.

Protein substances are absorbed principally by the blood stream, being taken up by the capillaries of the villi, but in case of an excess of protein in the diet, some may be absorbed by the lymphatics. The chemical nature of the proteins in the blood stream or the method by means of which they are absorbed is not fully understood. The end products of protein digestion resulting from the action of the digestive enzymes of the stomach and intestines, the peptones and proteoses, are probably absorbed directly without further change. Undigested proteins are absorbed to some extent at least, in the small and large gut. The good results obtained from feeding per rectum and the fact that these substances are absorbed from ligated loops of the small intestine, conclusively prove this. The absorption of protein is greatest for the animal foods such as meats, eggs, milk, etc. (97% to 99%), while the percentage of absorption of the vegetable proteins is much lower, probably not more than 70% or 80%.



The functions of the large intestine may be briefly summarized as follows: It does not produce digestive enzymes, but some digestion occurs from the action of the enzymes passed on from the stomach and small intestines. It secretes some mucous and absorbs a much greater quantity of water from its contents than is secreted by its walls, and thus reduces the intestinal contents to a more solid mass, which moves very slowly through the colon, and by constant absorption of water it is formed into feces, which differ in amount and composition according to the nature of the food taken and the completeness of digestion and absorption. When a meat diet is given, the quantity is smaller and darker in color than when a mixed diet is ingested. The quantity is greatest on a vegetable diet, especially when foods rich in cellulose are taken. The average individual living on a mixed diet excretes from 150 to 200 grams of feces daily. Feces consist of the undigestible substances in foods, such as ligaments, cellulose and undigested foods, some starches, proteins and fats, and excretions such as cholesterin, mucin, epithelial scales, pigments, salts, and products of bacterial fermentation. The odor is due to certain chemical substances, such as phenol, skatol, and products of bacterial putrefaction, hydrogen sulphide, etc.

Bacterial fermentation occurs under certain conditions in various segments of the alimentary canal. It has never been positively demonstrated that bacteria are absolutely necessary to normal digestion, but on the other hand certain bacteria perform functions which are not at all harmful, and in some instances seem to play important parts in digestion, such as the lactic-acid producing bacteria, *bacillus bulgaricus*, etc. The function of bacterial fermentation in the stomach has been given. Certain kinds of bacteria are normally present in the small and large intestines. In the small intestines carbohydrate-fermenting bacteria seem to perform essential functions, and those that ferment proteins are also slightly effective, but their action is inhibited by the organic acids, such as acetic and lactic acids. Since the reaction in the large intestine is normally alkaline (Howell), the environment is favorable to bacterial fermentation,

which is an almost constant process. Putrefactive fermentation in the colon reduces proteins, carbohydrates and cellulose, forming various organic and inorganic end products, some of which have been named. That a certain amount of putrefactive fermentation is normal in the colon cannot be questioned, but if for any reason this process is excessive, abnormal irritation of the intestinal mucosa results, causing diarrhea, or by the formation of toxins, may cause various systemic disorders from auto-intoxication. The function of *B. bulgaricus* of Metschnikoff will be found in works on bacteriology. Suffice it to say here that we believe Metschnikoff's theory of the great detriment of other bacteria in the colon is probably very much overestimated.

## CHAPTER XVII.

# MOVEMENTS OF THE STOMACH AND INTESTINES.

The alimentary tube consists in general of essentially the same layers throughout. A mucous layer within, usually a serous or protective layer on the outside, and a muscular layer between the other two, which consists of two coats—circular and longitudinal fibers—with the exception of the stomach, where a third coat consisting of the oblique fibers, is found.

**The Stomach.**—The stomach is an enlarged portion of the tube which is structurally modified for the performance of certain functions. As Dr. A. T. Still puts it, it is the “mortar box” for the retention and mixing of the foods for other workers. The stomach consists of certain modified parts, as follows: The

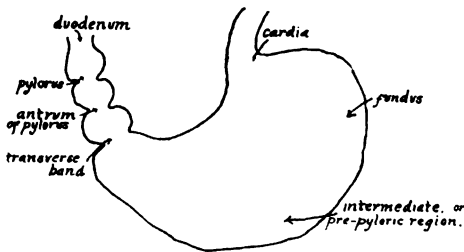
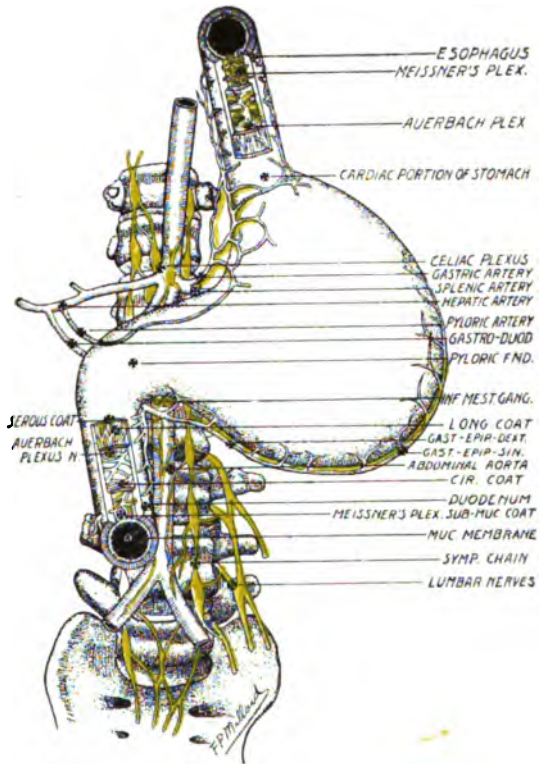

FIG. 20.—Showing the general outline of the stomach with its different parts. (After Retsius, taken from Howell.)

fundus is the large cardiac end lying to the left of the œsophageal opening; the intermediate or pre-pyloric portion, which lies between the fundus and the antrum or pyloric portion; the intermediate portion and antrum are separated by the transverse band, which consists of an excessive number of circular fibers and functionally is a modified sphincter, at which point the essential movements of peristalsis of the stomach begin. The fundus serves chiefly as a receptor for the food stuffs. The body or intermediate portion is the chief secreting part, producing the greater amount of hydro-



**PLATE XIX.**—This cut represents the stomach with the esophagus emptying into it, and the duodenum (first part of the small intestine) leaving it. The different layers are shown so that the muscular walls of the stomach may be explained, also the nerve and blood supply of the walls.



chloric acid and gastric juice, and the antrum constitutes the chief motor part, in which by peristalsis the stomach contents are forced to and through the pylorus into the duodenum.

The stomach wall consists of the following layers: The innermost layer is the mucous, below which is the submucous, containing the secreting glands; the muscular layers are next, consisting

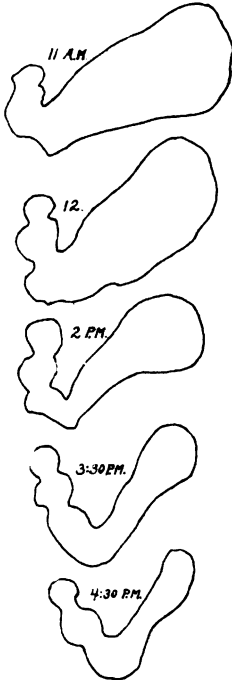

FIG. 21.\*

of three layers of fibers, the innermost and least distinct of which is the oblique layer; the circular or middle layer is continuous from the cardiac sphincter to the pyloric sphincter, and is of greatest functional importance in the antrum; the longitudinal or outermost layer is continuous from the œsophagus to the duodenum. As has been stated above, the fundus serves as a reservoir for the food stuffs, and therefore its muscular activity is very limited. The solid food of a meal often lies in the fundus for several hours, during which time the active antrum is throwing off the digested portions from the mid-stomach.

**Methods of Study.**—The famous observations of Beaumont on St. Martin, who from a gunshot wound had a permanent opening in the stomach, yielded important data, but the reliable information that has since been added by Cannon, who has studied these movements of the stomach by means of the X-rays, is now recognized by all. By mixing food with bismuth subnitrate, a good medium may be formed for producing Roentgen-ray effect. Photographs of the animal's stomach while digesting food are made and the movements determined in this way. The stomach of an

\*FIG. 21.—This figure shows movements of the stomach as recorded by Dr. Cannon by means of his notable X-ray study. This series shows the progressive changes in the form of the stomach of a cat taken at various periods after a meal. The meal was given in this case at ten o'clock A. M.

animal may also be observed directly by exposing the stomach through an incision in the median line of the abdomen and covering the viscera with warm normal salt solution to prevent shock from exposure to air.

**Results.**—The movements of the stomach may be grouped into three classes, all of which are simply peristaltic in nature: First, peristaltic waves beginning at the transverse band and extending over the antrum to the pylorus. These movements

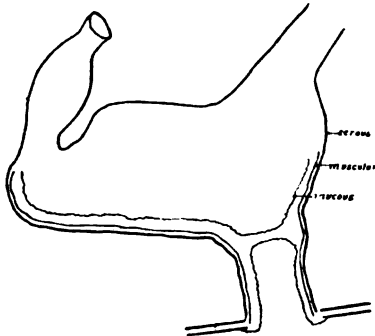

FIG. 22.\*

increase in amplitude as digestion progresses, serving to triturate and mix the food with the secretions, and tend to force the contents through the pylorus.

These movements usually begin a few minutes after food enters the stomach. Second, other waves of lesser amplitude begin at rather regular intervals (every twenty seconds) in the mid-portion of the stomach and

move towards the pylorus. Third, occasionally slight peristaltic waves may be seen beginning at the fundus and extending towards the pylorus, but these waves are not so great in amplitude as the waves of the antrum.

**Movements of the Small Intestine.**—The various coats of the intestine are the same as those of the stomach, except that the oblique muscular layer is lacking. The movements of the intestine consist of a simple peristalsis, a relaxation followed by a constriction, which movement in the form of a progressive wave moves from the pylorus to the ileo-cæcal valve. This peristaltic wave—the dilation followed by constriction—is explained by Bayliss and Starling as being due to the intrinsic nerves, since

\*FIG. 22.—This figure shows Pawlow's method of preparing an artificial stomach for the collection of gastric juice free from food substances. The lower part or small stomach has been prepared by surgically separating a portion of the stomach in such a way that the secretion of gastric juice may be continued, but the contents of this small stomach do not in any way come in relation with the contents of the stomach proper. The small stomach is connected to the abdominal wall in such a way that the pure gastric juice as secreted may be drawn off for the purposes of study.

section of the extrinsic nerves does not prevent the movement, but the painting of the gut with nicotine or cocaine, which stops the action of the intrinsic nerves, abolishes the wave. "They must therefore be ascribed to the local nervous system contained in Auerbach's plexus, which we can regard as a lowly organized nervous system with practically one reaction, viz., that formulated above as the 'law of the intestines'." (Starling.) According to this authority, anti-peristalsis — a peristalsis moving stomachward—never occurs under normal conditions in the small intestines. The function of normal peristalsis is to force intestinal contents slowly through the alimentary canal.

There is another, the so-called pendular movement of the small intestine, which consists of a series of contractions locally. These are rhythmical and occur in those parts of the tube containing the food material. The effect of these movements is the division of the intestinal content into small masses, that it may better be mixed with the digestive juices.

Peristaltic waves and segmental contractions do not occur at the same time; that is, one does not interfere with the other, but a peristaltic wave may from time to time move the mass of the intestinal contents farther along, where it is again stopped and redivided by the action of the segmental movements.

**Movements of the Colon.**—The movements of the large intestine are very similar to those in the small gut, except that the peristaltic waves are less frequent and there is therefore a slower progress of their contents. "The law of the intestines," viz., the peristaltic wave of dilation and constriction, holds good in the colon as well as in the small intestines. (Starling.) Cannon holds that there is frequently and normally an anti-peristalsis occurring in the ascending and transverse colon, while in the descending colon the movement is always peristaltic toward the rectum. The views of these authorities are therefore conflicting. The function of such a reverse peristalsis would be the retention of intestinal contents for further digestion and absorption. The contents are known to move slowly through the colon, requiring about two hours to pass from the cæcum to the hepatic flexure



and from four to five hours to pass from the cæcum to the splenic flexure.

**Nerve Supply to the Colon.**—Of the extrinsic fibers, the inhibitors to the colon, as in the case of the small intestine, come from the spinal autonemics (chiefly from the upper and mid-lumbar segments). Those supplying the rectum pass by way of the hypogastric nerve. The motor fibers to the colon, except possibly the descending colon, are furnished by the vagus; the motor fibers of the descending colon and rectum originate from the sacral autonemics (second, third and fourth), and go by way of the *nervi erigentes* to the hypogastric plexus.

### **OSTEOPATHIC LESIONS AND THEIR EFFECTS ON THE FUNCTIONS OF THE COLON.**

The chief effects of lesions on the functions of the alimentary canal in general are discussed elsewhere in this chapter. It has been demonstrated that osteopathic lesions, whether occurring incidentally or produced artificially, most positively do interfere with normal movements of the gut, and in some cases seem to result in anti-peristalsis from reflex stimulation. (See p. 171.) As has been stated above, anti-peristalsis is not normal to the small intestine, and only occurs under abnormal conditions, such as exposure, injury, etc., of the intestinal wall. Research workers in osteopathy have shown that bony lesions may be a cause of anti-peristalsis. (Robb and Deason.)

A weight of from five to eight grams is sufficient to check the progress of the forward movement of peristalsis in the intestines, and often produces excessive contractions or reverse peristalsis. The variations in pressure, then, caused by visceral lesions, faulty positions, etc., are all very important in the study of normal and abnormal conditions that influence normal intestinal movements. The reader is referred to a most excellent discussion of mechanical principles by R. K. Smith, from which I quote the following: "By the use of the sphygmomanometer with a bag in the rectum it is ascertained that the pressure in the organ with

the patient in the erect posture is about 25 m. m. of mercury. If the patient is then placed in a horizontal position this pressure is reduced to 15 m. m. If he will assume the quadruped posture this pressure entirely disappears and is replaced by a negative pressure of minus 8 m. m. The lifting of a heavy weight will increase the pressure to 100 m. m. Straining at stool will put the mercury to about 70 m. m. A cough will elevate it to about 100. The same experiments performed in the stomach show a positive pressure of from 4 m. m. during expiration and 12 during inspiration." The value of these facts in the treatment of constipation, etc., is plainly evident. The collection of excessive amounts of gas in any part of the gut naturally interferes with normal movement. The cause of the gas may be a visceral or vertebral lesion, as is explained elsewhere in this chapter.

#### **THE NERVE SUPPLY OF THE ALIMENTARY CANAL.**

The nerve supply may be divided into two general groups, the extrinsic and the intrinsic. The extrinsic nerves may be again divided into two groups, the cranial autonomies, of which the vagi are the most important, and the spinal autonomies, commonly known as the sympathetics or splanchnics, those fibers which come from the spinal cord by way of the lateral chain ganglia and the peripheral plexuses to the viscera.

The vagi are the chief nerves of visceral motion to the entire alimentary canal from the upper part of the cesophagus to the descending colon. They develop early in embryonic life and seem to follow the growing gut, and therefore supply also all of the glandular and other structures which develop from the gut, viz., the lungs, pancreas, and liver. Other than visceral motion, the vagi supply secretory, sensory, and possibly some visceroinhibitor and trophic functions to the above named structures. It is very likely that they also supply some vaso-dilator fibers to the stomach and intestines.

The spinal autonomies supply the entire alimentary canal with visceroinhibitor, sensory, some secretory and trophic fibers,

and are vaso-constrictors to the vessels of the stomach and intestines. There is some reason to believe that they may also be visceromotor to the intestines, but the inhibitory function surely predominates. The spinal autonomies appear later, ontogenetically and phylogenetically, than the vagal autonomies. They come from the neural-crest cells and migrate to the viscera by way of the anterior spinal nerves. The visceromotor cells of these fibers lie in the antero-lateral horn of the gray matter of the cord. The functions of these fibers on movements of the intestines are often influenced by psychological conditions and by stimulation of cortical areas. There is therefore probably a pathway in the cord connecting the higher brain centers with these cell bodies of the lateral horn, but this pathway from the cortex to the cell bodies has never been definitely located.

The intrinsic nerves of the alimentary canal consist of the cells and interlacing network of fibers lying within the walls of these viscera. They probably originate from neural-crest cells of the hind-brain region which have migrated by way of the embryonic vagal fibers during early embryonic life, and while the layers of the gut are being formed. They are, therefore, probably more closely associated with the vagal autonomies than with the sympathetic. They constitute the plexuses of Auerbach and Meissner, are largely independent of the effects of the extrinsic nerves and are closely associated with the normal peristaltic movements of the gut. It is a well-known fact that movements of the gut may be continued after section of the extrinsic fibers, and it is natural to suppose that these fibers are associated with such functions.

There is another factor which deserves mention here, the so-called myogenic function of smooth muscle. It has been shown by Bayliss and Starling that after the application of certain drugs to the wall of the gut, such as cocaine and nicotine, which paralyze the intrinsic fibers, the gut may still be made to contract by direct stimulation to its musculature. It is supposed that this stimulus passes from cell to cell of the muscles and thus transmits the energy. This is known as the myogenic or automatic action of the intestine.

### **SPHINCTER VALVES OF THE ALIMENTARY CANAL.**

The sphincter valve consists of an augmentation of the circular fibers of the tube, of which it forms a part. For example, at the cardiac end of the stomach there is an increase in the number of circular fibers at that point, making it possible for a greater amount of constriction in the tube. The same thing is true of the pyloric end of the stomach and the outlet of the rectum. Strictly speaking, these are not valves in the sense that we ordinarily speak of valves. They are valves in that they perform the function of valves. They are valves in the sense that they prevent the food from passing from one segment of the alimentary canal to another until the necessary amount of digestion has occurred in that part of the gut.

These valves are three in number. The cardiac, the so-called cardiac sphincter, constitutes a part of the œsophagus and makes up the part of the œsophagus at the cardiac end of the stomach. The pyloric valve is the so-called gate-keeper, which lies between the duodenum and the pyloric end of the stomach. The other one is the sphincter ani, which retains the content of the rectum until conditions are right for its discharge.

**Regulation of the Action of Sphincter Valves.**—It is necessary that the student of osteopathy understand the method by means of which the action of these valves is regulated. There is a tendency for the sphincter valve to open when a peristaltic wave in the tube has moved up to it, like for example: The peristaltic wave of swallowing in the œsophagus passes down that structure and when it gets to the cardiac sphincter the latter dilates and the contents pass into the stomach. The same occurs at the pyloric end of the stomach. When the peristaltic wave from the antrum passes to the pyloric end there is a tendency for the pylorus to open and allow the contents of the stomach to pass out. This does not always occur because it is the function of this sphincter valve to retain the contents until sufficient digestion has occurred in the stomach. The conditions involved in the regulation of the opening of the cardiac sphincter are not

known. The conditions which determine whether or not the pyloric sphincter will open or remain closed are these: First, that which is called the acid-regulating mechanism of the pylorus, which means that the pyloric sphincter will not open until the contents on the stomach side are acid in reaction. After this has been effected and the contents of the stomach have passed through the pyloric sphincter, they become alkaline in the duodenum and the pyloric sphincter will not open again until the contents which have passed through by the stomach have been made alkaline by the duodenal secretions. We must have, then, two conditions—an acid reaction on the stomach side and an alkaline reaction on the duodenal side. The exact mechanism by means of which this acid or alkaline reaction effects the opening of the duodenum is not known. It may be that the regulation is a local nerve plexus at that point. Another condition necessary for the opening of the pyloric sphincter is that it tends to open at the time the peristaltic wave from the antrum of the stomach reaches it. If other conditions are right, the pylorus opens as the peristaltic wave reaches it. It is further regulated by a local nerve plexus. Not very much is known about the mechanism of this plexus. It may be a continuance of the Auerbach and Meissner plexuses. It is highly probable that the acid and alkaline reaction effects the regulation by its action on this local nerve plexus. The pylorus is also regulated, in part at least, by the extrinsic fibers which supply it. If the vagi be cut at a point just before they enter the stomach, the animal fed and then a post-mortem examination be made of the stomach some hours afterwards, it will be found that the contents of the stomach have not passed through the pylorus, showing that in some way the vagi have a regulating effect on the pyloric sphincter. There is also good reason to believe that the splanchnics also have a regulating effect on the pylorus.

The function of the sphincter ani, as above mentioned, is that of retaining the content of the rectum until time is right for its expulsion, which is determined by the following conditions: First, the stimulation of the opening of the sphincter ani varies

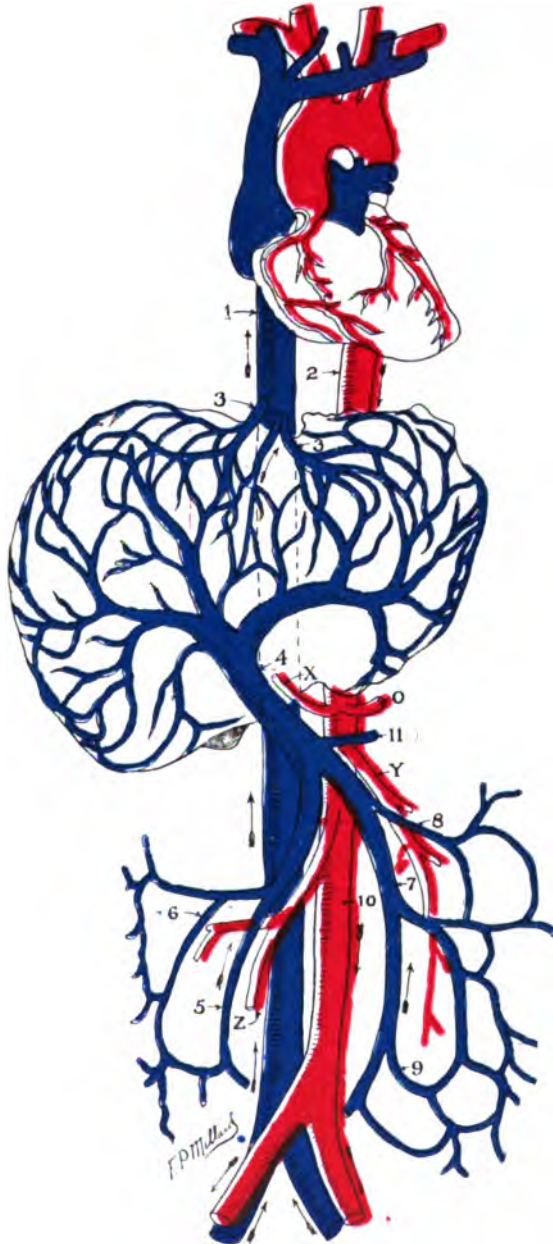

PLATE XX.—Showing the circulation to and from the heart to the liver. The blood from the heart is given off to the stomach, spleen, intestines, etc., by branches (X, Y, Z, O), while the main artery continues and divides lower down to supply the lower extremities, and is picked up by the veins and returned to the heart through the inferior vena cava (7), while smaller veins return the blood from the stomach, spleen, intestines, etc., into and through the liver by way of the portal vein (3) before emptying through the inferior vena cava (7) into the heart. Thus there is a great amount of work thrown on the liver because during the digestive and assimilative processes a goodly proportion of the blood is drawn to these organs, and the liver must handle this extra quantity. A sluggish liver would necessarily impede the portal circulation and thus drive back the blood, which is supposed to be drained freely away from these organs during their activity. 1, Inferior vena cava; 2, aorta from heart; 3, 3, veins from liver (hepatic); 4, portal vein entering liver; 5, superior mesenteric vein; 6, right colic veins; 7, inferior vena cava; 8, left colic vein; 9, sigmoid vein; 10, abdominal aorta from heart; 11, splenic vein; X, hepatic artery; Y, inferior mesenteric; Z, superior mesenteric; O, splenic artery.



directly with the amount of material present. By this it is meant that the greater the amount of material in the rectum the greater the stimulation to the opening of the sphincter and discharge; second, the stimulation varies directly with the fluidity of the rectal contents; third, the act of defecation is controlled and regulated by the nervous mechanism and is both voluntary and reflex. The act is partly under control of the will, but not wholly so.

There is one other valve of the alimentary canal which should be considered and that is the ileo-cæcal valve, which lies between the ileum and the cæcum. Its function is to prevent the contents of the small gut from being passed into the cæcum too soon. "The lowest two centimeters of the ileum present a distinct thickening of the circular muscular coat, forming the ileocolic sphincter. This sphincter relaxes in front of a peristaltic wave and so allows the passage of food into the colon." (Starling.) This sphincter is not controlled by the vagus, but is regulated by the splanchnic fibers. This valve differs from other sphincter valves in that it has in addition to the sphincter two folds which form prominent projections into the cæcum.

### **THE ALIMENTARY CANAL FROM AN OSTEOPATHIC STANDPOINT.**

**The Stomach.**—The normal movements of the stomach we have given as due to normal stimulation by way of the vagus, causing peristalsis, also normal inhibition effected by nerve impulses by way of the spinal autonemics. Viscero-inhibition in this case means reduction of peristalsis. If for example in a normal animal the peripheral end of the vagus nerve be stimulated, there follows a peristaltic wave of the stomach, which goes through the latter and continues usually to the pyloric orifice and down through the gut. If, after this peristaltic wave is well started, the splanchnics leading to this segment of the alimentary canal are stimulated, inhibition of the wave results. The same thing may be caused if stimulation is applied to any sensory or mixed nerve leading into the cord. The stimulation of some efferent



or mixed nerve leading into the cord is equal in effect to the stimulation of the peripheral end of the spinal autonemics. It causes a condition of inhibition to the peristaltic movement in the alimentary canal. Stimulation of the vagus results in peristalsis, which is stopped by stimulation of the splanchnics. Now if a bony lesion is produced in the mid-dorsal or lower dorsal region and a peristalsis started by stimulation of the vagi, the stimulation of the central end of a sensory nerve does not inhibit peristalsis. Spinal lesions therefore interfere with normal functional activity of the nerves to the segment of the alimentary canal which they supply.

The question is sometimes asked, why do not animals suffer from disease conditions as a result of osteopathic lesions as human individuals do? The answer is that they do. No. 33 of Series 4, a large dog, about two years old, in a perfectly healthy condition, had a voracious appetite, eating about four times as much as a normal dog, but lost in weight all the time. On examination it was found to have a marked lesion of the fourth dorsal. This animal continued to decrease in weight. When it was found that it would not normalize, it was fed a full meal and killed about three hours afterward. The stomach contents were found to be almost entirely undigested, the secretions were decreased in amount, and there was evidence of fermentation.

The intestines are affected very much the same as the stomach by bony lesions of the spine. If the peripheral end of the vagus be stimulated a peristaltic wave is produced in the intestine which is inhibited by stimulation of the peripheral end of the splanchnics or the central end of some sensory or mixed nerve which leads into the cord; that is, the movement of the gut is either reduced or completely inhibited. If the animal is then lesioned in the mid-dorsal region and the experiment repeated the vagus causes peristalsis of the gut, but stimulation of the central end of a sensory or mixed nerve coming into the cord does not cause inhibition of the peristaltic wave. This means that in some way the lesion has prevented the normal function of the spinal autonemics from

inhibiting the peristaltic wave. The method by means of which it does this will be discussed later.

**Large Intestine.**—There probably is no one segment of the spinal region which is directly responsible for the cause of constipation or diarrhea, but the results are largely due to the fact that the lesion interferes with the normal movements and secretions of the large intestine, which, as already explained, might cause the contents of the gut to be retained in the colon, the result being bacterial fermentation and the formation of gas, causing excessive distension and irritation. This excessive irritation results in over-stimulation of the afferent nerves from the intestine and this causes excessive stimulation of efferent fibers, thereby causing a continued perversion of function.

**The Effects of Spinal Treatment.**—The correction of a lesion causative of such conditions normalizes the nerve supply. This in turn normalizes the blood supply and venous drainage and lymph supply and drainage to the structure involved, and normal function results. That is the mechanism by means of which osteopathic treatment is effective in these conditions. In case there is an osteopathic lesion interfering with the normal functions of the intestine, one might do almost anything else in the way of treatment without success.

**Experimental Evidence.**—Bony lesions when produced in the lower dorsal or lumbar spines of monkeys cause abnormal functions of the intestines, usually diarrhea, in from 24 to 48 hours. If after a few days the lesion be corrected the trouble ceases. This has been repeated several times on the same animal with similar results, but after several lesions have been produced at different times in the same animal treatment fails to relieve the symptoms. (Series No. 12.)

Dorsal and lumbar lesions in dogs have been shown to be causative factors of intestinal disturbances. (Series No. 4.) Sacral and innominate lesions also may cause intestinal troubles. (Series No. 13.)

**THE SPLEEN.**

There is little known about the functions of the spleen, regardless of the many theories that have been advanced. The spleen can be removed from an animal without causing serious injury. After extirpation certain changes have been observed such as an increased growth of the lymph glands, an increased growth of bone marrow, a diminution in the normal number of red cells, and a general decrease in the quantity of hemoglobin, but these results have not been confirmed by all workers on the subject.

The following theories of the function of the spleen have been advanced: 1. That it is in some way related to the function of red blood corpuscles; 2. that it is concerned with the regeneration of blood after hemorrhage. It is known that the spleen functions as an embryonic hematopoietic organ—that is it takes part as does the liver, in the formation of blood elements in the foetus before birth and probably for a short time after birth; 3. that it may be concerned with the formation of hemoglobin; 4. that it may be concerned with the destruction of red corpuscles; 5. that it may take part in the formation of uric acid by the action of certain enzymes on nucleins; 6. that the spleen produces a substance, probably an enzyme, which activates the trypsinogen of pancreatic juice.

Expansions and contractions of the spleen, the so-called splenic pulsations, have been noted during digestion, which are probably due to vaso-dilation and possibly to muscular contraction. The function of such movements is not known.

The spleen has no duct emptying into the alimentary canal like the pancreas and liver, but has a good blood supply and therefore its secretions, if any, are internal. The spleen receives a rich nerve supply of splanchnic fibers, probably vaso-dilators, vaso-constrictors, and trophic.

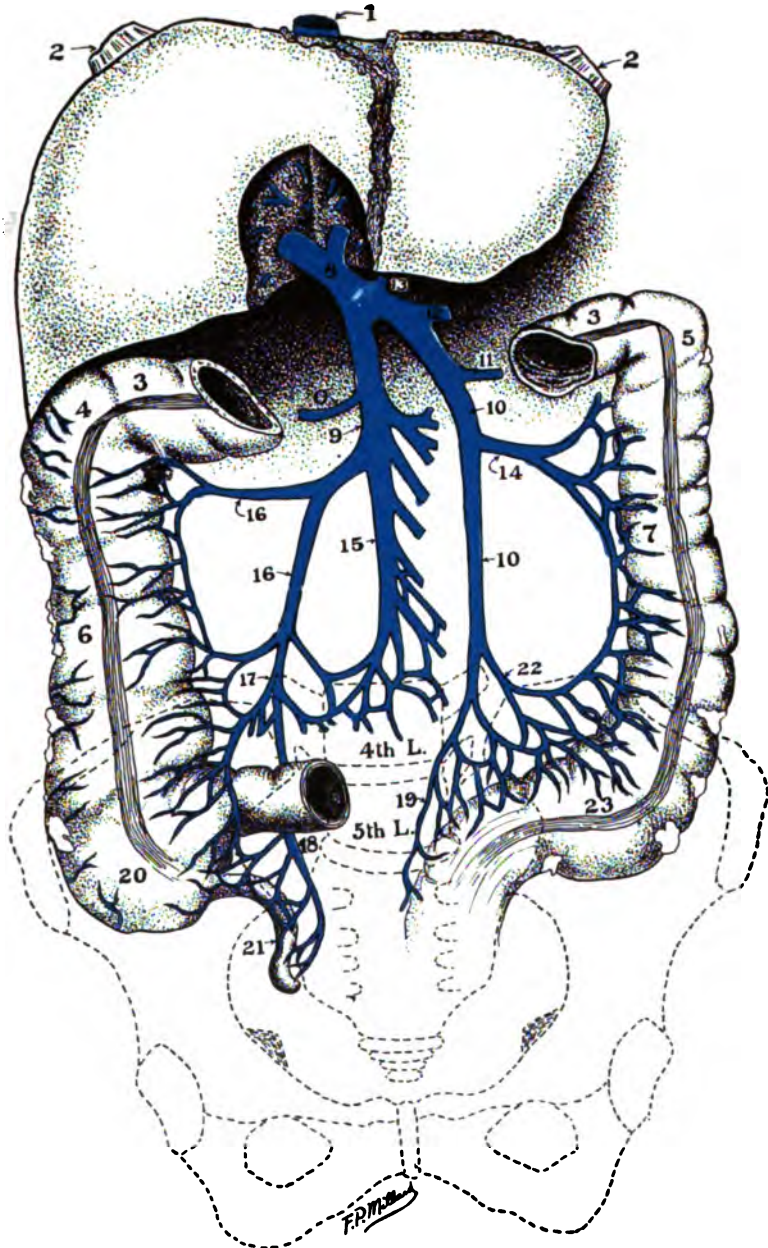

PLATE XXI.—Portal circulation to the liver, including blood from spleen, pancreas, stomach, and intestines: 1, Inferior vena cava; 2, 2, ligaments to support liver; 3, 3, transverse colon; 4, hepatic flexure; 5, splenic flexure; 6, ascending colon; 7, descending colon; 8, portal vein entering liver; 9, superior mesenteric vein; O, gastro ep. dextra vein (from stomach); 10, inferior mesenteric vein; 11, gastro ep. sinistra (from stomach); 12, splenic vein; 13, coronary (from stomach); 14, left colic vein; 15, 16, right colic branches; 17, ileo-colic; 18, appendiceal vein; 19, superior hemorrhoidal; 20, caecum; 21, appendix; 22, sigmoid vein; 23, sigmoid flexure; 4 L., fourth lumbar; 5 L., fifth lumbar.



## CHAPTER XVIII.

### EXCRETORY ORGANS.

**The Kidneys.**—It is expected that students who use this book will review the histology and anatomy of the structure studied from their texts on these subjects, therefore no lengthy discussion will be given. From a study of the histology of the kidney it will be seen that there are structures which are seemingly adapted to filtration (the glomeruli) and other structures adapted for secretion (uriniferous tubules).

**Nerve Supply.**—It has been shown that the kidneys receive a rich nerve supply from the splanchnics which probably originate from the lower dorsal and upper lumbar segments of the cord. It is stated that stimulation of these nerves results in vasoconstriction of the small arteries of the kidney, a reduction in the size of the organ, and a diminished secretion of urine, while cutting these fibers seems to result in vaso dilation due to loss of tone to the vessel walls, which is followed by an increase in the flow of urine. (See osteopathic experiments).

It is generally supposed that these fibers regulate the flow of urine by reflex; that is, by the regulation of the blood supply of the kidney. Bradford has shown that vaso-dilator fibers from the lower thoracic segments of the cord supply the kidney, which when stimulated increase the flow of urine reflexly. Afferent fibers are probably present in these nerves which enter into the reflex mechanism. Secretory nerves have not been demonstrated.

**Formation of Urine in the Kidneys.**—Since secretory nerves to the kidney have not been demonstrated it is generally conceded that the formation of urine is effected by changes in the blood supply; that is, that the secretion of urine, like the secretion

of bile, varies directly with the blood supply. (See osteopathic considerations.)

Two general theories have been advanced relative to the formation of urine, viz., secretion, and secretion and diffusion. Evidence in favor of the latter theory is as follows:

1. The structure of the glomeruli is such that filtration would seem probable and according to Ludwig such substances as inorganic salts, urea, water, etc., were so produced from the blood. According to this theory it was supposed that other substances of the urine came from the tubules by a process of diffusion. The theory of Bowman and Heidenhain was similar to that of Ludwig except that they held that the glomeruli produced water and inorganic salts and the urea and other substances were produced by the epithelial cells of the convoluted tubules by a method of selective absorption. The work of the epithelial cells is explained by attributing to them the function of selective absorption, which was supposed to be due to some special function of these cells. Whether this is the true explanation has never been demonstrated, but most authorities now consider the functions of the tubules as secretory rather than as stated above.

2. Since secretory nerves have not been demonstrated and since there is good evidence to show that the formation of urine is increased by an increased blood supply to the kidney, this is further reason for believing in the filtration theory. The increased pressure caused in the kidney by blocking the venous drainage is not followed by increased secretion, but this is insufficient argument against the theory of filtration. The theory of Heidenhain as given above seems to be more in harmony with the experimental evidence.

3. The capillary pressure in the kidney is from 50 to 75 m. m. of Hg, which fact would seem to favor the filtration theory.

4. It has been shown in the extirpated kidney that if water pressure be connected to the renal artery it will flow through the kidney and into the ureters (Soleman), but this is not of great significance.

5. It has been shown that either the tubules or glomeruli can secrete normal urine. (Meisbaum's experiment.)

**Secretion Theory.**—The evidence adduced in favor of the secretion theory is as follows:

1. The rate of urine formation is increased as the rate of blood-flow through the kidney is increased. The rate of flow would not necessarily influence filtration. It is supposed that the arterial blood may stimulate the secretory cells and thus increase the formation of urine.

2. After injection of certain substances into the blood stream (indigo carmine) granules of these substances may be found in the epithelial cells of the convoluted tubules, showing that these cells seem to have the power of separating these substances from the blood.

3. It has been shown that iron, uric acid, and some other substances are separated from the blood by the epithelium of the tubules.

4. The fact that sugar is normally present in the blood and is normally absent in the urine has been used as argument against the filtration theory.

5. It would seem that the histological structure of the tubules is best adapted for secretion.

6. There is some reason to believe that diuretics cause the increase in urine formation by stimulating the secretory cells directly. There is no doubt that certain diuretics such as digitalis, caffeine, etc., will produce an increased flow of urine, but there are many other substances, such as dextrose, urea, and certain organic salts which will do this, and as yet no satisfactory explanation of their action has been given. Water is probably the best of all diuretics.

To summarize, it may be said that no conclusion can be reached from the experimental evidence at hand, but that both factors, secretion and filtration, probably play important parts in the formation of urine. It has been shown by Schafer that a substance (internal secretion) produced by the nerve portion of the pituitary body acts as an active diuretic.



PROPERTIES AND CONSTITUENTS OF URINE AS COMPARED WITH BLOOD.

	Urine	Blood
Color	Yellowish (variable)	Scarlet or purple (variable)
Specific gravity	1.020 (average)	1.055 (average)
Reaction	Normally acid, due to acid phosphates	Neutral or slightly alkaline
Urea	2% (variable)	.02— .04%
Inorganic salts	1.5 % (variable)	.85%
Proteins	A trace only	Variable amounts
Sugar	Normally absent	.09— .2% (almost constant)

**Kidney Excretions.**—The following is a list taken from Starling showing the average elimination in 24 hours of an adult man on ordinary mixed diet. Total amount of urine, 1,500 c.c. This contains about 60 gm. of salts, of which 25 gm. are inorganic and 35 gm. organic. These are distributed as follows (Starling, p. 1242):

Inorganic Constituents.	Organic Constituents.
Sodium chlorids.....15.0 grm.	Urea.....30.0 grm.
Sulphuric acid..... 2.5 "	Uric acid..... 0.7 "
Phosphoric acid..... 2.5 "	Creatinine..... 1.0 "
Potassium..... 3.3 "	Hippuric acid..... 0.7 "
Ammonia..... 0.7 "	Other substances..... 2.6 "
Magnesia..... 0.5 "	
Lime..... 0.3 "	
Other substances..... 0.2 "	

The kidneys are the chief excretory organs for nitrogen, which is eliminated chiefly in the form of urea. The chemistry of the process, as well as other products given above, is to be found in texts on physiological chemistry.

**Water Elimination.**—There are three main channels, viz., the kidneys, the skin, and the lungs, a small portion being eliminated by way of the rectum. The greatest amount of water is eliminated through the kidneys (average, 1,500 to 1,700 c. c. daily for an adult man). This quantity varies inversely with the amount eliminated by the other channels, especially the skin. If there is much sweat (under certain conditions it may be as great as or even exceed the kidney elimination) the urine is decreased in amount and increased in its solid content.

**Micturition.**—The formation of urine in the kidney is a constant process (from one to five drops per minute for each kidney)

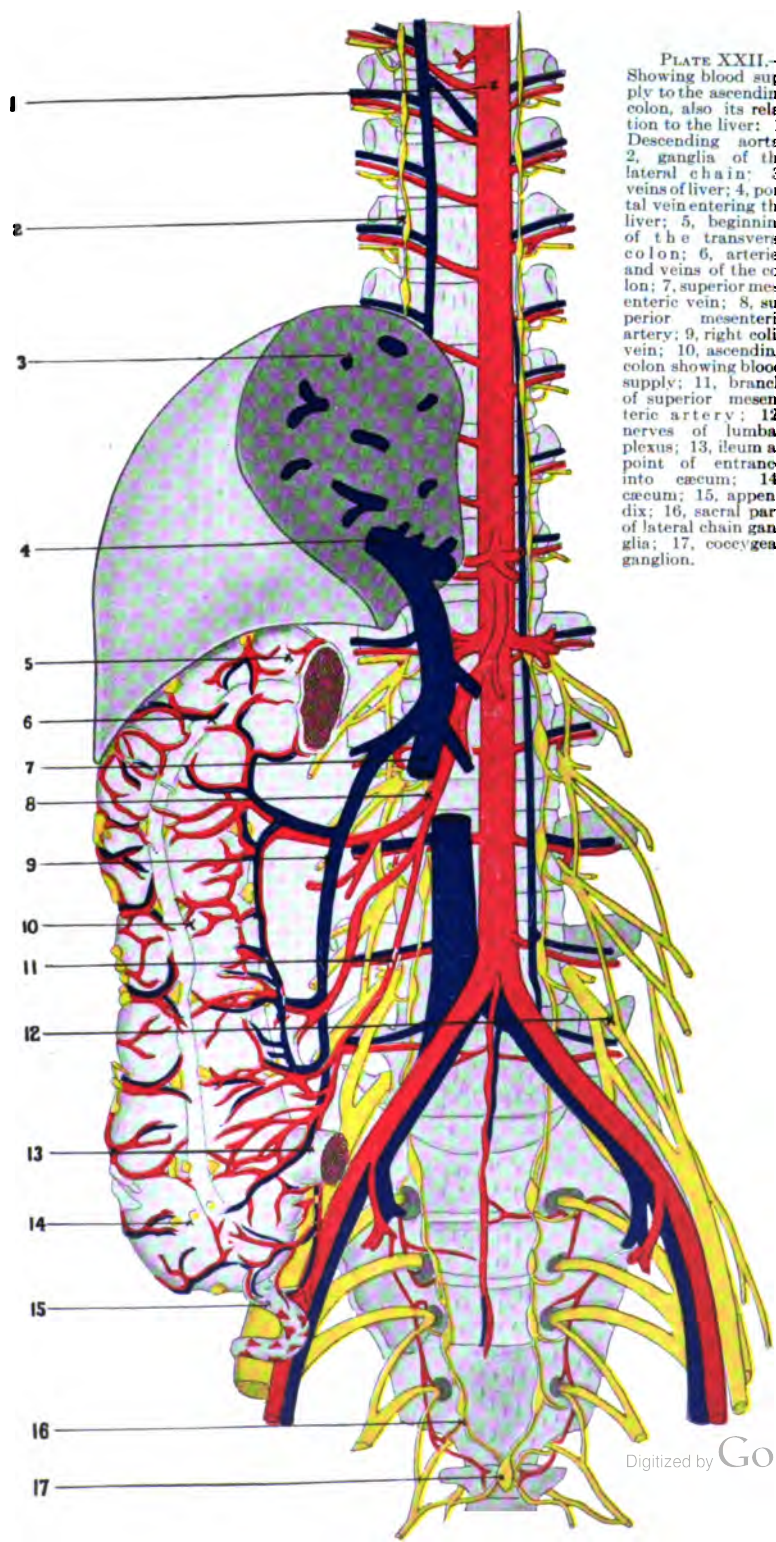

PLATE XXII.—  
 Showing blood supply to the ascending colon, also its relation to the liver: 1, Descending aorta; 2, ganglia of the lateral chain; 3, veins of liver; 4, portal vein entering the liver; 5, beginning of the transverse colon; 6, arteries and veins of the colon; 7, superior mesenteric vein; 8, superior mesenteric artery; 9, right colic vein; 10, ascending colon showing blood supply; 11, branch of superior mesenteric artery; 12, nerves of lumbar plexus; 13, ileum at point of entrance into caecum; 14, caecum; 15, appendix; 16, sacral part of lateral chain ganglia; 17, coccygeal ganglion.

s  
i  
t  
t  
n  
h  
t  
q  
t  
o  
s  
h  
t  
o  
o  
d  
p  
a  
o  
i  
r  
f  
t

and it is carried to the bladder by the ureters, which perform this function by peristalsis of its smooth-muscle walls. Whether this peristalsis which moves at rather regular intervals from the kidney to the bladder is regulated by extrinsic or intrinsic nerve mechanism, or whether it is due to automaticity of its muculature, has not been determined. Gravity plays no essential part in the process. The bladder dilates to accommodate the increasing quantity of urine, which is finally discharged from the bladder through the urethra.

**The Bladder.**—The bladder wall consists of three muscular coats—middle, circular, and inner and outer longitudinal. Two sphincters of the urethra, an internal and an external, which consist of augmentations of the circular fibers at these points, regulate the discharge of urine from the bladder. The tonic contractions of the internal sphincter, aided by the elasticity, are the causes of retention of urine until proper time for its discharge. The discharge of urine is normally under voluntary control, but is probably regulated by reflex in children and to some extent in adults. There is experimental evidence to show that the discharge of urine in dogs is regulated almost wholly by reflex.

**Nerve Supply of the Bladder.**—Viscero-motor fibers causing constriction of the bladder are supplied by the hypogastric nerves and plexuses from the inferior mesenteric ganglion. These fibers come from the second, third, and fourth lumbar segments of the cord. The chief viscero-motor fibers of the bladder walls are supplied from the sacral segments, third, fourth, and fifth. Sensory fibers to the walls of the bladder are supplied by the hypogastric nerves and the sacral nerves. (Landois.) The vesico-spinal center for reflex stimulation of the bladder is located about the fourth lumbar segment of the spine. Evacuation of urine may also be caused by stimulation of other sensory nerves. The urethro-spinal center is located about the fifth lumbar segment of the spine. (Landois.) The reflex mechanism of this center probably plays some important part in the act of micturition. The same author states that "From the cerebral cortex the voluntary motor paths course downward through the spinal cord to

the sphincter muscle of the urethra, within the pyramidal tracts." Similar cortical paths are claimed to exist for other visceral functions, but this is not generally confirmed by other physiologists. There is, however, much evidence to show that there is some connecting nerve mechanism between the centers regulating these functions and the cortex, but the connecting pathways are not known.

**Osteopathic Considerations.**—It has been shown, Series 4 and 12, that bony lesions of the lower thoracic and upper lumbar regions produced artificially in normal animals affect the normal functions of the kidneys. Clinically many cases of kidney trouble have been demonstrated to be due to similar lesions.

In Series No. 16, Pengra and Alexander have conclusively shown that the secretions of the kidneys can be increased from 25 to 100% by stimulatory treatment applied to the eleventh and twelfth thoracic segments of the spine. The secretion thus produced often remains increased for two or three hours or longer, during which time the water content of the body is greatly reduced. This same experiment has been tried with equal success on the human, and by this means in cases of febrile conditions the toxins of the body fluids and the temperature have been much reduced in a number of cases in which the test has been applied.

The practical significance of such treatment is therefore apparent. If the toxin content of the blood can be materially reduced, as this experimental evidence shows it can be, this is a very efficient method of treatment in infectious fevers. Spinal manipulation which produces free movement between the vertebræ named should be continued for ten or fifteen minutes at each treatment and several such treatments given daily during the febrile state. Dr. McConnell has shown that bony lesions of the mid and lower dorsal regions are followed by pathological lesions of the kidney.

## THE SKIN.

The functions of the skin are many and varied.

1. It forms a sensory receptor surface for the adjustment of internal functional activities to external environment by means of nerve-reflex mechanism. There are a great many specifically receptive surfaces supplied by specific afferent nerve fibers, such as pressure, temperature, pain, and many others, the specific afferent associations of which assist in the regulation of body adjustment to the demands of function.

2. The regulation of body temperature which is affected by the production of sweat and the cooling of the blood by peripheral vaso-dilation.

3. The formation of certain essential secretions such as sweat, sebum and milk, the mammary glands being modified glands of the skin.

4. Another function, that of protection to the underlying structures, is ascribed to the skin.

5. It is an established fact that watery solutions are not absorbed by normal skin, therefore the fallacy of the so-called medicinal baths. Mud is surely no more soluble than water. There are certain substances which may be absorbed to some extent in the form of fatty inunctions, but cod-liver oil, for example, is not absorbed in sufficient quantities to be highly nutritious.

6. As an organ of excretion two sets of glands are to be studied, viz., sweat glands and sebaceous glands.

**Sweat Glands.**—Sweat may properly be termed a secretion and an excretion. As an excretion it reduces the body water content and throws off some other substances. (See contents below.) Secretory glands for the production of the perspiration may be found in all skin surfaces except the glans penis, the prepuce and the external auditory meatus. These glands are found in greatest numbers on the soles of the feet and the palms of the hands. The secretion produced by these glands varies from 500 c. c. to 1,000 c. c. daily, the amount being influenced by many conditions, e. g., temperature of the body, temperature of the

environment, muscular exercise, and psychic conditions. There are certain infectious fevers, the toxins of which by their effect on the thermogenic and vasomotor centers influence sweating. In general it may be said that the activities of the kidneys and skin vary in an inverse ratio; that is, if the kidneys are highly functional the secretion of sweat by means of the skin is decreased, and the converse is also true. In summer there is a greater amount of sweat produced and a comparatively smaller amount of secretion from the kidneys, if the water intake is constant.

**General Properties and Constituents of Sweat.**—Sweat is a clear, colorless fluid. When first secreted it is alkaline, later becoming acid in reaction, has a specific gravity of 1.003, and contains the following substances: water, 99%; sodium chloride and other inorganic salts, 0.3 to 0.6%; proteins, a trace; urea, a trace.

**Secretory Nerves.**—That the secretion of sweat is regulated by the central nervous system, both directly and reflexly, has been conclusively shown experimentally. If the sciatic nerve be cut in one leg of a cat and the animal be placed in an incubator, the temperature of which is kept slightly above normal, sweat will appear on the pads of the feet, but not on the one the nerve of which has been sectioned. The most probable explanation is that the increased temperature of the blood (from .5° C. to 1° C. above normal is sufficient) stimulates the nerve centers controlling this function to increased activity. The same explanation holds for increased sweating caused by the Turkish bath. It has been shown that warming of the blood of the carotid arteries and asphyxia may increase the secretion of sweat, which would seem to be evidence of a sweat center in the medulla, but no positive proof of such center exists.

Stimulation of the peripheral end of the sciatic nerve in a freshly amputated limb of a cat causes the formation of sweat droplets on the pads of the foot, which shows that the secretion may be affected by direct stimulation. The sweating which results from stimulation of the central ends of afferent or mixed

nerves may be attributed to reflex effects, probably due to vaso-motor changes, in the structures supplied. The sweat-nerves pass to the structures via the spinal autonemics originating from the second thoracic to the fourth lumbar. (Langley.)

**Cutaneous Respiration.**—CO<sub>2</sub> is given off from the skin in variable quantities, varying from 6 gms. to 10 gms. in 24 hours. If there is much sweating the amount is much increased. There is probably a very small amount of oxygen taken in through the skin in the human, but in some animals (the frog) the skin may function as an essential respiratory organ.

**Secretion of Sebum.**—The ducts of the sebaceous glands for the most part empty in common with the hair follicles. The secretions of these glands consist of cell detritus, formed from the degenerated cells of the sebaceous glands. Sebum consists of fats, soaps, albuminous material, etc., and is collected from some animals (sheep) and made into a commercial preparation, lanolin, which, because of the fact that it does not melt readily at body temperature, makes an excellent application for erythematous eruptions. Other forms of sebum are smegma, formed by the prepuce, cerumen (ear wax) of the external auditory meatus, and vernix caseosa, the cheese-like covering of the foetus. The function of sebum is protection of skin and hair, and as an excretion it rids the skin of cell detritus.

**Osteopathic Considerations.**—Bony or muscular lesions, particularly of the upper thoracic region, have been shown clinically to affect sweat secretion; and that spinal treatment will increase the flow of sweat has been demonstrated. The reduction of fever temperature by osteopathic treatment may properly be ascribed to the increased elimination by means of sweat secretion.





# SECTION IV

---

## METABOLISM AND BODY ENERGY



## CHAPTER XIX.

# PROTEIN AND CARBOHYDRATE METABOLISM.

Quantitative analysis of the protein molecule shows it to contain about sixteen per cent of nitrogen. The study of protein metabolism therefore concerns chiefly the nitrogen changes, and to determine the protein metabolism in the body, an estimation of the nitrogen content of the food ingested during a certain period and an estimation of the nitrogen content of the excreta—urine, sweat and feces—will show whether the animal is losing, gaining, or remaining constant. If the nitrogen content of the excreta is the same as that of the food ingested, the animal is said to be in a state of nitrogen equilibrium. If the nitrogen excreted is greater than that ingested, the individual is in a state of nitrogen minus, and if the nitrogen intake is greater than the amount excreted, the individual is in a state of nitrogen plus, which means that the individual is storing proteins.

In the growing individual and during convalescence from infectious diseases, etc., the body is in a condition of nitrogen plus. In starvation, old age, and during the active stages of certain diseases the body is in a state of nitrogen minus, while during the period of adult life on normal diet the protein metabolism is in balance or nitrogen equilibrium.

The same comparisons may be made for the carbohydrates, by determining the carbon content in the  $\text{CO}_2$ , urine, etc. excreted in proportion to the carbon intake. Under normal conditions in adult life, the carbon is also in equilibrium.

By reference to the chapter on foods it will be seen that the various food stuffs have more or less specific functions, viz.: The proteins build tissue and the carbohydrates and fats furnish energy

for heat, work, etc. It may be seen that the body may vary in these respects according to the metabolism of the various foods; that is, one kind of food might be in equilibrium while another could be either minus or plus, or they may all be in equilibrium, in which condition the body is said to be in complete balance. This condition may also be determined by a complete analysis of the food and air taken in, and the excreta, including the expired air, given off. The respiration chamber, to be described later, is used for this purpose.

**Amount of Protein Necessary.**—The average individual, according to Howell, uses from 100 to 120 grams of protein daily. About 100 grams are used and the rest thrown off in the excreta. Various workers in physiological research have endeavored to determine the amount actually needed, and the noteworthy researches of Chittenden (his results may be found in his book, "Nutrition of Man") have shown that the protein food may be much reduced without reducing the individual's physical or mental powers. His results show that complete efficiency can be maintained on from 30 to 50 grams of protein daily. Chittenden himself and many of his Yale students experimented upon and did well on a much less amount than this. Some college athletes seemed to have an actual increase in energy on 50 grams or less daily. He claims that an excess of proteins taken in diet means only useless work in digestion, and therefore a decreased resistance and efficiency. The question here arises relative to the long continued use of such a diet. It is known that men engaged in hard work take more protein and seem to do well on such a diet, and while the results given by Chittenden are quite conclusive, we are inclined to question whether they would stand a practical, long continued test.

**Protein Sparers.**—It is known that a state of nitrogen equilibrium may be maintained on a comparatively small amount of protein foods if other foods—carbohydrates and fats—in plentiful amounts be given in the diet. These foods are therefore known as protein spacers, as they seem to lessen the demand for proteins. The explanation is that the protein foods must have two functions:

First, tissue builders; second, supply of energy to living tissues. If then, this second function can be replaced by the carbohydrates and fats which are known to have the power of yielding energy the proteins would be left to perform the one and their chief function, that of tissue building, and therefore a much less amount would be needed.

### **CARBOHYDRATE METABOLISM.**

As has been stated in the chapters on digestion and absorption, the starchy foods are reduced to soluble sugars, in which form they are carried to the liver by the portal vein and stored in the liver in the form of glycogen. The liver glycogen, then, furnishes the chief source of carbohydrates for the use of the body as it is needed. The liver may vary greatly in its glycogen content from possibly 4% or 5% to 15% or even more, while the other organs concerned in carbohydrate metabolism remain rather constant in their sugar content. The sugar of the blood is always normally from .1% to .2%. The glycogen content of muscle is variable, but much more constant than in the liver. In the foetus and young child the muscle may serve as a glycogen storer, but in the adult, muscle contains from .4% to 1% of glycogen.

Carbohydrates are carried in the blood in the form of soluble sugar (dextrose) and are re-stored in the muscles as glycogen. This change in the carbohydrates is necessary, and is probably effected by some enzyme action in the liver and muscle. By this method the liver is constantly furnishing the supply of carbohydrate material for the various structures of the body when needed. Other structures such as the pancreas, as has been stated, are concerned in the metabolism of the carbohydrates. The function of these regulators of carbohydrate metabolism are to some extent under the control of the nervous system, and therefore any inefficiency of this system may materially affect these functions. It has been shown that puncture of the medulla affects carbohydrate metabolism, and there is supposed to be a center for the regulation of such functions located there. If the splanch-

nic nerves be sectioned, or if the cord be cut above the fourth dorsal segment no glycosuria results from puncture of the medulla, which would seem to show that some spinal-cord mechanism is involved in the function of those structures which regulate carbohydrate metabolism. Attention has also been called to the unity of functional activity of the "splanchnic triad"—the liver, duodenum and pancreas and how the normal functions of one depend upon the others. Any of these structures, then, may be concerned with this storing and regulating of the carbohydrates. If for any reason the sugars of the blood are not reduced to glycogen and properly stored by the liver or muscles, a condition of hyperglycemia (excess of sugar in the blood) follows and as this must be excreted by the kidneys, glycosuria or sugar in the urine results, and because of this the body suffers from lack of this foodstuff as a heat and energy producer, and therefore body energy and resistance are both reduced. The disease diabetes mellitus is characterized by glycosuria, polyuria, loss of weight and energy, and reduced resistance to other diseases. It may therefore be seen that the normal function of all structures concerned in carbohydrate metabolism is very essential to health.

Normal carbohydrate metabolism may be affected, causing glycosuria, in the following ways: 1. Puncture or other lesion of the medulla; 2. Stimulation of the vagus or, indeed, any lesion affecting any sensory nerve; 3. Pathological lesions of the spinal cord; 4. Any deficiency of the functions of the pancreas, whether by degeneration or other pathological lesion or by an interference with its nerve supply; 5. Any deficiency in the normal functions of the liver or muscles which renders them unable to change the sugars and store the glycogen. To this list of causes given in general physiology may be added the osteopathic lesions, viz.: 6. Any visceral lesion interfering with the functions of the pancreas, liver, duodenum, kidney, etc., or the nerve supply to these organs, and 7. Bony lesions of the mid and lower dorsal regions. (See series 4, and series 12.)

In diabetes mellitus not only are the carbohydrate foods not utilized, but even the proteins are reduced to sugar and eliminated; thus the loss of tissue building function and the emaciation.

**Functions of the Carbohydrates.**—These foods have several important functions, as follows: 1. They may act as protein spacers, as described above; 2. They furnish energy for muscle activity, etc.; 3. They provide heat by oxidation, and 4. An excess of carbohydrate material may be reduced to fat and stored in the body as such. The changes by which this is effected are not known, but there is ample evidence that it does occur.



## CHAPTER XX.

### METABOLISM OF FATS AND ACCESSORY FOODS.

To understand the history of the metabolism of fats it is necessary to review the changes in digestion and absorption. Fats are taken from the blood and lymph into the tissue by some process of selective absorption peculiar to the tissue cells. Oxidation of these fats results in the production of  $\text{CO}_2$ , water, energy, and heat.

**Functions of Fat in the Body.**—1. As given, oxidation results in heat and energy; 2. Fats may be stored as a reserve supply and for protection, etc; 3. Fat products may be changed to other substances, such as lecithin; 4. It may function as a protein sparer, and 5. There is evidence to show that it may under some conditions be changed to sugar.

**Source of Fats in the Body.**—It is probable that the carbohydrates furnish the chief source of fats. Some fats come from the animal and vegetable fats taken in the diet, and some from the proteins. In the case of animal fats they may be stored in the same form as eaten.

**Individual Variation.**—There is little known about the causes which underlie fat deposition in the body, and only general reasons can be given. The chief cause of fat deposit in those individuals who live a normal life with sufficient exercise is the inability of the system to destroy the food material taken. Fats are destroyed chiefly by oxidation, and it is probable that there is a lack of certain internal secretions which effect fat oxidation. It is known that the ovaries and testes play an important role in this function, and that after extirpation of the ovaries in animals and after the menopause in women there is a tendency to lay on fat.

Various theories have been given, e. g., hereditary tendencies, individual variations, etc., none of which have any particular significance, but for the average individual the following factors play important parts in his fat metabolism: Rest is always essential to fat deposition, and the sedentary lives of many is perhaps responsible for their excessive weight; activity and fat formation vary inversely, but this is limited; alcoholism often results in fat deposition, the oxidation of the alcohol protecting the fats. In that way it acts as a fat sparer.

**Inorganic Salts.**—Body ash consists essentially of the chlorides, phosphates, carbonates, fluorides, salicylates, sulphates, etc., of calcium, magnesium, potassium and a few other metals in traces.

The functions of the inorganic salts are as follows:

1. Maintenance of constant density of body fluids; 2. some have specific functions, such as calcium salts in blood clotting and milk curdling, iron in assisting hemoglobin in its oxygen carrying power, iodine, calcium, and possibly others in certain internal secretions, and again it seems that certain salts are necessary to the vital functions of certain cells. The irritability of muscle and nerve cells, for example, seem to be increased by the action of calcium salts.

### ACCESSORY FOODS.

**Stimulants.**—The effects of secretagogues from the meat extracts, soups, etc., have been discussed elsewhere. They constitute normal stimulants to gastric secretion.

**Coffee and Tea** effect stimulation by their proximate principle, caffeine. It is considered as a nerve stimulant, increasing blood pressure; a stomachic tonic, slightly laxative and diuretic, and is injurious only in excessive quantities, the dose of the drug being from one to three grains. Large amounts of coffee diminish fatigue and prevent sleep.

**Cocoa and Chocolate** contain much nourishment. The alkaloid theo-bromin is a stimulant, but not in any way detrimental in ordinary quantities. Twenty to thirty grams may be used daily.

**Alcohol** in small amounts stimulates secretion and absorption, and may be of some benefit in the aged. It is also a protein, carbohydrate and fat sparer, and may properly be considered a food in these respects. The evil effects of alcohol come only from the excessive use or the cultivation of the habit. It has been demonstrated that the use of alcohol in excess for long periods results in pathological changes in the stomach, heart, liver, nervous system, etc. Conditions of acute troubles may also result from single overdoses of alcohol. For these reasons alcohol cannot be considered a practical food. Alcohol acts as a paralyzant on the inhibitory motor centers, and in this way causes the apparent increase in muscular efficiency. In small quantities it is not a heart stimulant, but causes peripheral vaso-dilation in any quantity and in this way causes loss of energy and body cooling, but these effects are not lasting.

**Condiments, Flavors, etc.**—Nothing can be said against the moderate use of these substances. They often hasten digestion and secretion, and enable the individual to eat well. By the stimulation of the “appetite juice”—the so-called psychic secretion—and by increasing the appetite, these substances often do much good.

## CHAPTER XXI.

### BODY ENERGY.

In previous chapters in the discussion of the various functions of foods it has been stated that the carbohydrates and fats furnish the chief source of body energy. The energy yielded to the body by these foods comes from a breaking down of the complex chemical compounds, chiefly by a process of oxidation. Such reactions result in the formation of simpler compounds and energy. The energy may be in one or more of several forms. The result of such an action may be compared to the discharge of powder in a gun. For example, the stimulus by way of a nerve may be compared to the primer which ignites the powder. The reduction of the complex organic compounds to the simpler products may be compared to the quick combustion of the nitrates and sulphates of the powder to their simpler forms. The energy yielded which does work in moving muscle, producing nerve force, etc., may likewise be compared to the energy yielded which drives the shot, and the heat energy which results, causing an increase in the body temperature, etc., with the heat energy which accompanies the powder explosion. It is in each case a result of an exothermic chemical change produced by the chemical reaction.

Man is a machine in the strictest sense, and in no phase of mechanics do the laws of the conservation and transformation of energy hold more true. The source of energy in the animal is the complex chemical compounds of plants and other animals which it takes in the form of food. The animal has no power to generate energy within its own body. The only thing it can do is to transform this potential energy of the complex compounds into other forms useful to itself. These compounds when properly transformed are again like the powder charge in the gun; they

constitute the potential energy which may at will, as in case of the carbohydrate supply of voluntary muscle, be converted into kinetic or active energy by the function of the nerve impulse supplying the structure. The study of digestion and metabolism, then, becomes a study of the transformation of energy.

The forms of energy resulting may be many and varied. For example, the energy to move muscle, the energy causing secretion, the energy which furnishes the cell with its power of specific function, the energy giving origin to nerve force, electrical energy which probably influences chemical changes, the heat energy which results from exothermic chemical changes and to some extent from friction, all have their various functions. In the law of conservation of energy we also have an important lesson for physiological study: Energy can be transformed but not generated. The animal must get his supply of energy from his foods.

During the many years of structural adaptation the animal has developed its machinery to the highest degree of efficiency.

In mechanics' efficiency =  $\frac{\text{work done (ergs)}}{\text{force applied (dynes)}}$ . It has been

found that in the case of men doing work such as mountain climbing, from 35% to 40% of the energy yielded from oxidation of foods is utilized in work done. (Work = force applied through a distance.) By comparing this efficiency with that of machines (engines utilize from 15% to 25%) it will be seen that the human machine is most excellently adapted for the work which it has to do.

**Measurement of the Body Energies.**—The Atwater respiration calorimeter chamber is a device used for the study of the energy of man. It consists of an air-tight, heat-tight chamber sufficiently large for the individual to live in for a length of time. It is so arranged that the oxygen and CO<sub>2</sub> content of air breathed and the oxygen and CO<sub>2</sub> content of the expired air may be determined. The heat equivalent of the food eaten may be determined by oxidizing, and the heat equivalent of the excreta may be determined in the same way. By placing a machine in

the chamber upon which the man may do work and have this work recorded, for which purpose a bicycle ergometer is used and the estimations made as follows, accurate results may be obtained:

1. Heat equivalent of total amount of food taken determined.
2. Excreta collected and completely oxidized and this deducted from (1).
3. CO<sub>2</sub> collected and calculated.
4. Work recorded on bicycle ergometer measured.

Calculation:

1 — 2 = amount of heat from food by body;

3 + 4 = total amount of oxidation and work done;

Therefore 1 — 2 = 3 + 4.

## CHAPTER XXII.

### BODY ENERGY AND BODY TEMPERATURE.

**Source of Body Heat.**—The chief source of heat energy in the body is the oxidation changes. These changes for the most part occur within the living cells, giving functional energy to the cells and increasing the chemical changes in and about the cell. It is known that chemical changes, metabolic in nature, are increased by an increase in temperature in the body just as they are “in vitro.” Friction of the blood as it moves in the vessels is responsible for only a very small part of the body-heat production, and friction of the muscles results in the production of a much less amount of heat energy. The temperature of the food ingested, as in case of hot drinks, etc., may in some instances increase the total body temperature.

**Heat Production, How Regulated.**—It may readily be seen that this is an important factor in body metabolism, as so much depends upon the influence of heat production. Several factors are concerned, such as

1. The quantity of food.
2. The kind of food taken, some yielding more heat energy than others.
3. The activity of skeletal muscle.
4. Influence of nerve-regulating mechanism, such as the vasomotors which regulate the blood supply, and by their trophic effects regulate cellular metabolism.

**Muscular Exercise.**—That muscular exercise increases the demand for food and the amount used in metabolism has been demonstrated scientifically. Several theories have been advanced to explain this, some of which will be briefly given: Liebig has advanced the theory of two general functions of food, viz., oxida-

tion for the supply of heat, which function is fulfilled by the carbohydrates and fats, and the other main function, that of tissue building, which is effected by the proteins. Since muscle tissue, according to this theory, needs protein for tissue building, it was assumed that protein foods furnished the chief source of energy for muscular work. It was conclusively proven by Fick and Wislicenus in tests made on themselves while mountain climbing, during which time they used a non-protein diet, that certainly not all the energy for muscular work came from protein oxidation. Voit has further shown by experiments on man, using the respiration chamber, that moderate muscular exercise does not affect the protein oxidation. It has now been conclusively shown that the non-protein foods are responsible for the source of energy for muscular work, but if the muscular work be excessive there is some wear of the muscle tissue which can only be repaired by protein food.

**Regulation of Loss of Body Heat.**—About 73% of the total loss of heat is by radiation, which is regulated by clothing and the temperature of the surrounding air.

Evaporation of moisture from the skin, which is determined to some extent by clothing but principally by the vasomotor mechanism, is also responsible for a large amount of loss of body heat. This excessive secretion of sweat is effected in one or more of several ways:

1. By vaso-dilation, caused possibly by direct or reflex stimulation of vaso-dilator centers, and
2. Vaso-dilation caused by direct or reflex inhibition of the vaso-constrictor centers.
3. Direct or reflex stimulation of some specific nerves regulating sweat secretion, as described under the secretion of sweat.

The temperature-regulating mechanism is involuntary, and is effected almost wholly by reflex.

The mechanism by means of which vasomotor and secretory functions are regulated by specific afferent nerves from skin surfaces will be discussed elsewhere.



By covering the body with vaseline one may swim in water at 45° F. without experiencing discomfort from cold. (Carlson.)

There is also some evaporation of moisture from the lungs, and this reduces body temperature. In some animals, the dog for example, the chief mechanism for the reduction of temperature is evaporation from the lungs and the cooling of the lungs by breathing; therefore the rapid panting of such animals when hot.

A third way in which body heat is reduced is by the warming of inspired air by the lungs. All air when expired is warmed to, or nearly to, body temperature. If the temperature of inspired air is below that of body temperature, which is nearly always the case, there is some cooling of the lungs during each inspiration.

There is also some loss of heat by means of the excreta, but the heat lost in this way is not great.

**Nerve Mechanism for Heat Regulation.**—Much experimentation has been done, but as yet little is known regarding the mechanism by means of which the nervous system regulates body temperature. It may be that specific calorific nerves supply the visceral structures which regulate the oxidation processes in such a way as to effect thermogenesis; but while there is much physiological evidence in favor of this view, such specific nerves have never been demonstrated.

That thermogenic or heat-regulating centers exist has been shown by operations on the brain and cord. The following facts have been demonstrated: Puncture or section of the medulla just behind the pons is followed by an increase in body temperature and an actual increase of body heat production, and cutting the cord in the lower cervical is followed by opposite results. There is also evidence to show that section of or injury to the cord in the upper dorsal region interferes with temperature regulation. Ott seems to have demonstrated a "heat center" in the corpus striatum, and other supposed centers which have something to do with heat production or body-temperature regulation have been located in the optic thalamus, in the septum lucidum, the cortex, mid brain, medulla and pons, but little is known other than that they seem to cause some thermic disturbance.

From the evidence at hand we may conclude that there probably are centers in the brain and brain stem which inhibit the activity of centers lower in the cord. These centers in the cord are probably not specific heat centers, in that they send out specific heat fibers which regulate oxidation, but it is probable that these centers do have general control over such structures as the liver, etc., where heat energy is generated by oxidation. Howell states that "The unconscious regulation of the body temperature is effected chiefly through the following centers:

- |                  |   |   |
|------------------|---|---|
| Heat dissipation | } | <ol style="list-style-type: none"> <li>1. The sweat centers and sweat nerves.</li> <li>2. The vaso-constrictor center and the vaso-constrictor nerve fibers to the skin.</li> <li>3. The respiratory center.</li> </ol> |
| Heat production  | } | <ol style="list-style-type: none"> <li>1. The motor nerve centers and the motor nerve fibers to the skeletal muscles.</li> <li>2. The quantity and character of the food as determined by the appetite."</li> </ol>     |

**Relation of Temperature to Environment.**—The temperature of the surrounding medium is responsible to some extent for the temperature of the animal, its body heat production and loss of body heat. Homeothermous or warm-blooded animals maintain a rather constant temperature, the normal variations ranging within narrow limits. For man the possible variation is not more than 24° C., and this is uncommon. Starling states that in case of exposure individuals have recovered from a temperature of 24° C. The highest temperature that can be borne by man varies with many conditions, but it may be said that 44° C. is the highest limit, and few cases ever recover from this temperature. That the temperature of warm-blooded animals is largely independent of environment is shown by the fact that seals and other mammals living in frigid regions maintain a constant temperature equal to that of the human.

In poikilothermous or the so-called cold-blooded animals, the temperature is variable and is determined largely by the temperature of the surrounding medium. In these animals changes in their environment cause changes in their internal temperature,

and because the rate of chemical change in the body (metabolism) varies directly with the temperature, any reduced external temperature materially reduces the rate of oxidation and their heat-generating apparatus is reduced in activity. Their muscular and other body activities are also reduced, and the animal becomes inactive. Their heat-regulating mechanism is also very incomplete.

**Normal Temperature and Fever.**—The normal temperature of the human is about 37° C. or 98.6° F. when taken under the tongue. These figures are subject to variation and can only be taken as an average.

**Physiological Variation.**—The temperature of most individuals shows a daily variation, being highest in the afternoon and lowest in the early morning, varying from .1° C. to .5° C. during this time. The cause of the low morning temperature is rest and decreased metabolism, and the activity during the day with increased metabolism is responsible for the increased afternoon temperature. In those who work during the night and sleep during the day this order is reversed. Active muscular exercise may increase the temperature to as much as 100° F., but it soon becomes normal after rest. Exposure to heat or cold may also cause slight variations.

As stated above, the body is capable of only slight temperature variations, and any marked increase or decrease from the normal is accompanied or followed by abnormal symptoms. An increase from 38° C. to 40° C. (100° to 104° F.) is always followed by symptoms of fever, and an increase above 40° C. nearly always results in loss of consciousness. No fixed point can be set as the "death mark," but the maximum limit is seldom if ever higher than 44° C.

**Fever.**—The term fever is applied to that abnormal condition of the body characterized by an abnormal increase in body temperature, quickened pulse, thirst, abnormal metabolism, headache, etc., and is usually caused by some abnormal condition of metabolism or of the nervous system which disturbs the normal heat-production or dissipation.

Fever is most commonly due to abnormal or foreign substances in the blood stream known as toxins. Toxins may result from: 1, abnormal metabolism and the failure of the excretory organs to eliminate waste products, or they may be, 2, bacterial in origin. Toxins produce fever in one or more of the following ways: 1, by direct tissue stimulation, causing excessive metabolism beyond the power of elimination; 2, by disturbing the regulating mechanism of certain nerve centers which regulate body temperature; 3, by directly stimulating the heart or its nerve centers, causing excessive functional activity of that organ, or by, 4, decreasing the functions of the organs of elimination.

**Osteopathic Significance.**—The physiological principles underlying thermogenesis, or heat production, and thermolysis, or heat dissipation, should be well understood and it should be known that any factor which increases the former without a corresponding increase in the latter will surely result in an abnormal increase in the body temperature, or fever.

It is known that the body contains within itself adjusting mechanisms for the regulation of temperature, and that normal structural relations will be followed by normal temperature adjustment. It is known that there are certain so-called thermogenic centers in the cord and brain, and that disturbance of these centers results in inability to maintain normal body temperature.



# SECTION V

## INTERNAL SECRETIONS



## CHAPTER XXIII.

### GENERAL CONSIDERATIONS.

The functions of the skin as a receptive surface for afferent nerves which by their reflex association regulate the functions of internal structures to the external environment has been given, but there is another and in some respects a more effective way in which the various body activities are regulated, namely, by the secretions of the ductless glands. The name internal secretions has been given to the products of those glands which empty their secretions into the blood or lymph to differentiate this product from those secretions which are emptied into the alimentary canal or to the exterior through the skin and which are therefore properly termed external secretions.

In some animals and plants, particularly the lower forms, this inter-relation of function, because of the total lack or inefficient system of nerves, is almost wholly regulated by chemical methods. Certain cells and cellular substances seem to exhibit specific chemical attractions in body fluids which serve important functions in the body. This specific quality, organo-chemical attraction, is known as chemotaxis, an example of which is the attraction of leucocytes to an inflamed area of the body or to bacteria. In lower forms of life, the protozoa and some metazoa, it may be said that the correlation of the body functions are almost altogether regulated by such a chemical mechanism.

In the higher forms of life with the many intricate special functions and the widely differentiated structures for the performance of such functions, the complicated, highly differentiated, and specific nerve connections by reflex activities do much to correlate the functions of various structures, yet the influence of internal secretions plays a very important part. It has been



shown how the liver and the pancreas are stimulated to activity by secretin, a duodenal hormone, and we may consider the action of all internal secretions as being produced in a similar way. Some authorities hold that every structure in the body produces a secretion which influences some other structure or structures in the performance of their normal functions. "In one sense we may say that every cell in the body is chemically connected with and dependent on all the other cells in the body. This interdependence is a necessary consequence of the differentiation of function associated with increased complexity of the organism." (Starling.) Bayliss and Starling by their work on hormones have perhaps done more to establish these physiological facts than any other workers in recent years.

As evidence of how various tissue cells influence the functions of other structures Starling gives the following examples: 1. Food stuffs partially digested, secretagogues, etc., to all body tissues; 2. Glycogen of the liver is supplied to all structures in need of glycogen as it is demanded; 3. Urea, produced by all tissues, when carried to the kidneys serves to excite excessive elimination by stimulating kidney cells;  $\text{CO}_2$  produced by tissues from internal respiration on its way to the lungs to be excreted excites the respiratory center, causing increased respiration. The adaptation of this mechanism to the demand of function, that of increased oxygenation of the blood by increasing respiration, can be readily seen; 5. Protection of other tissues by specific excretory function of certain structures, such as the function of the liver in taking ammonia from the alimentary contents and converting it into urea, thus protecting other structures from the injurious effects of ammonia if it should be circulated in the body fluid.

Those substances termed chemical messengers or hormones, according to Starling must conform to certain requirements, as follows: 1. "They must not be antigens, i. e. their injection into the blood-stream must not evoke the production of an antibody. If this were the case, the hormone, on entering the blood-stream, would meet its antibody and would be unable to exert any effect on the appropriate reacting organ"; 2. "Since they must be

carried by the blood-stream to the reacting organ they must in most cases be susceptible to easy passage through the walls of blood-vessels if they are to excite a reaction within a fairly short space of time. This consideration would also tend to keep their molecular weight comparatively low." 3. "As a rule the chemical messenger must excite a state of activity in response to a change in some other part of the body. When the primary change passes away, the action of the hormone should also disappear. On this account it is necessary that the hormone should either be susceptible of easy destruction, by oxidation or otherwise, in the fluids of the body, or be readily excreted, so that its action may not be continued indefinitely." (Human Physiology, Starling, 1912 ed.)

**Methods of Study.**—Because these glands have no ducts and therefore their secretions cannot be collected for study as other secretions are studied, different methods must be employed. The methods most commonly used are given here:

**EXTIRPATION.**—By removing the structure from a normal animal by means of an aseptic surgical procedure and observing the abnormal symptoms which follow the extirpation, much may be learned concerning the function of such structures. Extirpation may be either partial in which only a part of the structure is removed, or complete removal of the whole.

**TRANSPLANTATION.**—After extirpation of certain glands the symptoms may be relieved or in some cases seem to entirely disappear if similar glandular substance from another animal of the same species is replaced in the animal in such a way that a blood and nerve supply may enter it. It is sometimes necessary to make the transplantation before or at the same time the gland is removed, as, in case of the pancreas for example, death will often result before the transplanted glandular tissue has had time to become sufficiently functional to maintain life. It seems to make little difference with the glands of internal secretion as to what part of the body they are transplanted. Again, as in case of the pancreas, it is not necessary to transplant the whole gland to prevent the symptoms, as a very small portion will often suffice.

**FEEDING OF EXTRACTS.**—Extracts of the glandular structures are prepared by grinding the structure. In some cases the whole gland is fed and in others only certain parts of the gland, or its extracts, made by dissolving the ground gland in water, glycerine, or some other solvent.

In some instances after extirpation, the feeding of these extracts materially relieves the symptoms which have resulted from the lack of the influence of the secretion of the extirpated gland. Therapeutically the feeding of such extracts has seemed to be of some value in the treatment of individuals suffering from undeveloped or atrophied glands. In many cases, however, this method of treatment is not followed by encouraging results.

Intravenous injection of chemical extracts made from these glandular structures is also used to determine the immediate effects on the system. In many cases, as explained above, the action of such secretions necessarily extends over a limited space of time, and by this method such changes can be determined. In some cases other methods of study are employed, which will be described elsewhere.

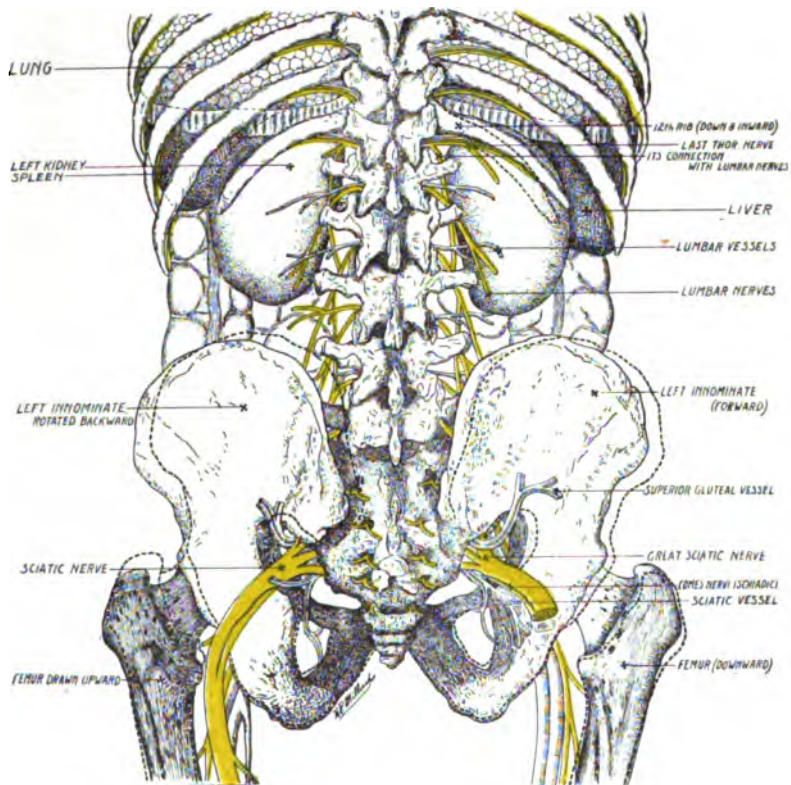

PLATE XXIII.—This plate shows the kidneys, liver, and lungs and their bony relations. One rib is shown in lesion and the relation of the nerve to the lesioned rib is also shown. The dotted lines indicate the abnormal position of the innominates in relation to the sacrum. The right innominate is thrown forward, lengthening apparently the right leg. The left innominate, the reverse. Slipped innominates, from wrenches, sprains, falls, or twists, are found existing in patients in our everyday practice, and correction of these innominate lesions results in the returning to a normal condition of the disturbed organs and tissues.



## CHAPTER XXIV.

### PHYSIOLOGY OF THE DUCTLESS GLANDS.

It is now quite generally accepted that certain glandular structures such as the pituitary body, the thymus, the adrenals, the thyroids and parathyroids, the spleen, the chromaffin bodies, and possibly other structures function only as organs of internal secretion, while many other structures such as the pancreas, kidneys, liver, ovaries, testes, duodenum, stomach and lymph glands, which are known to have other functions, also produce important internal secretions.

**The Pancreas.**—The external secretions of the pancreas have been given. The internal secretion, that which is emptied into the blood, is entirely a different substance, both as to origin and function. This secretion is probably produced by the islands of Langerhans of the pancreas. (See Series No. 4.) That there is an internal secretion of the pancreas which is altogether different from its external secretion, is clearly shown by the following experimental findings: The duct of Wirsung may be so attached to the abdominal wall that the secretion is emptied to the exterior, the animal thus deriving no benefit from such secretion. In such animals if care be taken to not give too much fat in the diet the animal does not suffer. The same thing has been shown by ligating the pancreatic duct, plugging it with paraffin, etc.

If, on the other hand, the pancreas is extirpated, severe symptoms soon follow: Glycosuria, even on a strictly noncarbohydrate diet; an increased quantity of urine, polyuria; an increased quantity of urea; abnormal hunger and thirst, and other less important symptoms. If partial extirpation be performed, leaving one-fourth or even a smaller part of the gland, the animal may live,

but the above symptoms with emaciation and death follow complete extirpation in a few weeks. Transplantation of a small part of pancreas in the abdominal cavity or beneath the skin of the suffering animal relieves the symptoms.

In the human it is now almost as common to associate the disease diabetes mellitus with some abnormality of the pancreas as it is to associate mental affections with brain disorders. In diabetes the same symptoms, viz., glycosuria, polyuria, emaciation, etc., as are found to follow extirpation of the pancreas in other animals are common. In most cases of diabetes certain pathological changes may be found in the pancreas at autopsy.

**Osteopathic Significance.**— We have shown in Series No. 4 that glycosuria, lasting for several months, may be produced in normal animals by artificial bony lesions of the mid-dorsal region of the spine. These animals showed other symptoms of diabetes, and while the percentage of sugar elimination was not great in all cases it must be remembered that these animals were only kept for a few months and the disease diabetes often requires years for development of the severe symptoms. Another explanation of the comparatively mild symptoms in these dogs is that they received the best of care during the period of lesion.

In our series No. 12, we have shown that glycosuria can easily be produced in monkeys by artificial bony lesions, and that the correction of these lesions is followed by relief from the symptoms and an increase in the animal's weight.

In the human it has been shown clinically by a great many osteopathic physicians that lesions of the mid and lower dorsal regions are found in diabetics, the correction of which is followed by relief from the symptoms.

Pathological conditions of the pancreas following vertebral lesions have been found by McConnell and by McBeath in our series No. 12.

### THE ADRENAL BODIES.

After complete extirpation of these glands in animals death results in a few days and, indeed, death may occur in a few hours. (12 to 24 hrs.—Starling.) The symptoms developing after extirpation are muscular weakness, loss of vascular tone, and prostration. The symptoms in animals resemble those in Addison's disease, a disease of the human showing the above symptoms, together with the bronzing of the skin and vomiting, and is found to be associated with pathological conditions or atrophy of the adrenals

The results of injection of the aqueous extracts are slowing of the heart-beat when the vagi are intact and an increase in blood pressure, but the increase in blood pressure is only of short duration. A chemical substance, adrenalin, which can now be prepared synthetically, is known to be responsible for the increase in blood pressure. This substance is active in very small quantities, "One four-hundredth of a milligramme per kilo body weight sufficing to evoke a definite rise of blood pressure." (Starling.) The rise of blood pressure is sudden and is accompanied by slowing of the heart-beat. After section of the vagi the injection of adrenalin is followed by a much greater increase in blood pressure. Starling states the results following the injection of the adrenalin as being practically the same as the functions of the spinal autonomies, viz., vaso-constriction, cardio-acceleration, pupillo-dilation, etc., but these effects are followed by paralysis of the vaso-constrictor fibers and therefore vaso-dilation follows the injection of over-doses.

There is another function, that of neutralization of certain poisonous substances which seem to affect the neuro-muscular system. These detoxicatory substances produced by the adrenals were shown by Langlois, who found that the blood of frogs after the removal of the adrenals was toxic to other frogs.

It seems that the activity of these glands can be increased by the stimulation of the spinal autonomies. If their secretion is so regulated it would seem highly probable that their functions



might easily be influenced by spinal lesions. If, as we have clearly shown, the functions of the kidneys can be affected by spinal treatment, there is good reason to believe that these glands may also be similarly influenced.

Adrenalin is frequently used in minor surgical operations as a hemostatic to prevent hemorrhage, but because its effects last only for a few minutes the injections must be frequently repeated.

**Osteopathic Considerations.**—These structures are well supplied with blood, and probably no other structures receive a richer nerve supply from the spinal autonomies. Since we have shown that many other structures so supplied can be affected by spinal lesions and spinal treatment it is not unreasonable to suppose that these glands may be so affected. McConnell has found congestion of these glands in animals following bony lesions.

### CHROMOPHILE BODIES.

It is known that other small bodies which resemble the medullary substances of the adrenals histologically and in staining characteristics are found in other parts of the body. In some animals many accessory suprarenal bodies are found, and in man such bodies are found in association with the autonomic ganglia. The secretion of these glands is probably very similar to, if not the same as, chromaffin or epinephrin produced by the medullary portion of the adrenals. Extracts when injected increase blood pressure. It is generally supposed that degeneration of these structures, like degeneration of the adrenals, is in some way associated with the condition known as Addison's disease.

### THE THYMUS GLAND.

**Results of Extirpation.**—If the thymus gland be removed early in life there seems to be an overgrowth of the testes or ovaries, and the converse is also true, viz., that after castration or ovariectomy in the young individual the thymus seems to grow larger. There seems to be, therefore, some "reciprocal relationship"

(Howell) between these structures. The fact that the thymus gland reaches its maximum of growth at or about the age of puberty and from that time on seems to atrophy and become functionless is further evidence of this relationship.

Many other theories have been advanced concerning the functions of the thymus, as follows: 1. That this gland is associated in some way with growth and development during early life; 2. That it produces some secretion which influences the normal tone of the nervous system; 3. That it influences normal metabolism in some unknown way, such that thymectomy often results in malnutrition and death.

The extract when injected seems to cause a decrease of blood pressure and an increase in heart beat.

### THE OVARIES AND TESTES.

These organs are not usually classed with the ductless glands, as they have other essential functions, viz., in case of the ovaries, that of producing the female reproductive cells, the ova, and in case of the testes, that of producing the male reproductive cells, the spermatozoa; but it is known that they have other functions and that they produce useful internal secretions.

**The Testes—Effects of Castration.** — Emasculation never causes death. Whether the operation is followed by diminished physical power is yet undetermined. There is experimental evidence to show that the internal secretions of the testes increase oxidation.

**Effects of Extracts.**—Injection of extracts 1. increases both physical and mental activity; 2. increases systemic oxidation; (This is possibly the cause of the increased power to do work.) and 3. it increases the activity of the spinal centers and reduces the sensation of fatigue.

The following functions may be attributed to the internal secretions of the testes: 1. Regulation of developmental changes before and after puberty; 2. Oxidation of certain food substances, which probably increases physical and mental energy; 3. They

may produce a detoxicatory substance which neutralizes certain body toxins.

Some authorities, Lorand and others, state that if castration be performed before puberty the subjects never develop masculine characteristics and are less intelligent, and that the same is true of those whose testicles do not develop. There is also some reason to believe that those men whose testicles are well developed, other things being equal, are capable of greater physical and mental energy.

**The Ovaries—Effects of Extirpation.**—Ovariectomy in animals is followed by 1. an increase in fat, 2. cessation of menstruation ("heat" in animals), and 3. a decrease in muscular and sometimes in mental vigor. In women the same changes occur after ovariectomy, and the premature menopause is often followed by distressing physical and mental symptoms which may be relieved in some cases by injection of extracts, feeding of extracts, or by grafting of ovarian tissue into the body. In dogs after ovariectomy the "heat" may be re-established by a transplantation of ovarian tissue under the skin, and the condition of menstruation can be produced in virgin animals by the injection of ovarian extract made from the ovaries of a pregnant animal. It seems, then, that we have an example of a nervous reflex function caused by a chemical agent.

The fact that women after the menopause usually get heavier and the fact that the same results follow after ovariectomy is evidence for the belief that the internal secretions of the ovaries prevent the laying on of fat, and in case of the ovaries and testes this is probably due to the lack of some agent whose purpose is the oxidation of fats.

### **THE PITUITARY BODY.**

This structure consists of two parts, the anterior or glandular portion and the posterior or nerve portion. These two parts are histologically and embryologically different. The functions of this structure are yet very questionable, not because little

work has been done to determine its function, but because of its location making successful experimentation, especially extirpation, very difficult.

**Results of Extirpation.** (Cushing's results.) — Section of the stalk seems to cause no effect, but removal of the glandular portion results in death in two days. These symptoms are that of a slow, chloral-like poisoning. Other workers claim that these results are of no significance because all animals died and that the death may have been due only to the operation.

Extracts of the gland when injected into the normal animals (Shafer and Herring) produce vaso-dilation of the vessels of the kidneys and excessive secretion of urine. These extracts also cause pupillo-dilation and probably affect the spinal autonomies. Other viscera, the uterus, bladder, and so on, are also affected.

The disease acromegaly, characterized by an overgrowth of bone tissue, was found by Marie to be associated with certain changes in the pituitary body. This excessive growth of the long bones due to the degeneration of the pituitary body is the cause of most of the cases of **giantism** commonly exhibited.

The following functions have been ascribed to this structure through its internal secretions: 1. Regulation of secretion of the kidneys; 2. Regulation of the growth of bone tissue; 3. Some functional relationship exists between this structure and the thyroids, as this gland becomes more active after thyroidectomy; 4. Its secretions play some part in carbohydrate metabolism, but it probably has just the opposite function of the internal secretions of the pancreas. The less the secretion of the pituitary body the greater the tolerance for carbohydrates. The above functions are probably associated with the posterior lobe, the secretions of which seem to be emptied chiefly into the cerebro-spinal fluid.

### **THE PINEAL BODY.**

There is little known about this structure other than that it is probably a vestigial remnant of a primitive eye. In childhood it is glandular, but soon atrophies.

**Possible Functions.**—It may have something to do with growth, but this is not probable. Extracts when injected are said to produce slight vaso-dilation. It may bear some relation to the development of the reproductive glands.

### THE THYROIDS AND PARATHYROIDS.

These two structures are so closely related embryologically and anatomically that it is difficult to determine whether they have separate and independent functions.

**Results of Thyroidectomy.**—Extirpation of these glands causes the most marked symptoms in carnivorous animals and less marked symptoms in the herbivora. Likewise after thyroidectomy the greater disturbance results from the feeding of a meat diet.

Complete thyroidectomy is usually followed by death in from one to four weeks. After the operation certain symptoms such as muscular tremors, convulsions, emaciation, and cachexia result. Atrophy of the thyroids in young individuals is accompanied by lack of development both physically and mentally, which condition is known as cretinism. In the adult degeneration of the glands is followed by the disease known as myxedema, which is characterized by edema of the skin and mental disturbances. The deficient mentality in young individuals following atrophy or thyroidectomy is probably due to the lack of brain development rather than any lack of function of the internal secretions.

**Results of Extracts.**—Extracts of these glands are prepared for feeding purposes in case of atrophy of the glands. These results are often unreliable because of the impurity of the extracts used. Symptoms developing after thyroidectomy have been relieved by the feeding of extracts to animals. The value of the feeding of extracts in cretinism is yet questionable, but in cases of myxedema good results have been obtained.

**Transplantation.**—Grafting of thyroid tissue usually prevents the severe symptoms after thyroidectomy, and this method

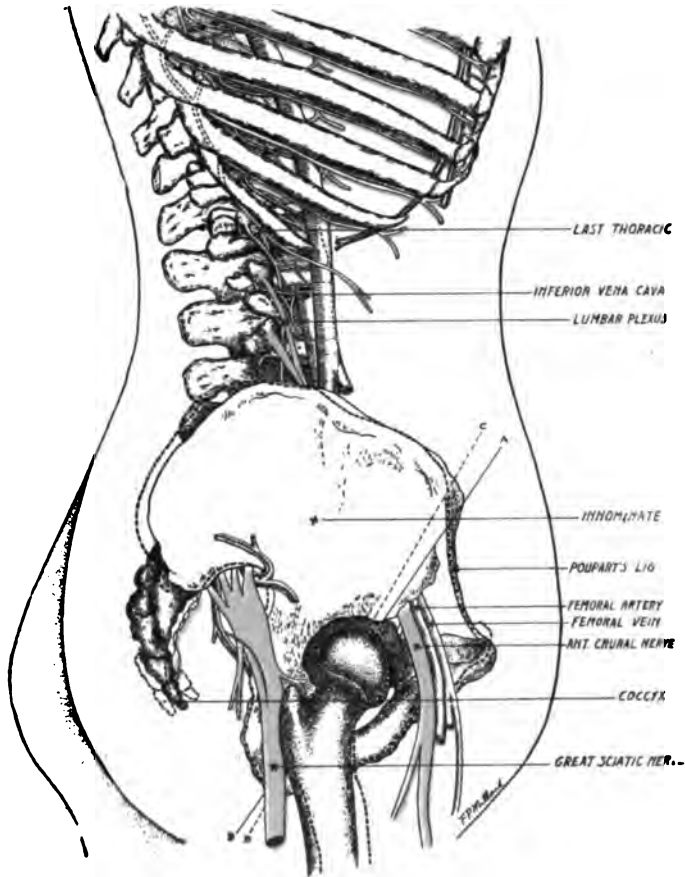

PLATE XXIV.—A lateral view of the bony framework is given in this figure showing the bony structures surrounding the liver and kidneys. The close relation of the nerve to the rib may be noted and it may be seen that lesions of the ribs could easily affect the nerves. The innominate is shown tilted backwards by a dotted line, raising the femur in the socket. The lines A, B, C, and D indicate the extent of the rotation of the innominate. When this condition exists we almost invariably find pelvic disturbances, as this bone assists in the formation of the pelvic basin. The correction of this subluxation tends greatly to restore to normal a varied number of disturbances which otherwise cannot be reached. See "Innominate Lesions" in Part II of this book.



has been used with some success in practical surgery in cases of myxedema and cretinism.

**Secretions.**—The substance of the thyroid upon chemical examination shows a greater iodine content than other body tissues, and it is supposed that iodine in some form is stored in these structures and given to the blood as needed. The active chemical substance produced by the thyroids is known as thyroiodin.

**The Parathyroids.**—It has been found that removal of the thyroids only, in certain animals is not followed by death or in some cases causes no severe symptoms, but if after thyroidectomy the parathyroids are removed, death results.

The parathyroids probably produce something which neutralizes toxic substances formed elsewhere in the body. They are probably also associated in some way with the calcium salts of the body, as Macallum has shown. Whether they have different functions from the thyroids is not yet known, but that the thyroids and parathyroids are themselves functionally related is known.

**Hypertthyroidism.**—Abnormal overgrowths, hypertrophy of the thyroids, or goitre, are of several kinds and are classified according to the nature of the growth and symptoms, which are probably a result of the secretions produced in excess.

These conditions are sometimes treated surgically by performing a partial thyroidectomy, after which the glands often continue to grow and the operation must be repeated. Because of the need of the secretion for body metabolism it is not advisable to perform a complete thyroidectomy.

## THE KIDNEYS.

As a gland of internal secretion it has been shown that extracts of the kidney when injected into the blood stream of a living animal produce an increase in blood pressure. It is also claimed that the kidney produces an internal secretion which influences metabolism, and it possibly also produces a diuretic secretion by means of which it activates its own function.





# SECTION VI

## CONTRACTILE TISSUE



## CHAPTER XXV.

### PROPERTIES OF CONTRACTILE TISSUE.

The contractile tissues of the body may be considered as muscle, ciliated epithelial cells, and those leucocytes which have the power of ameboid movement. The muscle tissue constitutes by far the greatest and most important of these.

**Ciliated Epithelium.**—Ciliated epithelium is found on the mucous membranes of the following structures: 1. Air passages, e. g., the trachea, the larynx, the bronchi, and the nasal passages; 2. the uterus, Fallopian tubes and epididymis; 3. the lachrymal duct and sac; 4. the Eustachian tubes; 5. the ventricles of the brain and spinal cord.

The movement of the cilia of ciliated epithelium consists of a slow movement in one direction, which is effective in carrying foreign substances on its surface forward or towards the outlet. Following this there is a quick movement backward, which separates the free surface of the cilia from the object being moved. By this series of movements the cilia are able to gradually carry out foreign substances such as dust particles, etc., and in this way in many of the structures such as the mucous membranes of the air passages, this movement serves an essential protective function. In the Fallopian tubes the movement of the cilia performs another function, that of carrying the ova to the uterine cavity. The cilia of the ventricles of the brain and canal of the spinal cord probably have no function. These structures are the results of infoldings of the ectoderm, which at one stage in the animal's phylogenetic development represented the outer part or peripheral cell mass, and their cilia were then functional as motile structures. These cilia in the mammals represent only vestigial structures.

The motility of leucocytes has been discussed elsewhere. The purpose of such movements is readily apparent in that their power of motion enables them to move to places where they are needed for protection against invading bacteria, etc. Their power of ameboid movement enables them to penetrate the walls of the capillaries and thus come in direct contact with various tissue cells. White blood corpuscles, especially the motile leucocytes, may be considered the primitive cells of the body retained for the performance of certain functions common to the amœba and similar cells. They have all of the primitive functions of protoplasm—reproduction, motion, growth, etc., and in addition they seem to have developed exceptionally well the power of ingestion of foreign substances. This is an example of how a demand for a certain function has played a seemingly strange part, in that in this instance, instead of causing a specific differentiation it has caused the retention of original characteristics.

This atavistic cell has, however, many important functions to perform and plays an important part in the body functions, just the same as the most highly differentiated and complex structures.

### PHYSIOLOGY OF MUSCLE.

Muscle tissue is considered under three classes, viz., striated or voluntary muscle, smooth or non-striated muscle, and heart muscle, each kind differing in structure and function in certain respects.

**Striated Muscle.**—Striated or skeletal muscle constitutes that which is concerned with the voluntary movements of the body. The fibers consists of single, large, multinuclear cells and lie in bundles which are known as fasciculi. Each fiber is inclosed in an elastic membranous sheath termed the sarcolemma. The sheath contains the semi-fluid muscle plasma and fibrils. The fibers are long, thread-like structures, extend longitudinally through the cell, and are surrounded by the sarcoplasm. These fibrils are striated transversely, which gives to the cell its name of striated muscle. The fibrils lie in groups known as

sarcostyles, which float in the sarcoplasm. These fibrils are generally considered to be the contractile elements of the cell.

**Heart Muscle.**—This type of muscle is found in the heart and in the diaphragm. It differs from striated muscle in that the cell contains a greater amount of sarcoplasm, which is granular and in some respects more nearly resembles undifferentiated protoplasm. Heart muscle differs from striated muscle in that the fiber is mononuclear, the nucleus being located near the middle of the cell; the cell is smaller, it has no sarcolemma, the cells are branching and irregularly arranged, and the transverse striations are not so distinct as in the striated fibers. Heart muscle differs from striated muscle functionally in that the rate of contraction is slower, its contractions are rhythmical, it is considered non-fatigable, it is said to contract equally, regardless of the strength of the stimulus, and is to some extent under control of the will power.

**Smooth Muscle.**—Smooth or involuntary muscle is found in the walls of the following viscera: It constitutes the musculature of the walls of the alimentary canal from the mid or upper portion of the œsophagus to the internal sphincter ani; it forms the musculature of the uterus and Fallopian tubes, the urinary bladder, the gall bladder and duct, the trachea and bronchi, the ducts of all glands, the seminal vesicles, the blood vessels and lymphatics, the intrinsic muscles of the eye (iris and ciliary muscles), the tunica dartos and the muscles of the skin.

The fiber is mononuclear, the nucleus lying near the center, and is striated longitudinally. It differs from the other kinds of muscle in the nature and structure of the cells, as stated, and differs functionally in that the rate of contraction is much slower than in either of the other kinds; the contractions are progressive but not necessarily rhythmical; like heart muscle it is practically nonfatigable because the contractions occur slowly, and like striated muscle the extent of contraction varies directly with the strength of the stimulus.

**Blood and Nerve Supply.**—The muscle fiber is supplied with blood by a meshwork of small capillaries about each fiber.

Smooth muscle is supplied by nerve fibers from the autonomic system only. Heart muscle is supplied by nerve fibers from the autonomic system and also by fibers from the central nervous system. Striated muscle is supplied by nerve fibers from the central nervous system only. The axis cylinder of the nerve fiber terminates in a motor end-plate which transmits the impulse to the muscle fiber, and the primitive sheath of the nerve fiber becomes continuous with the sarcolemma.

### GENERAL PROPERTIES OF MUSCLE.

**Elasticity and Extensibility.**—All muscle tissue is normally elastic and extensible. The muscle fiber may be made to extend by the application stress, but unlike non-living extensible substances the strain or amount of extension is not proportional to the stress or distorting force except within certain limits. If weight, for example, be applied to rubber the extension continues in proportion to the increased weight added. This is true of muscle tissue for a medium amount of extension, but, if continued, soon the limit of elasticity is reached and the muscle loses its power to retract. (Weber's paradox.)

Muscle tissue is normally in a state of constant tension, which is variable, depending upon the kind of muscle, the physiological state of the muscle, and the nature of the blood and nerve supply. If the normal amount of stimuli to the muscle fiber by way of the nerve fiber is decreased, the tension or tone of the muscle fiber is diminished, and if the amount of stimuli is increased the tension is increased. That muscle tissue is in a state of constant tension may easily be demonstrated by the shortening which immediately occurs when the tendon of a muscle is cut in a living animal.

The purpose of this constant tension is chiefly for the purpose of regulating normal voluntary movements. If, for example, a stimulus were sent quickly to a set of muscles with the intent of performing some regulated movement and the muscles stimulated were without tension, the quick contraction would result in a jerk instead of a regulated movement. There are, of course,

many other reasons why a certain amount of constant muscular tone is of value to the normal functions of the muscle, such for example as the dangers of over-strain, etc.

**Irritability.**—The cause of muscular contraction is ultimately the stimulus sent to the muscle by way of its efferent nerve fiber. Irritability may be defined as that property of muscle or other tissue by virtue of which it may be made to functionate as a result of stimulation, and the term "stimulus" is definable only in terms of irritability. Stimulus may therefore be defined as any influence which has the power of causing irritable tissue to functionate.

As evidence that nerve stimulus is the cause of normal tone and contractility in muscle it may be stated that, if the nerve to the muscle be severed the tone of the muscle is lost, paralysis follows, and the muscle tissue degenerates. On the other hand, if the end of the nerve leading to the muscle (peripheral end) be stimulated artificially, the tone of the muscle fibers is increased and contraction of the muscles quickly follows. The nerve is essential to normal muscle contraction by applying stimulus directly to the latter, but muscle to which the nerve has been sectioned cannot be made to contract voluntarily, and, if the nerve does not soon regenerate, atrophy in this case may be due to one or the other or both of two causes: First the atrophy of disuse, and second, the atrophy which results from the inability of the muscle to regulate its nutrition. This latter, the so-called trophic influence of the nerve, is not well understood. Whether the nerve actually changes in the muscle or whether, by affecting the blood supply or in some other way the nutrition is affected, is not known, but that the nerve is essential to normal nutrition and growth of the muscle has been positively established.

**Effect of Curare.**—Curare is a vegetable extract prepared from certain members of the Strychnos family and used by South American natives as an arrow poison. Alkaloids of this drug when injected into living animals destroy the action of the motor nerves to muscles by affecting the end-plates. The experiment is usually carried out by injection of solutions of the drug beneath



the skin of a frog. Direct stimulation now applied to the muscles of the curarized frog produces contraction of the muscles stimulated, but stimulation of the efferent nerve to the muscle produces no effect. This shows that the nerve is not essential to muscle contraction. If only a small amount of curare be used the effect soon passes off and the muscle may again be made to contract by stimulation of the motor nerve.

**Artificial Stimulation.**—For the purpose of studying the functions of various nerves and their power of regulation of various structures certain methods of stimulation artificially have been employed.

1. **MECHANICAL STIMULATION.** — Nerves may be stimulated mechanically by applying direct pressure to the exposed nerve trunk. Only a slight pressure is necessary to produce variations in nerve activity. If quick pressure be applied to a nerve trunk, such as pinching or by gently pulling or jerking, the effect is stimulation and an increase in the functional activity of the structure or structures supplied, if it be the peripheral end of the nerve. If such mechanical stimulation be applied to the central end of a mixed or sensory nerve the result is stimulation of the centers and is followed by reflex effects. If steady pressure be applied to a nerve trunk by pressure or by ligature the result is at first stimulation, but this is followed by inhibition or a decreased amount of stimulation, which in turn is followed by decreased activity of the structures supplied. Structural lesions such as contracted muscles, subluxated bones, or visceral lesions may be effective in causing such effects. This, however, is not the only explanation of the effects of osteopathic lesions.

2. **THERMAL STIMULATION.**—Nerve trunks and muscle tissue may be stimulated by the application of cold or heat to the structure. Only slight changes in temperature are necessary to produce variations in nerve stimulation. In the stimulation of nerve trunks by this method some hot or cold metallic substance is usually used, applying it directly to the nerve. Temperature stimulation may also be effected by dipping the nerve into cold

or hot water or by the application of hot or cold packs to the various regions of the body.

3. **CHEMICAL STIMULATION.**—By the application of various chemical substances such as weak acids and alkalis, strong salt solutions, etc., to nerve trunks, stimulation may be effected. If the chemical stimulant be left in contact with the nerve trunk for a length of time, or if strong solutions be applied, the result is inhibition. An example of this is the effect of  $\text{CO}_2$  on the conductivity of nerve fibers. If  $\text{CO}_2$  be passed around nerve trunks or cell centers they soon lose the power of conductivity. Oxygen, on the other hand, increases conductivity.

4. **ELECTRICAL STIMULATION.**—Electrical stimulation applied to nerve trunks or to various other structures by means of platinum electrodes from an induction coil (induced or faradic current) is most generally used for artificial stimulation. The advantages are that the strength of the stimulus can be regulated, it can be applied more directly to the part selected, usually affects all fibers of the nerve trunk equally, thus giving co-ordinated contractions, and, if the current is kept weak there is less danger of injuring the nerve than by other methods.

## CHAPTER XXVI.

### MUSCULAR CONTRACTION.

**The Simple Contraction.**—The shortening of a muscle which results from the effect of a single stimulus is known as a simple muscular contraction. The nature of such contractions is studied best by using the *gastrocnemius* of a frog in a moist-chamber apparatus. By this means, either by stimulation of the muscle directly or by stimulating the nerve to the muscle, the record tracing of the curve of contraction (contraction followed by relaxation) may be made on the smoked paper of a kymograph for the study of its component parts.

**Contraction Time.**—The length of time necessary for the shortening of muscle varies with different species of animals and with different muscles in the same individual animal. The following table from Howell gives a general idea of such variations:

#### DURATION OF A SIMPLE MUSCULAR CONTRACTION (Howell).

Insect .....	0.003 second
Rabbit (Marey).....	0.070 "
Frog.....	0.100 "
Terrapin.....	1.000 "

The series may be continued by the figures obtained from the plain muscle, thus:

The involuntary muscle (mammal) .....	10.00
Foot muscle of slug ( <i>ariolimax</i> ) .....	20.00

A little study of the significance of this table will reveal an example of the result of structural adaptation to the demand of function. The purpose of the quick movements of the insect muscle may be explained in the demand of such movements that the insect may escape its enemies. The same is true for the rabbit muscle, as this animal depends upon its speed for purposes of protection while the terrapin has another and much more

effective method of protection and there seems to be no real need of quickness of muscular activity.

Plain muscle requires from ten to twenty seconds for contraction, and here again it may be seen that there is a greater demand for slow, regulated movements (peristalsis of the gut, for example) than for quick movements.

In the contraction curve it may be seen that the muscle does not begin to contract at the very instant of the application of the stimulus, but that the shortening actually begins a short time after the stimulus is applied. This period of time which elapses between the time of the application of the stimulus and the beginning of contraction is known as the "latent period." In frog muscle this is equal to about .01 second and is probably due to inefficiency of the apparatus, or elasticity of muscle tissue. Some time is necessary for the chemical changes which initiate contraction, and time is actually necessary for the beginning of the shortening of the muscle after the chemical changes have occurred.

The contraction curve is divided into two parts, called phases. They are the phase of shortening, about .04 second, and the phase of relaxation, which is about .05, making the total time of the contraction wave about .09 second.

**The Latent Period.**—The muscle does not begin to shorten instantly after the application of the stimulus to the nerve of a muscle, but a short period of time always elapses, about .01 second, which, correcting for errors of the apparatus used, may be greatly reduced. This period of latency is probably due for the most part to the time required for the occurrence of the chemical changes necessary for the production of the energy. Other factors, such as elasticity of the muscle, inertia of the muscle, and load to be lifted, also tend to retard contraction.

The period of latency is not constant, but varies for different muscles and for the same muscle under different conditions, such as temperature, tone, condition of fatigue, etc.

**Conditions Affecting Muscular Contraction.**— There are various conditions which may influence the nature of muscular contractions:

1. Temperature variations affect muscular contractions in a peculiar way. In case of the frog the muscle loses its irritability at about  $0^{\circ}$  C. From this temperature the irritability increases up to about  $9^{\circ}$  C. and decreases as the temperature is increased up to about  $17^{\circ}$  C. From this temperature the irritability increases again as the temperature is increased until a temperature of about  $30^{\circ}$  C. is reached. Beyond this the irritability decreases up to about  $37^{\circ}$  C., when the contraction ceases. In most striated muscle there is a certain optimum temperature for muscle contraction, which is about that of the normal body temperature of the animal and a maximum temperature above which muscle will no longer function. The maximum temperature for muscles of most mammals is from  $43^{\circ}$  to  $45^{\circ}$  C. Proto-plasm cannot withstand high temperatures and, generally speaking, no tissue can maintain its functional activity above  $45^{\circ}$  C.

The functional activity of all tissues seems to increase as the temperature increases up to a certain limit. For homeothermous animals this limit is from  $40^{\circ}$  C. to  $45^{\circ}$  C.

2. Muscular contraction varies also with the strength of the stimulus applied. If the stimulation apparatus, an induction coil, be so arranged that a light stimulus may be discharged to a muscle-nerve preparation and the result recorded on the smoked paper of a kymograph and, after allowing a period for rest, a stronger stimulus is applied the increased amount of shortening may be measured. It may thus be shown that, other conditions being equal, the amount of shortening (contraction) varies directly with the strength of the stimulus.

**Contracture of Muscle Tissue.** — Contracture may be defined as a condition of maintained contraction or as a condition of retarded relaxation. The muscle becomes very rigid and the power of relaxation is temporarily lost. This condition must not be confused with the simple muscular contraction.

**Causes of Contracture.**—1. If a muscle be caused to function excessively either by the application of artificial stimuli rapidly repeated or by excessive work from normal stimulation, such as a long continued lifting of a load, which in either case may

cause fatigue, the condition of contracture may result; 2. Quickly applied stimuli are often a cause of contracture. This may be shown experimentally by suddenly throwing a strong electrical stimulus into the nerve to a muscle, as in a muscle-nerve preparation. The same condition sometimes occurs in athletes who try to make an unusually sudden and vigorous movement; thus the need of the so-called "warming-up exercises" before the race. If the muscles are gradually exercised they become much more receptive to the effects of strong stimuli. The occurrence of "cramps" may be explained in this way, the excessive stimulation of cold water or, as explained above, the unusual attempt to perform some muscular movement may serve to overstimulate the muscle; 3. Contracture as a result of rapidly repeated stimuli may be demonstrated by sending a series of stimuli into a muscle-nerve preparation. The apparatus must be so arranged as to electrically stimulate the muscle very rapidly. The condition of contracture which results may last for several minutes.

**Tetanic or Compound Contractions.**—Tetanus of muscle may be defined as a condition of maintained contraction resulting from a series of rapidly applied and continued stimuli. It may be thought of as a long lasting condition of contracture. The various conditions mentioned above as cause of contracture may also be causes of tetanus. The application of rapidly repeated stimuli in such a way as to cause the muscle to begin a second contraction before the effects of the first is lost, thus allowing no time for relaxation, explains the mechanism of tetanus.

If the stimuli are not rapidly applied, but continuously repeated so the muscle slightly relaxes between the stimulations, complete fatigue will not occur for a longer time and, if the stimulation be stopped, the muscle quickly recovers. This condition is known as incomplete tetanus.

If the stimuli be more rapidly repeated and continuously applied the muscle shortens and remains shortened with no relaxations between the application of the stimuli. This condition is known as complete tetanus. A continuous repeated stimulation of 300 per second is necessary for the production of a condition

of complete tetanus. The rate of stimulation for complete tetanus varies for different muscles and other conditions, such as temperature, etc.

In complete tetanus of a muscle, the tracing of which shows no variation, it may be shown that each separate stimulus produces its own independent effect and that chemical changes occur for each contraction. The discontinuous nature of the tetanus may thus be shown.

**Pathological Tetanus.**—The disease tetanus, in animals and human individuals commonly known as lockjaw, is caused by one of the toxins of *B. tetani*, tetanospasmin. This toxic substance when injected into an animal produces symptoms of tetanus (contracture of muscles) in from twelve hours to three days, the time varying with the dose used. The musculature involved becomes tense and occasionally spasmodic contractions occur until the disease progresses to the stage where complete tetanus obtains. The symptoms in tetanus are brought about by an increase in the reflex activity effecting an increased excitation of the motor nerve cells of the spinal cord, medulla, and pons. The muscles first involved are those nearest the point of inoculation in most cases, the condition spreading to other groups of muscles until before death the entire body musculature may be affected.

**Summation.**—A condition known as summation of stimuli may be effected by causing a second stimulus to pass into the muscle before the effect of a first stimulus is lost. If, for example, the muscle be stimulated a second time at the end of the first phase of a simple muscular contraction a second and higher rise in the muscle curve will result.

The amplitude of the second curve varies with (1) the strength of the second stimulus, the amount of the contraction increasing as the strength of the stimulus is increased; (2) the amplitude of the second contraction also varies directly as the interval between contractions and (3) varies inversely as the load on the muscle.

The above phenomena show that the muscle ordinarily does not contract to its maximum of capacity and that a second or

continued series of contractions is possible and may be regulated by the amount of stimulus applied.

In the mechanism of voluntary muscle contractions, to be discussed later, the increased power of shortening due to increased stimulation explains the regular and continuous shortening of the muscles in voluntary movements.

**Treppe.**—If in the muscle-nerve preparation a series of slowly repeated stimuli be applied to a muscle and the amount of shortening be recorded on a kymograph, it will be noted that each stimulus is followed by an increased amount of shortening. This is the so-called staircase effect or "treppe." It is due to the increased irritability of muscle after a series of moderate stimuli. The result shows the increased functional activity caused by a gradually increasing susceptibility of muscle tissue to nerve stimulus.

**The Contraction Wave.**—If in case of an isolated or curarized muscle a stimulus be applied directly to one end of a suspended muscle, a wave of contraction may be seen to move over the muscle from the point of the application of the stimulus. The wave so produced affects the fibers, causing contraction in them as it progresses through the muscle. The velocity of the contraction wave in human muscle is from ten to thirteen meters per second and from three to four meters per second in frog muscle.

This kind of contraction does not occur in normal physiologically active muscle. There is a special provision for the equal stimulation of all muscle fibers at one time. The motor end plate being situated at or near the central portion of the muscle fiber provides for the equal stimulation of all fibers, and thus the contraction wave is prevented. Contractions occurring in muscle from normal nerve stimulation are a result of the effects of a generally applied stimulus to all fibers, they contracting in unison and in the same phase.

**Idiomuscular Contraction.**—Idiomuscular contraction is the local contraction due to the application of a local stimulus. It may be demonstrated in dying muscle or pathological muscle by stroking or otherwise locally stimulating the part.



**Nature of Voluntary Contractions.**—By comparing the time of voluntary contractions with the time of a simple muscular contraction it will readily be seen that the latter is far too short to explain the nature of most voluntary movements. Voluntary movements are therefore most likely tetanic in nature and are caused by a gradually increasing amount of stimulus supplied by the efferent or motor nerve to the muscle.

**The neuro-muscular mechanism consists of the following various parts:** 1. The upper motor (pyramidal) neuron extending from the higher or cortical centers to the anterior (motor) horn cells of the various parts of the cord. Its function is association and regulation of the functions of the motor cells of the cord; 2. The lower motor (spinal) neuron extends from the cord to the muscle and supplies nerve energy for the initiation of muscular contraction. These two fibers constitute the pathway by means of which the stimulus passes from the cortical and cord centers to the active muscle.

An average of about ten impulses per second are sent to muscle by way of the motor nerve for purpose of causing normal muscular contraction, which is continued during the entire time the muscle is thus functioning. If at any time during the contraction the action needs to be increased the amount of stimulus is correspondingly increased. The normal muscular contraction therefore consists of a series of single contractions which result in the gradually increasing and regulated movements, and during this period the muscle is in a state of controllable tetanus.

During the period of contraction if a stethoscope be applied a sound (muscle tone) may be heard, which is thought to be produced by the contracting fibers. These tones vary from thirty-five to forty per second. This rate is generally thought to be too high and that the rate of vibration is much lower than this. Since the human ear cannot detect sound vibrations lower than forty per second, it is likely that the sounds heard are overtones of the lower and inaudible tones.

## CHAPTER XXVII.

### NORMAL FUNCTIONS OF MUSCLE TISSUE.

**Methods of Study of Voluntary Contractions.**—Various methods have been employed for the study of voluntary contractions in animals and in man, some of which will be given.

**The Ergograph.**—The ergograph is an instrument so constructed that the forearm is held firmly fixed in an arm rest while the middle finger is gripped into a stirrup attached to a weight-

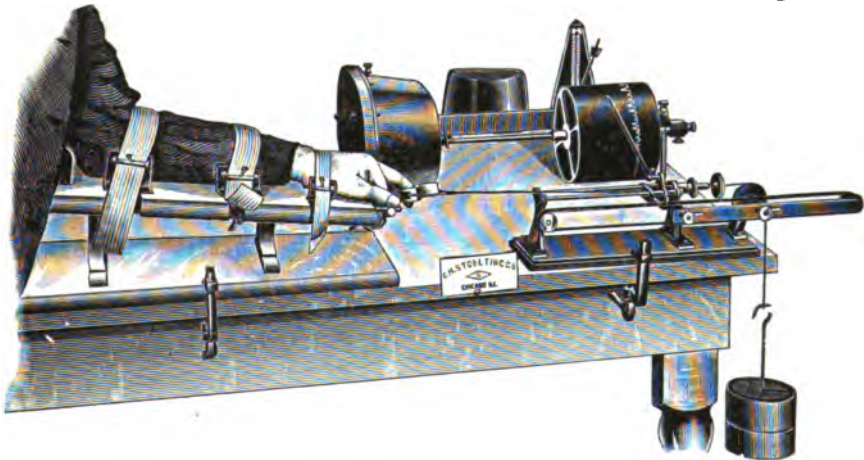

FIG. 23.—THE ERGOGRAPH.

lifting device. By this means the functional powers of the flexor sublimus digitorum muscle may be studied. A tracing pointer from the apparatus is extended to a kymograph for recording the results.

The conditions necessary for the study of muscular work by this means are: (1) The other parts of the arm must be held immovable and only one muscle or a single group of muscles

allowed to act in lifting the load; 2. The weight must be known and adjusted to the relative lifting power of the muscle; 3. The weight must be lifted through a definite distance at each contraction, that the total amount of work done may be calculated; 4. The contractions must be effected at regular intervals, thus not allowing long periods of time for rest. Under these conditions much may be learned concerning the functional activities of muscle, but there are yet many sources of error. After the muscle has undergone complete fatigue from the lifting of a heavy weight it may still be able to lift a lighter load. The total amount of possible work of a muscle cannot, therefore, be accurately determined by this method.

Muscular fatigue may well be studied by this method and the results of such an experimental study furnishes some interesting information, as follows: 1. That if sufficient length of time be allowed for rest between contractions fatigue does not result. This fact would tend to confirm the theory that while functioning the muscle actually uses energy which is quickly restored if the muscle be allowed to rest. This restoration of energy is effected chiefly by the carbohydrates of the blood and the glycogen content of the muscle. If sufficient load is used and the muscle is made to contract without allowing periods of rest, fatigue results. The length of time necessary for complete fatigue varies inversely with the load and directly with the length of time allowed between contractions. After complete fatigue a period of about two hours is required for restoration of the muscle. After complete fatigue, any attempt to contract the muscle prolongs the period of restoration to functional activity. These facts show that fatigue and over-stimulation of muscle is injurious.

There are many other factors which affect functional activity of muscle, as may be shown by the ergograph. It may be shown that anything which injures the general nutrition and health, such as the loss of sleep, lack of food, anemia, etc., reduces muscular power. Mental activity also reduces muscular power and this fact seems to show that surely a definite amount of body energy, which may be called nerve force, is used in mental activity.

Anything which improves the general circulation, such as massage, increases muscular energy; and anything which interferes with the circulation to a muscle or group of muscles reduces the muscular power. Muscular energy may be increased by the feeding of foods which are readily absorbed, such as the soluble sugars. The use of one set of muscles decreases the muscular power of all. This may be shown by doing some kind of work with the musculature of another part of the body, while one set of muscles is doing work on the ergograph. The absolute power and the length of time of fatigue are both reduced. This and other phenomena described above show how the various parts of the body machine depend upon a common supply of energy and how a usage of this common supply reduces the amount to be distributed.

During the period of work on the ergograph the operator experiences certain feelings or sensations which make it possible for him to realize the conditions of his acting muscles. At the outset of the experiment the load seems light and his muscles respond with little effort, but as the work continues a point is reached when he feels that the load is getting heavier and that his muscles are not responding to his efforts. Then soon he begins to feel a slight sense of pain upon contraction, which is a sensation transmitted from the tendons and muscles by way of the afferent fibers from the functioning parts. This condition is known as the sense of fatigue.

**Muscle Tonus.**—Muscle tonus is a condition of slight but continuous contraction of the muscle fibers as a result of a supply of a comparatively slight amount of nerve stimulus. It may be considered a condition of subdued tetanus and is just sufficient to keep the muscle fibers on slight tension. The stimulus of the efferent nerves which maintains muscle tone is in turn due to a slight stimulus sent into the cord and brain centers by way of the afferent nerves from the sensory surfaces. By this mechanism the motor centers are kept active, and reflexly the muscles are constantly receiving sufficient nerve stimulus to maintain their normal tension or tonus.

As evidence of this condition of muscular tonus it may be shown that the condition is lost in muscle to which the nerve supply has been sectioned, or by degeneration of nerve tissue or nerve centers from the effects of the various nervous diseases.

By sectioning the posterior roots it may be shown that these effects are controlled by reflex mechanism, as there is a corresponding loss of tonus to the muscles innervated from the segments to which the afferent supply has been sectioned. Since it has been shown that muscle tonus is due to the activity of both the afferent and efferent fibers it is equally true that muscle tonus is dependent upon the cell centers, their association fibers and the condition of the synapse, and, as will be pointed out later, the function of nerve centers depends upon conditions about and within the cord, such as blood supply, venous and arterial drainage, and normal movements of the vertebral segments upon which these factors depend. Osteopathically, then, the conditions determining muscular tonus are immediately apparent.

**Physiological Significance of Tonus.**—It is not difficult to see the value of a normal condition of muscular tonus to active muscle. The condition allows the ready response to stronger stimuli, thus rendering possible the regular and controllable and voluntary movements. The stimuli to the muscle also assist in some way in maintaining the normal nutrition of the muscle. It has not been demonstrated that the motor nerve has any specific trophic function to the muscles, but it certainly does in some way regulate the nutrition of the muscle. It may be that the maintenance of normal functional activity, which function is regulated by the nerve, determines the metabolic processes of the cells and in this way the motor nerve indirectly performs its trophic function.

The regulation of the temperature of the muscle and the skin surfaces depends upon this regular supply of nerve impulses to the structures. This temperature-regulating mechanism in turn determines the nature of the afferent impulses sent into the nerve centers, so it may readily be seen that the two functions are intimately dependent upon each other. The cutaneous trophism

determining the afferent stimuli to the nerve centers and the activity of the centers determine the efferent stimuli to the structures. The activity of the centers therefore would seem to be the most important of the three factors, and as long as the centers are functioning properly the adaptation of the other parts to environmental and other conditions may be expected to follow. It is known that the nerve centers may be affected by osteopathic lesions and the functional activities of such centers may be normalized by corrective manipulations.

## CHAPTER XXVIII.

### CHEMICAL PROPERTIES OF MUSCLE.

Muscle plasma, which constitutes nearly all of the cytoplasm within the sheath of the fiber, as shown by Kuhne is capable of undergoing coagulative changes when injury to the cell results.

This material clots and forms serum very similar to that formed in the process of blood coagulation. This clotting is thought to be the cause of the production of rigor.

There are two fairly well-known muscle proteins, myosin, a globulin, which in the process of clotting forms myosin fibrin; and myogen, an albumin, which in the process of clotting forms myogen fibrin, and these proteins are also thought to take part in the process of rigor.

Water constitutes about 75% of muscle. The quantity varies inversely with the age of the animal, young individuals having the greatest amount. It is also said to vary with different muscles of the same individual, but the variation is not great.

The water content is increased in tetanized muscle. Activity therefore seems to increase the water content.

Several other substances to be discussed more in detail later, such as sugar, glycogen, etc., are found in small amounts.

The following table, taken from Stewart, showing the composition of dead striated mammalian muscle, will serve to give the general composition. Variations from this may be found in different species and in different muscles even of the same individual:

Water .....	75 per cent	
Proteins .....	20 per cent	
Fats, lecithin, and cholesterin .....	2 per cent	
Nitrogenous metabolites { kreatin (0.2 to 0.4) xanthin } purin bodies	} 2 per cent	
Carbohydrates (glycogen, dextrose and maltose) .....		
Lactic acid .....		
Inosit .....		

Inorganic salts such as the carbohydrates, phosphates, chlorides and sulphates of sodium, potassium, calcium, magnesium, iron, and possibly some other metals are found in muscle, but the total quantity is less than one per cent.

**Muscular Rigor.**—Muscular rigor is a condition of muscle rigidity and contraction of muscle which is found to occur after death and is commonly known as rigor mortis. The changes known to occur are rigidity, shortening, an acid reaction results, there is a loss of irritability, and the proteins solidify, and the semi-fluid muscle plasma of the living state is reduced to a firm mass.

This condition passes away in from one to six days after death, and the muscles again become soft as before. In cold-blooded animals rigor occurs much more slowly. Another form of rigor, caused by quickly increasing the temperature of muscle, rigor caloris, may be considered as similar to, if not the same as, rigor mortis. It is supposed that the increase of temperature causes death of the tissues by effecting certain chemical changes and that the rigidity, etc., are due to the coagulative changes, the same as in rigor mortis.

### MUSCLE ENERGY AND WORK.

The source of energy for muscular contraction is the breaking down of the complex carbohydrate compounds and the reduction of such complex molecules to simpler molecules. By this process energy is liberated. This is the energy of muscular work. The exact nature of these chemical changes is not well understood, but they are for the most part oxidation processes liberating carbon dioxide and water, and are exothermic in nature. Heat energy is therefore produced.

It has been positively demonstrated that the source of energy does not come primarily from proteins, as was formerly believed, but that the stored glycogen in the muscle is responsible for the source of the stored or potential energy of muscle; that the reduction of glycogen means the liberation of such energy of muscle,



and that the amount of glycogen represents the amount which is available for muscular work.

It has been demonstrated that functioning muscle uses glycogen, but there is no appreciable loss of proteins during muscle activity. Contracting muscle can use fats to some extent as a source of muscle energy in the absence of glycogen.

**Chemical Changes of Active Muscle.**—It has been shown that there is an excess of carbon dioxide in expired air during muscular activity which has resulted from the chemical changes of the contracting muscles. The sugars undergo a process of splitting, resulting in the formation of lactic acid, etc., and oxygen is used up, but, as stated above, the exact chemical mechanism is not known. It is definitely known that in contracting muscle glycogen and oxygen are used and carbon dioxide and lactic acid are liberated. This means, of course, that the arterial supply must be good, that the muscle may receive oxygen and have its glycogen store replenished as it is used. It also means that the venous and lymphatic drainage must be active, that the carbon dioxide and lactic acid may be removed. If these products are not removed they inhibit further muscular activity.

**Muscle Energy.**—The reduction changes in glycogen and other chemical changes occurring in muscle are probably associated with the action of certain enzymes.

The reduction of the stored glycogen to sugar is effected by the action of an amylolytic enzyme, and the further reduction of the sugar is caused by the action of a glycogenic enzyme. This seems to be the best explanation of the causes of the energy producing chemical changes. Besides these there are other special enzymes, such as a proteolytic enzyme which has the power of digesting proteins, a lypolytic or fat-splitting enzyme, and coagulative enzymes which effect changes of coagulation in injured or dead muscle, causing rigor.

Glycogenetic changes are produced by muscle substances (enzymes) which convert the dextrose of the blood to glycogen, the latter being stored in resting muscle in quantities varying from

.5% to .9% of the muscle by weight. This glycogen, as stated above, is during muscular activity converted by the amyolytic enzymes to sugars.

During muscular contraction other less well-known chemical substances result. Phosphocarnic acid is produced, but the chemistry of the changes producing it are not known. Lactic acid is probably an intermediate product of the metabolic process. Nitrogen extractives, the nitrogen wastes, such as creatin, uric acid, etc., are formed, but their function, if any, in the contraction of muscle is not known.

**Energy Liberated in Muscular Activity.**—Energy, or the power to do work, is liberated in various forms during the oxidative changes which occur during muscular activity. Heat energy is liberated to some extent from friction, but this is very slight. The temperature of frog muscle is increased from .001° C. to .005° C. for each contraction. Mammalian muscle is often increased as much as one or two degrees as a result of contraction.

**Muscular Work.**—The term "work" in the physical sense refers to the result of a force applied through a distance and may be expressed thus:  $W = FX$ , in which  $W$  represents the work done,  $F$  the force applied and  $X$  the distance through which the force is applied.

The muscular mechanism is so adjusted that in proportion to other machines it does comparatively a greater amount of work in proportion to the energy used and the force applied. This is because of a more perfect adjustment of the working parts and the almost total lack of mechanical friction.

As compared with the different, well-adjusted engines which utilize from 15% to 30% of their applied energy in doing work, the muscle machine utilizes from 25% to 30%, or even more, of its available energy. About one third of the chemical energy liberated is actually used in doing work by the muscular mechanism. In some cases, as has been shown by men working at mountain climbing (Zuntz), from 35% to 40% of the heat energy produced by oxidative processes is utilized in doing work.

**Muscular Efficiency.**—The term efficiency may be defined thus

$$\frac{\text{Work done (measured in ergs)}}{\text{Force applied (measured in dynes)}}$$

It has been shown that the muscle machine has a comparatively high efficiency. This again is due to perfectness of adjustment and reduced friction. Muscular efficiency varies with different muscles and with the musculature of different individuals. Muscular efficiency may be much increased by proper and well-regulated exercises.

**Muscular Power.**—The term “power” is, in the physical sense, the time rate of doing work and may be expressed  $P = \frac{W}{T}$

or power equals the work done divided by the time of doing the work. There are certain general propositions which may be stated relative to the physical principles of muscular activities, and it seems advisable to express these in physical terms:

1. The distance through which contracting muscle may act varies inversely with the load lifted. This means that the muscle is capable of doing a certain amount of work with its available energy and no more, thus the application of the formula,  $W = FX$ . This may be shown by the use of a frog muscle in a muscle-nerve preparation. If the muscle be made to contract, lifting a known load, say 200 gms., it may lift that load through a certain distance, say two centimeters. If now the load be increased to 400 gms. and the stimulus again applied, the distance lifted is decreased and after a time the load may be increased to that point which the muscle will not lift. The term “absolute power” of muscle is that amount of load which the muscle will not quite lift.

2. In the physical sense no work is done by active muscle if the load is not lifted.

3. Chemical energy liberated in muscular contraction takes the form of heat energy, which is effective in increasing body temperature.

4. A certain optimum amount of load on a contracting muscle results in an optimum amount of work. If the muscle for any reason is overloaded it will not lift the load to so great a height.

and beyond the optimum the proportion is much reduced. (See above.) We may conclude from this that muscles have a certain limit of efficiency and that any strain beyond this limit markedly reduces the ability to do work.

**Muscular Tension.**—It has been shown that muscle is capable of resisting a comparatively great load without injury. Frog muscle can lift a weight of from 500 to 3,000 grams per cross sectional area of one square centimeter, and human muscle has a maximum tension of about twice this amount.

**Fatigue of Muscle Tissue.**—Some of the causes and conditions of muscular fatigue have been discussed. The chemical changes involved in fatigue are to be given here. The knowledge of some of the phenomena of fatigue will assist in an understanding of the chemical nature of the changes occurring:

1. If a muscle be allowed to rest after fatigued, recovery results. It would seem that this rest is needed for several purposes—to restore the used glycogen content, to repair tissue waste, and to allow time for drainage of the products of muscle metabolism.

2. If the blood supply is reduced to acting muscle it fatigues more quickly. If the blood supply is reduced after fatigue, the length of time of recovery is increased. If the blood supply is completely shut off from a fatigued muscle recovery does not occur.

These facts are easily understood, and simply mean that the muscle is capable of only a certain amount of work from its store of glycogen and other substances and that these must be supplied for functional restoration of a fatigued muscle.

3. If the venous drainage be interfered with, the same conditions as given under 2 will occur. This means that during contraction certain waste products are formed, and that these must be removed before functional activity of the fatigued muscle can be restored.

That these waste products inhibit contraction the following evidence may be offered: That extract of fatigued muscle when injected into the blood stream of a normal animal inhibits contraction in that animal. Control tests of this experiment have been

made by the injection of extracts of unfatigued muscle, which gave no result.

The fatigue, then, is due to two things: First, the deprivation of the muscle of its store of chemical supplies, and second, the collection of the products of muscle metabolism, e. g., lactic acid, carbon dioxide, acid potassium phosphate, etc.

The oxygen supply in addition to other substances furnished by the arterial blood is also necessary for the production of the oxidative changes, which occur during muscular activity.

### CAUSES OF MUSCULAR CONTRACTION.

The source of energy for muscular contraction is the stored glycogen and the ultimate cause is the reduction of the glycogen, or more especially the sugars resulting from the glycogen, but how the energy thus liberated is used in producing the shortening of muscle is certainly not well known.

As regards the direct cause of the shortening and thickening of the fibers which is known to occur in muscular contraction many theories have been advanced, some of which will be briefly given.

The theory advanced by Fick is that the contraction is directly due to increased chemical affinity. Weber held the idea that the contraction was due to an increased elasticity, caused by changes effected by the stimulation. Muller believed that the stimulus caused certain electrical changes in the muscle, causing attraction and repulsion. Changes in surface tension caused by the chemical changes occurring as a result of stimulation has been suggested. By this means it is supposed that the fibrils may be made to shorten.

At present the heat theory of Engelmann is receiving much attention. This theory assumes that the double refractive substance in contractile tissue plays an important part in that this substance absorbs the light bands of the singly refractive substances, thus causing the shortening of the fiber. Engelmann has further shown that non-living substances, such as catgut, when well soaked in water will shorten when heated and will

relax again when cooled. He explains this action by assuming that the heat produced in the muscle causes the absorption of water and that the absorption of the light bands may be similarly explained. The immediate cause of the shortening according to this theory is the inhibition of water or other substances as a result of the heating. By placing a piece of well-soaked catgut within the coils of a platinum wire or other conductor and passing an electric current through the coil it may be demonstrated that the gut will be caused to shorten as a result of the heat thus produced.

There seems to be another possible explanation of the effect of the heat produced by the chemical changes. It is known that a sphere is that form of a solid which contains the greatest possible content per surface area and it is further known that according to Charles's law the volume of a liquid or gas is correspondingly increased as the temperature is increased. Now, assuming that this law holds for the fluid content of the muscle cell, it would be reasonable to suppose that, if the temperature were increased the cell would necessarily shorten and thicken in an attempt to approach the form of a sphere, when its liquid content were heated. This seems reasonable as a supposition, but it is hardly probable that this factor alone could account for the amount of shortening when the temperature changes are so slight.



# SECTION VII

## NERVE TISSUE





## CHAPTER XXIX.

### STRUCTURE AND FUNCTION OF NERVE TISSUE.

**The Nerve.**—The term nerve is usually applied to a nerve trunk, which consists of hundreds or even thousands of separate nerve fibers. Each of these nerve fibers is an independent unit, destined to carry its own impulse to or from the cord or brain and in this way to regulate the functional activity of some special structure. The different nerve fibers are contained in supportive connective tissue known as endoneurium and the different fiber bundles are contained in other supportive tissue known as the neuroglia.

**Structure and Function of the Nerve Fiber.**—The nerve fiber consists of a central part, the axis cylinder, which is an elongated process of the protoplasm of the nerve cell. The axis cylinder contains many smaller threadlike fibers which are contained within an interfibrillar substance, the neuroplasm. It is generally considered that these neurofibrils are the true conductive media of the nerve fiber. The axis cylinder is surrounded by a covering known as the medullary or myelin sheath, known also as the sheath of Schwann. At regular intervals the myelin sheath dips in against the axis cylinder, causing the sheath to be segmented. These folds are known as the nodes of Ranvier. This causes the sheath to consist of nodes and internodes, each segment having its own nucleus which probably acts as its trophic center. The myelin sheath consists of fatty material, composed principally of lecithin, which is contained within the interstices of a firmer substance known as the neurokeratin. The medullary sheath is considered to have three general functions, as follows: 1. It is supposed to act as an insulator in that it prevents the leakage

of nerve impulse from the axis cylinder. As evidence of this it may be mentioned that those structures in which the most exact functioning is required, such for example as striated muscle tissue, are supplied by medullated nerve fibers, while other structures are often supplied by non-medullated fibers. It is also known that the main tracts of the cord do not become functional until the medullary sheaths of these fibers have been developed; 2. A second function of the medullary sheath is that of trophism. The medullary sheath probably furnishes nutrition to the axis cylinder and its contents, especially in the long nerve fibers. As evidence of this it may be mentioned that a thicker myelin sheath covers those nerve fibers which take the longer courses, since these structures could not be so well nourished from the cell body of which they are a part; 3. A third function of the myelin sheath is that of protection.

The medullary sheath is surrounded by another sheath, the neurilemma or primitive sheath. All of the above named structures developmentally are derived from the ectoderm with the possible exception of the neurilemma, which probably comes from the mesoderm.

The axis cylinder with its contents, the neurofibrils, is an outgrowth of protoplasm from the nerve cell, which serves as the nutritional and dynamic center to all the processes of the cell.

**Medullated and Non-Medullated Fibers.**—The medullated fibers are so called because they are covered by the medullary or myelin sheath. These fibers vary greatly in size. The larger medullated fibers are distributed to striated muscle and skin surfaces, while the smaller medullated fibers are distributed to the internal viscera. These visceral fibers are not distributed directly to the viscera by way of one continuous fiber process, but terminate in different collections of cells known as ganglia, some of which lie in the lateral chains and others in peripheral ganglia. From these ganglia other non-medullated fibers arise which carry the nerve impulses to the structure supplied. All nerve fibers belonging to the central nervous system, that is,

all of those which enter or leave the brain or spinal cord, are of the medullated type.

The non-medullated fibers differ from the medullated fibers in that they are not possessed of a medullated sheath, but have in most cases a primitive sheath or neurilemma. Ultimately these fibers break up into a network of many smaller fibers and the sheath which covers them is lost.

**Nerve Conduction.**—Just as muscle tissue is classed as contractile tissue, because its chief and only function is that of contractility, nerve tissue may be considered as conductive tissue, this being its only function. Conduction may be defined as the propagation of an impulse over a nerve fiber as the result of a reaction to stimulus. The nerve fiber with all of its parts constitutes a special structure for the performance of a special function. The neurofibrils of the axis cylinder may be considered as the true conductive medium, while other parts act as insulators and otherwise aid the axis cylinder in the performance of its function.

**The Nerve Impulse.**—Many theories have arisen relative to the nature of the nerve impulse. It was once believed that nerves consisted of tubes, whose function was to carry a kind of gas or spirit (animal spirit or nerve juice), which caused the functional changes in the structure supplied. This theory has, of course, been completely abandoned and other theories more scientific in nature have taken its place. The results of more recent research work on the subject have shown that the nerve impulse resembles to some extent the electrical charge as it passes over its conductor. The relations between the electrical current and the nerve impulse may be summarized as follows: The nerve impulse travels at a rate of about thirty-four meters per second (Helmholtz). Other research workers have estimated the rate of nerve impulse to be much greater than this. Piper estimates the rate of nerve impulse to be from 117 to 125 meters per second. In either case the rate of conductivity of nerve impulse is much greater than the rate of conductivity of the electrical current, which is less than 27 meters per second. The direction of conduction also varies, as the electrical current may be conducted

in either direction over its conductor, while the conductivity of nerve impulse is normally only in one direction. The direction of the conduction of nerve impulse by way of the axis cylinder of the axon is always away from the cell body, and may be said to be cellulifugal, while the conductivity of the dendrites is always towards the cell, or cellulipetal. A nerve trunk may be made to conduct in either or both directions if stimulated artificially in its mid-portion, but when normally stimulated by its cell body the impulse travels only in one direction.

**Variations in Conductivity.**—The conductivity of a nerve fiber may be influenced as to its rate and force of the impulse by many conditions, as follows: 1. Any increase in temperature increases the rate of conductivity in homeothermous animals up to a temperature of 50° C. Between normal temperature and that of 50° C. the rate of conductivity seems to vary directly with the temperature. Any decrease in temperature decreases the power of conduction and conductivity is lost at a temperature of 0° C.; 2. Compression of a nerve trunk retards or even destroys the power of conductivity and may do so without permanently injuring the nerve. This fact is of some osteopathic significance in that osteopathic lesions may in this way interfere with the normal conductivity of the nerve impulse and thus interfere with the functional activities of the structures supplied by the nerve involved; 3. Conductivity of nerve impulse varies directly with the oxygen supply to the nerve center and its processes. Since the oxygen supply to nerve as well as all other tissues is furnished by the arterial blood, we can readily see an application of Dr. Still's statement: "The rule of the artery is supreme." It is a well-known fact to osteopathic physicians from their clinical experience and has been repeatedly shown by the results of osteopathic research workers that an increase of the blood supply to nerve centers will cause an increased functional activity of the structures supplied by nerve fibers from these centers; 4. Anything which retards the venous or lymphatic drainage from a nerve cell or its processes retards the power of conduction by way of the nerve fibers. This condition follows as a result of the

effects of products of cell metabolism, which act as toxic substances to the cell when their removal is not properly effected. It should be remembered, as Sherrington explains, that "in the first place, nerve-cells, like all other cells, lead individual lives,—they breathe, they assimilate, they dispense their own stores of energy, they repair their own substantial waste; each is, in short, a living unit, with its nutrition more or less centered in itself. Here, then, problems of nutrition, regarding each nerve-cell and regarding the nervous system as a whole, arise comparable with those presented by all other living cells." We see from this understanding of the nerve cell that it is just as essential for the products of metabolism, such as carbon dioxide and other metabolic products, to be removed from the cell by a normally functioning lymph and venous drainage system as it is for these cells to be supplied by normal blood by way of the artery. It is well known, as has been shown by clinical and experimental evidence, that osteopathic lesions often retard the drainage of such products and in this way the lesion indirectly retards the rate of conductivity of the nerve impulse and decreases its power of functional activity; 5. Nerve conductivity is decreased or completely stopped by conditions of narcosis as a result of the administration of certain drugs, such as ether, chloroform, cocaine, chloral, phenol, alcohol, etc.; 6. Fatigue of a nerve fiber also reduces its power of conductivity, but conditions of fatigue of nerve tissue are not very thoroughly understood. Nerve tissue is commonly considered as being non-fatigable by continued functional activity, like other structures, but there are certain conditions which can hardly be explained other than by assuming that nerve tissue is to some extent fatigable. After one impulse has been discharged over a nerve fiber there is a period, although very short (.006 of a second after the first stimulation), during which time the nerve is inactive and will not conduct a second impulse. This is known as the refractory period. It has never been shown that there is any marked increase in the metabolic activities of the nerve during conductivity, and its temperature is only increased during conductivity .005° C. It is therefore argued by some that for

this reason the nerve does not fatigue during the passage of the impulse. There are certain conditions, however, in which nerve tissue is known to become non-functional from excessive activity (fatigue of the olfactory nerve, which diminishes or completely destroys for a time the sense of smell), and it is probable at least that all nerve tissue is fatigued to some extent from excessive activity.

## CHAPTER XXX.

### FUNCTIONAL DIFFERENCES IN NERVE FIBERS.

Since there are hundreds or thousands of separate and individual fibers in each nerve trunk and since so many different functional activities are to be initiated and regulated by these fibers, it would seem necessary for a wide degree of variation in the functional nature of the different fibers composing the different nerve trunks. This is found by experimental investigation to be true and that, while structural differences in the different nerve fibers constituting the nerve trunk may not be possible of demonstration, the functional specificity may be demonstrated. The reason for this specificity will be discussed later.

**Direction of Conduction.**—As has been explained, the dendrites of the neuron always conduct towards the cell body (cellulipetal conduction) and the axon always conducts from the cell to the peripheral structures supplied or to ganglia or dendrites of other cell bodies (cellulifugal conduction). The results of the notable work of Bell and Magendie first showed that the same nerve fiber can conduct only in one direction. Before this time physiologists had supposed that nerve fibers might be either motor or sensory.

**Afferent and Efferent Fibers.**—The terms motor and sensory, as applied to the direction of conduction in nerve fibers, is now known to be inaccurate, as not all outgoing fibers are destined to cause contraction in muscle tissue and not all incoming fibers are destined to cause sensation. As to the direction of conduction nerve fibers are more properly classified as efferent, referring to those neurons whose axones conduct impulses from some cell body in the brain, cord, or some ganglia to structures such as muscles, glands, etc., situated peripheral to its cell of origin.



Afferent neurons are those whose cell bodies lie for the most part near the cord or brain stem (in ganglia of the posterior root and ganglia of the cranial nerves), whose dendrites extend from some peripheral structure or ganglion to this cell body, and whose axon extends to some center or centers within the cord or brain. Afferent fibers normally receive their stimuli only at their peripheral endings and efferent fibers normally receive their stimuli only from their cells of origin. The difference in direction of conductivity, therefore, depends upon this structural difference of the neurones, namely, that the dendrites conduct towards their cells of origin, while the axons conduct away from their cells of origin.

**The Bell-Magendie Law.**—These workers, as mentioned above, discovered that nerve fibers conduct normally in only one direction and that all efferent (motor) fibers of the spinal nerves emerge from cell bodies located in the anterior gray matter of the spinal cord and pass out by way of the anterior roots. After passing through the intervertebral foramina these efferent fibers are distributed with the anterior and posterior divisions formed from this segment, and by these nerve trunks and their branches they are distributed to the various tissues supplied. These authors also showed that only afferent or ingoing fibers (sensory) were contained in the posterior roots. This law may be stated briefly as follows: The anterior roots of the spinal cord are strictly efferent and the posterior roots are strictly afferent in function. The principles of this law have many times been attacked, but no positive evidence has as yet been established against the law as stated.

**Afferent and Efferent Fibers Specific in Function.**—All afferent and efferent neurons may be further classified as regards the nature of their specific functions into excitatory and inhibitory fibers. By the term excitatory is meant that when these special fibers are stimulated the cells of the structures which they supply are excited to greater activity, and conversely when those fibers known as inhibitory fibers are stimulated the cells of the structures which they supply have their functional activity decreased and they are, therefore, properly called inhibitory fibers.

Excitatory and inhibitory fibers may be subdivided into many divisions according to their various specific functions. The following table of classification, as given by Howell, is quite explanatory:

Efferent..	{ Excitatory	{ Motor...	Motor	
			Vasomotor	
	{ Secretory	Salivary		
		Gastric		
{ Inhibitory	{ Inhibito-motor...	Subdivisions corresponding to the varieties of motor fibers above		
		{ Inhibito-secretory	Subdivisions corresponding to the varieties of secretory fibers above	
	{ Excitatory		{ Sensory..	Visual
		Auditory		
Afferent..	{ Reflex....	{	Olfactory	
			Gustatory	
	{ Inhibitory	{ Inhibito-reflex....	{	Pressure
				Temperature
			Pain	
			Hunger	
			Thirst, etc.	
			According to the efferent fibers affected	
			Inhibitory effects upon the conscious sensations are not demonstrated	
			The reflex fibers that cause unconscious reflexes are known to be inhibited in some cases at least	

The term "motor" is applied to those nerve fibers, efferent in function, which supply muscle tissue (somatic efferent), the striated muscle tissue being supplied by the efferent spinal nerves, whose cell bodies lie in the anterior horn of the spinal cord and whose fibers are distributed by way of the spinal nerves. Smooth muscle tissue is supplied by autonomic efferent fibers (visceral efferent), whose cell bodies lie in the antero-lateral part of the spinal cord and whose axones are distributed by way of the splanchnic

nic fibers to the tissues supplied. The vasomotor fibers, constrictors and dilators, are also autonomic efferents, which may be distributed either with the splanchnic fibers to the small arteries of the viscera or by way of the spinal nerves to the vessels within the structures which these nerves supply. The cardio-motor fibers are those which regulate the heart and are also autonomic. The inhibitory fibers are distributed to the heart by way of the vagus nerve and the accelerators by way of the spinal autonomies. These latter fibers are thought by some authorities to consist of two groups functionally: namely, the accelerators proper, which increase the rate of the heart beat, and the augmentors, which increase the force of contraction of the heart. The visceromotor fibers are distributed to the different organs by way of the cranial and spinal autonomies. They are divided into two groups, namely, the motors, stimulation of which increases the contraction of the smooth muscle of the viscera, and the inhibitors, stimulation of which decreases the contraction of the muscles of the viscera. The pilomotor fibers are those which supply the muscles of the hair follicles. These are also autonomic fibers. Secretory fibers are usually of two kinds, namely, those which are supplied to the glandular cells and seem to control the manufacture of zymogen granules or other substances produced by these cells and may be said to be trophic in function, while the other group of fibers (secretory proper) control the output of the secretions and determine the quantity of secretion produced. For specific examples of these the reader is referred to the mechanism of secretion of the salivary glands. Some authorities have also described inhibitory secretory fibers, the stimulation of which retards the functional activity of secretory glands. It may be that the functions of glandular tissues are regulated by many different types of nerve fibers, the functional nature of which is not at present understood. The nature of the specific actions of those fibers associated with the special sense organs will be found discussed under the physiology of those structures. Specific reflex fibers afferent in function are classified according to the nature of the change produced by efferent nerves stimulated by their reflex

effects. As an example of this we may mention the "pressor fibers," the stimulation of which affects the vaso-constrictor center or centers and thus reflexly causes an increase in systemic blood pressure. Those afferent fibers, the stimulation of which causes excessive activity of the vaso-dilator center or which in some other way causes reflexly systemic or local vaso-dilation, and therefore a decrease in blood pressure, are known as "depressor fibers." There are many other examples of specific reflex afferent fibers which cause definite physiological changes. It is highly probable that it is by the normal stimulation of the peripheral endings of these specific afferent reflex fibers that the various bodily functions are regulated in such a way that the functional activities of the organism as a whole are adjusted to its environment.

**Mechanism of Specificity of Nerve Energies.**—Since it has been shown that there is so much specificness of function in the various nerve fibers constituting the nerve trunks, it seems advisable to discuss the nature of the causes of this specificity.

There are several possible ways in which specific effects could be produced as follows:

1. The specificness of action might be due to some structural difference of the nerve fibers, but this does not seem probable, as no structural differences can be demonstrated histologically in certain nerves, which are known to have wholly different functions.

2. Specificness of function of nerve fibers might also be explained by assuming that there is a difference in the nature or force of the impulse, but "The usually accepted view is that they are identical in character in all fibers and vary only in intensity. According to this view, a sensory nerve—the auditory nerve, for instance—carries impulses similar in character to those passing along a motor nerve, and the reason that in one case we get a sensation of hearing and in the other a contraction of a muscle is found in the manner of ending of the nerve, one terminating in a special part of the cortex of the cerebrum, the other in a muscle." (Howell.)

3. It is probable that the nature of the end organ plays no small part in determining the nature of the impulse transmitted by way of the nerve. The end organ is in many cases of such a nature that it can be receptive to only certain kinds of stimuli. For example, it may be stated that the olfactory endings are susceptible to stimulation only by substances in the gaseous state, while the taste buds are sensitive to stimulation only by substances in the liquid state. The organs of Corti of the cochlea react only to vibratory stimuli. There are many different sensory endings (sensory receptors) of the skin surfaces which are specific, such for example as the well-known cold areas, warm areas, pain areas, pressure areas, etc. It may be seen, therefore, that the endings, or, we should say, the nature of the sensory receptors, have much to do with the determination of the stimuli received by their selective action. This mechanism explains only how certain kinds of stimuli or the stimuli produced by certain conditions are transmitted to specific nerve fibers. The stimuli received by these fibers is in turn transmitted to certain specific brain centers and it may be, in fact it is most probable, that the analytic and association function of these cortical centers have most to do with the ultimate determination of the nature of the stimulus received. The nerve fiber itself probably plays no important part in this kind of specific functioning. Stimulus by way of the optic nerve produces sensations of light. The normal stimulus to the optic nerve is light, which stimulates its end organ, the retina, but if the nerve be sectioned and artificial stimulus be applied to its central end a sensation of light will also result; so we see that the brain center, in some specific cases at least, is responsible for the function, which would seem to be due to the end organs.

4. The most probable explanation of the mechanism of specificity is that the receptive centers in the brain so analyze and associate their incoming impulses that the individual is enabled to determine the nature of the environmental or body conditions causative of the stimulus. It has been pointed out above how in seemingly very specific cases, where the end organs

are highly differentiated, such as the eye, the ultimate determination of the specificity is the brain center or centers. "On the identity theory of the nerve impulses the specific energies of the various nerves—that is, the fact that each gives only one kind of response—is referred entirely to the characteristics of the tissue in which the fibers end. If, as has been said, one could success, fully attach the optic nerve to the ear and the auditory nerve to the retina then we should see the thunder and hear the lightning." (Howell.)

It has also been shown that in the case of efferent fibers certain nerves the effect of which is to regulate the functional activity of glandular tissue, the result is due to the nature of the structure in which the efferent nerve terminates. If, for example, the nerve supplies to the parotid gland be switched, i. e., the cranial autonomic fibers (nerve of Jacobson) be cut and their peripheral ends attached to the central end of the cervical autonomic, and conversely the peripheral end of the cervical autonomic fibers be connected to the central end of the cranial autonomic and time be allowed for regeneration, stimulation of these nerves causes just the opposite effect when stimulated; i. e., the cranial autonomic fibers, instead of producing vaso-dilation and secretion as they normally should do, now produce vaso-constriction, and on the other hand stimulation of the spinal autonomic fibers (cervical sympathetics) is followed by vaso-dilation and secretion, which functions normally belong to the cranial autonomic fibers. (See nerve mechanism of secretion of saliva.)

## CHAPTER XXXI.

### PHYSIOLOGY OF THE NERVE CELL.

**The Neuron Doctrine.**—The main points of the neuron doctrine may be briefly stated as follows: 1. That the structural and functional units of the nervous system are the neurons has been established; 2. These neurons are not structurally connected, that is, there is no anatomical continuity of the fibers of different neurons, but there is a contact communication between different neurons; 3. That the processes of the nerve cell, the axon and dendrite or dendrites, are structurally and functionally parts of the cell and with the nerve cell constitute a complete functional unit, has also been established; 4. It is also known that nerve trunks consist of great numbers of these processes of nerve cells, both axones and dendrites; 5. The direction of conduction in the neurons is normally always towards the cell in the dendrites and away from the cell in the axones; 6. The impulse or "nerve current" is transmitted from one neuron to another by a contact (the synapse). Very little is known relative to the nature of this synaptic connection so far as the structural mechanism is concerned, but its functional nature is better understood, as will be shown later. The axon of one neuron connects or in some way is associated with another or others by terminating about the dendrites or cell bodies of the second neuron. By this arborization there seems to be an imperfect connection formed from one neuron to another, by means of which the impulses are transmitted.

**The Synapse.**—Many different views have been advanced relative to the structural nature of the synapse, but there is as yet very little known about it. Some of the different views are as follows:

1. The theory that the neurofibrils of one neuron are co-extensive with the same structures of other neurons is not generally accepted as an explanation of the histological nature of the synapse in the higher forms of animal life. It has been established, however, that such structures actually exist in some of the lower forms of life (the medusæ).

2. The theory of the existence of some kind of contact association between the axons of one cell and the dendrites of another seems to be a better explanation. The nature of this contact, however, is certainly not at the present time at all understood.

3. Other authorities believe a membranous division may exist, the resistance of which in some way influences the passage of the impulse from axon to dendrite or from axon to cell body. Concerning this view we quote from Sherrington as follows: "If the conductive element of the neuron be fluid, and if at the nexus between neuron and neuron there does not exist actual confluence of the conductive part of one cell with the conductive part of the other, e. g., if there is not actual continuity of physical phase between them, there must be a surface of separation. Even should a membrane visible to the microscope not appear, the mere fact of non-confluence of the one with the other implies the existence of a surface separation. Such a surface might restrain diffusion, bank up osmotic pressure, restrict the movement of ions, accumulate electric charges, support a double electric layer, alter in shape and surface-tension with changes in difference of potential, alter in difference of potential with changes in surface-tension or in shape, or intervene as a membrane between dilute solutions of electro-lytes of different concentration or colloidal suspensions with different sign of charge. It would be a mechanism where nervous conduction, especially if predominantly physical in nature, might have grafted upon its characters just such as those differentiating reflex-arc conduction from nerve-trunk conduction. For instance, change from reversibility of direction of conduction to irreversibility might be referable to the membrane possessing irreciprocal permeability."



The rate of nerve conductivity is probably the same in the tracts of the cord as in the nerve trunks, but there seems to be a marked delay in the speed of the impulses as they pass from the white to the gray matter, the so-called "latent period of reflex action." "The delay in the gray matter may conceivably be due to slower conduction in the minute, branched, and more diffuse conducting elements—perikarya, dendrites, arborizations, etc.—found there; or it may be referable to a fresh kind of transmission coming in there, a process of transmission different in nature to conduction along nerve-fibers. The neuron itself is visibly a continuum from end to end, but continuity, as said above, fails to be demonstrable where neuron meets neuron—at the synapse. There a different kind of transmission may occur. The delay in the gray matter may be referable, therefore, to the transmission at the synapse.

"And if the delay occur at the synapse, the possibility suggests itself that the time consumed in the latent period may be spent mainly in establishing active connection along the nervous-arc, which connection once established, the conduction in the arc then proceeds perhaps as speedily as does conduction in a simple nerve-trunk. The latent time would then be comparable with time spent in closing a key to complete an electric circuit or in setting points at a railway junction. The key once closed, the points once set, the transmission is as expeditious there as elsewhere." (Sherrington.) The osteopathic significance of the reflex arc will be discussed under another heading. (See index.)

**Relation of the Nerve Cell to Its Processes.**—As has been previously stated, the processes of the nerve cell—the axon and dendrites—are embryologically and anatomically parts of the cell, and taken together these parts constitute a functional unit. Separated from the cell, as a center, these processes are functionless. Developmentally the cell body is the structural and functional center of the neuron. The cell body appears first, then the processes develop by growing out from the cell. That the nerve cell is the nutritional center of the neuron was first shown by Waller, who demonstrated that, if a nerve trunk

is severed from its cells of origin, the peripheral part will degenerate. The time of degeneration occurs in from three to ten days after the section is made, the process being known as Wallerian degeneration. The degeneration always occurs in that part of the nerve process, axon or dendrite, peripheral to its cell of origin. That part which remains connected to the nerve cell does not degenerate except for a small part (two or three nodes of Ranvier), which may be due to direct injury occurring from the trauma of the sectioning. Although it is positively known that the cell is the nutritional or trophic center, it is not well understood how the cell body regulates this function over its processes. It may be that this nutritional function is effected by the activity of the axon which results from the dynamic force of the cell, which view would consider the degeneration as a result of disuse or inactivity. Another theory is that some kind of nutritive substance is actually carried from the cell to the processes.

**Practical Significance of Degeneration.**—This physiological fact is of value in tracing the courses of nerve fibers in the central nervous system. For example, if the anterior roots of one or two segments of the spinal cord be sectioned, the degeneration is always peripheral to the cells of origin, which lie in the anterior root of the cord. The degeneration, therefore, occurs in the efferent nerve trunks, which extend to and supply the muscles and other viscera. If the posterior root be sectioned, the direction of the degeneration depends upon whether the section is made central or peripheral to the ganglion on the posterior root. If the section is central to the ganglion, that is, between the ganglion and the spinal cord, the degeneration occurs in the tracts in the cord (the axons, which ascend brainward.) If the section be made peripheral to the cells of origin, that is, peripheral to the ganglion on the posterior root, the degeneration occurs in the incoming fibers, the dendrites, from the peripheral structures. If the spinal cord itself be sectioned or hemisected, or if degenerative changes occur from pathological lesions in the cord, the efferent fibers (fibers going from the brain to be distributed to the various cells of the cord) degenerate peripheral

to the point of lesion. On the other hand, the afferent fibers (axones extending from the ganglion on the posterior root or from cells in the cord) which are going brainward degenerate central to the lesion or between the lesion and the brain or upper cord termination. It will be seen, therefore, that the cells of the ganglion on the posterior root and the cells in the brain and cord, as well as the cells of the anterior horn (motor cells) act as trophic centers to their processes, the axones and dendrites. The same form of reaction of degeneration has been shown to hold good for the cranial nerves.

Since it is known that this process of degeneration occurs only in living neurons and since any severe injury to nerve cells or nerve trunks is constantly followed by such changes, the nature of the degeneration, that is, the functional disturbances, occurring in the structure supplied, such as paralysis, atrophy, etc., are usually safe guides to the source of the injury or pathological lesion causative of the condition. The length of time necessary for degeneration varies somewhat with different nerves and varies very greatly with different animals. In warm-blooded or homeothermous animals the degeneration often appears to begin within a few hours after the injury and is complete in the course of a few days, while in cold-blooded or poikilothermous animals the rate of degeneration is much slower, often requiring weeks or even months. In some instances in which the cause of the degeneration is some infectious or toxic agent affecting the nerve cell, the process may be slow and progressive, but even in these cases the loss of function in the structures supplied is often of sudden occurrence.

**Nerve Regeneration.**—Regeneration is a result of the process of development of new fibers from the old nerve cell in the path of the old (degenerated nerve trunk). Nerves do not grow back together after section. It makes no difference how soon the attachment of the nerve end be made after the section, there is never any "healing by first intention," as may occur in other structures. There is some difference of opinion as regards the nature of the regeneration. Howell states that "The regenera-

tion is due to the activity of the nuclei of the neurilemmal sheath. These nuclei begin to multiply and to form around them a layer of protoplasm, so that as the fragments of the old fiber disappear their place is taken by numerous nuclei and their surrounding cytoplasm. Eventually there is formed in this way a continuous strand of protoplasm with many nuclei, and the fiber thus produced, which has no resemblance in structure to a normal nerve fiber, is described by some authors as an 'embryonic fiber'; by others as a 'band fiber'."

After this first, "the initial stage," of regeneration has been completed the process ceases unless the peripheral end becomes attached to the central end of the old nerve, but this connection always results unless experimentally or accidentally prevented. The connection with the nerve cell by way of the central end of the old nerve trunk, "the band fibers", are quickly "transformed into a normal nerve fiber, with myelin sheath and axis cylinder." The axis cylinder is probably a result of extension outward of the original axis cylinder from the old nerve trunk, which has remained attached to the cell. The axis cylinder of the nerve stump probably finds its way into the newly formed nerve by a process of chemotropism (specific chemotaxis), as a result of the nerve tissue having a greater attraction for nerve tissue than for any other kind of tissue. There is little danger that the new, outgrowing, nerve will fail to connect with the peripheral end of the old, degenerating trunk because of this force which tends to bring them together.

**Classification of Neurons.**—The classification most commonly used considers the different types of neurons structurally under two general groups, as follows:

1. Bipolar cells. During the process of development the processes of these cells are so folded together that in the adult animal they may appear to arise from the cell as one common process, and the cell therefore appears to be unipolar. Soon after leaving the cell these two processes separate and take independent courses. One is the axon, the other the dendrite. The axon in the spinal nerves extends cordward and thence by way

of the ascending columns of the cord it extends brainward, while the dendrite extends to some sensory or other receptive surface. In case of the cranial nerves the axon extends brainward and the dendrite extends to some special or other receptive surface. The processes of these fibers develop medullary sheaths and the two processes with the cell body constitute an afferent neuron. Neurons of this type are found in the ganglia of the posterior root, in the spinal nerves and many cranial nerves. Developmentally these nerve cells originate from certain neural-crest cells, which have come primarily from the primitive folding of the ectoderm in the process of formation of the neural tube. These masses of neural-crest cells migrate ventrally (they are bilateral structures), and those cells which are destined to form the cells of the ganglion of the posterior root assume a position in close relation to the growing cord. Their axones grow into the cord. Some enter into synaptic relations with other cells and dendrites of other cells of the cord, while others extend upward or downward to form association connections and to form the long ascending columns. The dendrites of these cells during the process of development grow peripherally and constitute a part of the trunks of the spinal nerves. Since the dendrites always conduct towards the cell and since the axones always conduct away from the cell, it will be readily seen that these neurons could be only afferent in function. This hint on the development of these fibers explains why the fibers of the posterior horn are always afferent in function, and further explains a part of the law of Bell and Magendie. It seems well to add here that the rest of the cells of the neural-crest mass, that is, those which continue their migration ventrally, are destined to become the cells of the ganglia of the lateral chain and possibly of the peripheral spinal autonomic plexuses. It will be seen by more thorough study of the embryological development of the nervous system that all afferent nerves develop from cells lying outside of the central nerve axis, and because they must by this process of development grow into it they must also conduct towards the cord or brain, or both, and thus the explanation as to why they are afferent.

2. Multipolar cells. Two subdivisions of this type of nerve cell are known:

(a) Those neurons whose cell body is developed within the middle layer of the primitive spinal cord and which as the cord develops migrate to the anterior horn of the gray matter of the cord and become the cell bodies of the somatic efferents or motor neurons. Many other cells developed in a similar way from neuroblasts formed in the middle layer of the primitive cord and brain are the forerunners of other neurons of this type. Their dendrites are usually several in number and form receptive surfaces for many afferent fibers. These neurons are sometimes known as the Golgi first-type cells. The axones from these cells extend peripherally from the cell bodies in the gray matter. These neurons are of many different subdivisions according to their mode of distribution of their axones and dendrites. They constitute the anterior horn cells which give rise to the somatic efferent or motor neurons, the pyramidal cells of the cerebral cortex, and the Purkinje cells of the cerebellum.

(b) The other neurons, the Golgi second-type cells, are also developed from neuroblasts of the middle layer of the cord but do not migrate to any particular part of it, nor do their processes extend beyond the gray matter of the cord. These neurons differ structurally from subdivision (a) of this type in that their axones, instead of extending for long distances in the white matter of the cord as the spinal nerves, divide into many parts and are distributed in the gray matter only. Since these cells also have numerous branching dendrites and since none of the cell processes extend out of the gray matter, it would seem that the chief function of these neurons is that of association of the afferent and efferent systems. They serve to connect the afferent of one side with the efferent of the same side, and by way of the commissural neurons those which extend from the gray matter of one side to the gray matter of the opposite side serve to connect the afferent and efferent of opposite sides of the cord. These cells are fewer in number than sub-group (a) of this type, but are of very great value as association neurons, serving to associate the ter-

minations of the afferent neurons, of the bipolar cells with the efferent neurons described above. These neurons may be said to constitute the chief part of the synaptic nervous system.

**Source of Nerve Energy.**—It is generally considered that the nerve cell is the source of energy for the transmission of impulses and for determining the functions as well as the nutrition of its processes. The cell, then, may be considered as the dynamic as well as the trophic center of the neuron. The true source of this energy is the chemical changes which occur in the nerve cell, in the same way that chemical changes in other tissues furnish their source of energy. As evidence of the statement that nerve energy is due to its own metabolic changes we offer the following: 1. It is generally believed that nerve cells become fatigued after excessive activity, as other cells the energy of which is known to depend upon chemical changes occurring during their activity. It has been conclusively shown, for example, that the functional activity of muscle tissue depends upon the metabolic changes which occur within and about the muscle cells. The natural demand of sleep after mental work or emotional exercises seems to be necessary for recuperation, just as rest of muscle tissue is necessary for its recuperation; 2. If a quantity of blood be lost by hemorrhage or otherwise there is also this decreased nerve energy, which may be shown by the reduced power of mental activity as well as the decreased nerve force in the maintenance of normal tissue functions. This is an exact parallel of the conditions resulting in other tissues from the loss of blood, i. e., a loss of blood is always followed by a decrease in the power to function, and the loss of function varies directly with the loss of blood in nerve tissue as well as all other tissue; 3. It has been shown by experiments with the ergograph that the fatigue of the neuro-muscular apparatus also extends to the nerve cell and reduces its power to function; 4. The fact that mental and other work involving the nerve cell is almost impossible after excessive muscular exercise seems to bear out the above mentioned findings in the experiments with the ergograph, and further shows that the same fatigue which affects the neuro-muscular apparatus extends to and involves the higher centers of the brain and cord.

Mental energy, therefore, depends upon the same physiological conditions which determine other kinds of body energy, and while within reasonable limits all forms of body energy may be thought of as being constant, most certainly we cannot make the statement that nerve tissue is non-fatiguable while all other tissues are fatiguable.

Most tissues of the body (possibly all) are in a state of constant activity during life. This activity may vary greatly at different times according to the demands of function of different parts of the body and of the body as a whole. During sleep, for example, there is very little activity of the cells of striated muscle, but the cells of smooth muscle must maintain a certain amount of tone to continue their function, such as the demands of peristaltic action, and the required tone of smooth muscle of the arteries that proper blood pressure may be maintained, etc. All tissues are, therefore, capable of a certain amount of work without becoming fatigued, as their energy is constantly being restored. The continuous activities of the muscles of the heart and the muscles of respiration offer examples of this, but there is a limit to the amount of work which can be done by any tissue without fatigue, and we believe that nerve tissue offers no exception to this general law.

There is good experimental evidence to show (Mosso) that mental activity is followed by an increase of temperature of the brain tissue, just as an increase of temperature results from increased functional activity of other tissues. This, if true, would furnish evidence of what most physiologists believe to be a fact, namely, that mental work is the result of physical or chemical changes, or both, just the same as other body functions are explained. There is also other evidence of chemical changes in nerve tissue during activity and "Obvious histological changes which imply, of course, a change in chemical structure, have been observed by a number of investigators. All seem to agree that activity of the tissue, whether normal or induced by artificial stimulation, may cause visible changes in the appearance of the cell and its nucleus." (Howell.)



In addition to this evidence of changes occurring in nerve tissue during activity of the same we may refer to the fact, as stated in a previous chapter, that there is a brief interval of time after stimulation during which the nerve cannot be restimulated. This is known as the refractory period, and while it is very short (about .003 sec.), it still shows that the nerve cell is not capable of sending out stimuli continuously and without time for chemical changes to occur within its substance. Some, the somatic and visceral efferent nerve cells, are known to send out stimuli rhythmically, and we may assume that the rhythmical action of these cells depends upon the refractory period. The efferent cells of the brain cortex also seem to have the power of sending out impulses at somewhat regular intervals, but this may vary between certain limits, probably not less than thirty and not more than a hundred stimuli per second.

**Summation of Stimuli.**—It has been shown that if the nerve supply to a muscle be stimulated and quickly followed by a second stimulus, the application of the second stimulus produces a greater amount of contraction than the first. Furthermore, if a series of stimuli be applied to the muscle rapidly the contraction is markedly increased. This is explained by “the summation of the stimuli,” i. e., the second contraction occurring in addition to and before the effects of the first are lost. It does not seem probable that summation effects could occur in nerve tissue, as it does in muscle tissue, but it seems more probable that each impulse or unit of function is separate and independent.

## CHAPTER XXXII.

### NERVE REFLEXES.

**Definition.**—Nerve reflex may be defined as that involuntary response to afferent stimulation caused by efferent functional activity. The afferent stimulation causative of these functions may come into the cord or brain from many different sources and may consist of a great many stimuli functionally different in nature. Reflexes vary in nature because of the nature of the exciting stimulus, the kind of afferent fibers by way of which the impulse is carried, the strength of the exciting stimulus, the kind of centers involved in the cord or brain, and many other conditions, which are to be considered later.

**Reflex Mechanism.**—In every reflex act the involvement of the following structures occurs: 1. The sensory or receptive surface, from which the stimulus arises; 2. The afferent conductor (sensory nerve), which carries the stimulus to the centers in the cord or brain; 3. The synapse, the central connecting system by means of which the stimulus is transmitted to 4. The efferent conductor (motor nerve), which conveys the stimulus to the 5. Effector, such as a muscle, which is made to function as the result of the stimulus. Since nerve stimulus arises from without the cord or brain (there is little or no evidence to show that nerve stimulus arises spontaneously in the brain or cord), these five structural parts are necessary to all kinds of normal reflexes.

The sensory or receptive surfaces may be of many different kinds. The skin, which contains many functionally different receptive areas such as those which give rise to pain, pressure, temperature, and other sensations, constitutes one of the most important of the receptive areas. The mucous surfaces likewise

have the power of originating many stimuli, the effects of which are widely different in nature. Afferent endings capable of receiving and transmitting stimuli which are specific in nature are found in many other structures such as the muscles and joint surfaces, as well as the end organs of the special sense organs.

All afferent fibers serve the function of afferent conductors. The stimulus going into the cord or brain normally by way of these fibers serves to stimulate the cells of the gray matter sufficiently to maintain a normal "tone" in the structures supplied by the efferent neurons. As evidence of this it may be shown: 1. That the cutting of the posterior roots of certain segments of the cord reduces the tone of the muscles supplied by efferent fibers from these segments; 2. Stimulation of the central end of afferent or mixed nerve trunks increases the tone of the muscles supplied from the segments which give rise to the nerve trunk stimulated. There is also an increased functional activity of the structures of the abdominal and thoracic viscera, as a result of the reflex stimulation; 3. Section of the cord above a certain segment allows an increase in the reflex activities of structures supplied by nerves originating below the point of section. This increased reflex activity is due to the cutting off of the inhibitory functions of the descending neuron.

The synaptic connection within the cord or brain substance is also to be considered as an important part of the reflex mechanism, since the nature and function of this connecting mechanism determines the transmission of the afferent impulse to the efferent conductors. The reader is urged to read the physiology of the synapse and the experimental work given in Series No. 10. (See index.)

The efferent conductors are of two general kinds, viz., spinal and autonomic. These two groups may further be divided into many different subgroups according to the kind of structure supplied and the functions caused by their stimulation. (See classification of nerve fibers, Chapter XXXI.)

The fifth factor involved in reflex, the effector, is of course that which determines the function which is to result from the

reflex action. Effectors are of many different kinds, such as striated muscle, smooth muscle, secreting glands, etc. The effect of the reflex action on these structures may be either stimulatory, i. e., it may be of such a nature that the function of the structure is increased, or it may be inhibitory in action, reducing the function of the structures involved. In many of the coordinated reflexes both inhibitory and stimulatory effects may be noted on different structures involved in the reflex act. In case of the reflex, flexion of the arm for example, it becomes necessary to inhibit the tone of the extensor muscles while the flexor muscles are stimulated and made to contract.

**The Reflex Arc.**—Since all reflex actions result from the passage of a stimulus through certain nerve centers, a reflex arc must consist of at least two structures, i. e., an afferent conductor and an efferent conductor. In Fig. 24 this is shown by the afferent or sensory fiber entering the posterior root, its axon terminating about the dendrites of the anterior horn cell, whose axon extends to some peripheral structure. These two structures, the afferent and efferent elements, constitute the simplest form of a reflex arc. This explains the mechanism according to the neuron doctrine, and this mechanism answers in a simple way for the central association; but while this plan of transmission is known to actually exist in certain lower forms of animal life, it is doubtful if such simple association actually exists in the higher forms. The reflex mechanism of the higher forms is to be given later.

**Methods of Study.**—To study these reflex actions it is well to use some lower form of animal life like the frog. In order to determine the changes reflex in nature which affect the neuromuscular mechanism, the frog's brain is destroyed by cutting the head from the animal's body. It is advisable to pith the upper segments of the cord with a probe after the head has been removed. Such an animal is known as "a reflex frog." Frogs so operated may suffer from shock (see spinal shock), but this is only for a short time, after which the cord reflexes will react normally. Animals thus prepared serve the purpose of reflex study much better than those which have not had their brains removed,

because in the latter the reflexes are much more complex and therefore more difficult to study.

The fact that reflex activities can be shown to occur after the brain has been sectioned from the cord is evidence of the existence of reflex centers in the cord. That reflex centers exist in various parts of the brain may be shown in a similar way by exposing the brain and making sections beginning at the anterior portion and sectioning backwards until that part of the brain has been reached which controls a certain function. As soon as this point is reached the function in question will be destroyed. The reflex centers in the medulla, such as the respiratory center, the vasomotor center and others, may be located in the same way.

**Specificity of Reflex Action.**—Many afferent fibers are specific in their reflex function, i. e., they produce or increase the functions of only certain structures. An example of this has been given in the pressor and depressor fibers, which reflexly regulate blood pressure. (See Chapter VI.) Other specific afferent reflex fibers, such as those causing or regulating the secretion of the various glands, are known to exist, but the specificity of reflex function does not depend wholly upon the nature or kind of afferent fibers involved in the reflex act.

The nature of the results of reflex action are determined by different conditions, as follows: 1. The nature of the stimulating medium and the intensity of its application. Light, for example, is the only stimulus which can normally influence the function of the retina, and the intensity of the light determines the amount of reflex changes which result from the stimulus; 2. The nature of the receptive surface or end organ. Many receptive surfaces are susceptible to only certain kinds of stimuli, as in the example just given of the light on the retina, but this specificness in receptive function is not at all confined to the so-called special sense organs. Most viscera, for example, are not sensitive to handling or cutting, but their linings are highly sensitive to foreign substances. There would be little or no pain result from operating on the ureters or gall bladder, but the presence of renal calculi or gall stones is always causative of pain; 3. It has never been

definitely established that the nature of the impulse depends in any way upon the structure of the nerve fibers involved in the conduction, therefore it is not known that the specific nature of the reflex action is in any way dependent upon any structural difference in the afferent or efferent conductors; 4. The nature of the synapse, its location in the cord or brain, that is, the centers in the cord or brain involved, also play important parts in the determination of the nature of the reflex action. For the osteopathic consideration of the influence of conditions of the synaptic system on reflex activities, see Part II; 5. The end organ in

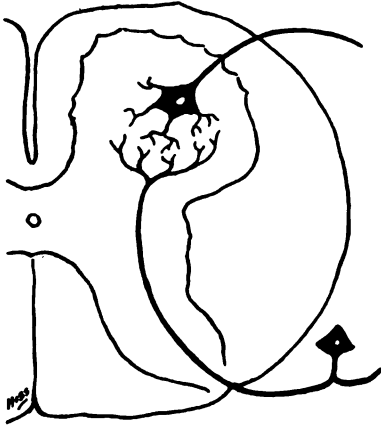

FIG. 24—This figure shows a simple reflex. The afferent or sensory fiber with its ganglion on the posterior root enters by way of the posterior root and its axon terminates about the dendrites of the cell of the anterior horn. Such a mechanism serves to illustrate the simple reflex but as stated elsewhere, probably does not exist in the higher forms of animals.

nearly all cases is that part of the reflex mechanism which has most to do with the determination of the nature of the reflex action.

**Kinds of Reflexes.**— 1. The simple reflex movements are effected by means of the simple reflex mechanism as shown in Fig. 24. As stated above, this mechanism is not common to the higher forms of animal life. "A simple reflex is probably a purely abstract conception, because all parts of the nervous system are connected together and no part of it is probably ever capable of reaction without affecting and being affected by various other parts, and it is a system certainly never absolutely at rest. But the simple reflex is a convenient, if not a probable, fiction. Reflexes are of various degrees of complexity, and it is helpful in analyzing complex reflexes to separate from them reflex components which we may consider apart and therefore treat as though they were simple reflexes." (Sherrington.) Reflex activities

resulting from simple reflex action affect only a single muscle. As an example of a simple reflex the movement of the eye in winking may be given, as this is usually only a contraction of the orbicularis palpebrarum.

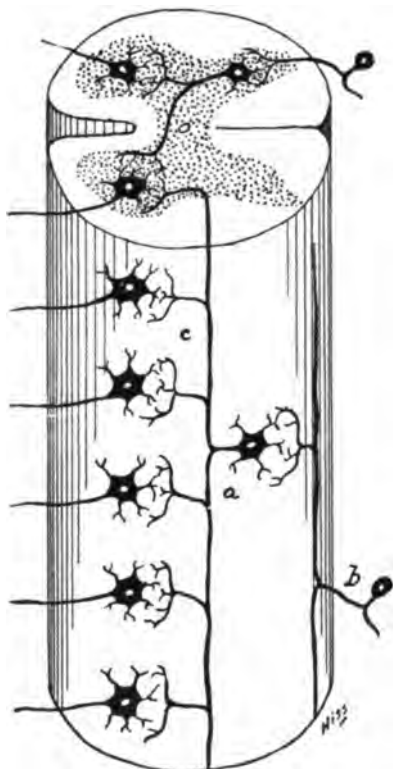

FIG. 25.—This figure shows the mechanism of a complex reflex arc. *b* is the afferent neuron entering the cord. *a* is the associating neuron in the cord. *c* represents the association of the intermediate neuron with the efferent neurones. (Taken from Brubaker, after Kolliker.)

2. The co-ordinated reflex actions differ from simple reflexes in that several muscles or groups of muscles are involved, the central connections are more complex (see Figs. 25 and 26), the functions of the muscles involved are so regulated and graduated that purposeful, useful, and orderly body movements result. These reflexes may be obtained in the reflex frog by applying stimulus to the skin surfaces. If the skin is removed or if it is in some way protected so that the stimulations cannot be uniformly applied, these results are not obtainable. Artificial methods of stimulation are never entirely satisfactory and the results obtained from such methods are often valueless and resemble the convulsive rather than the co-ordinated type of reflex action. "Adaptation has evolved a mechanism for

which one kind of stimulus is the appropriate, that is, the adequate stimulus: other stimuli than the adequate not being what the adaptation fitted the mechanism for, or at a disadvantage. Electrical stimuli are in most cases far the most

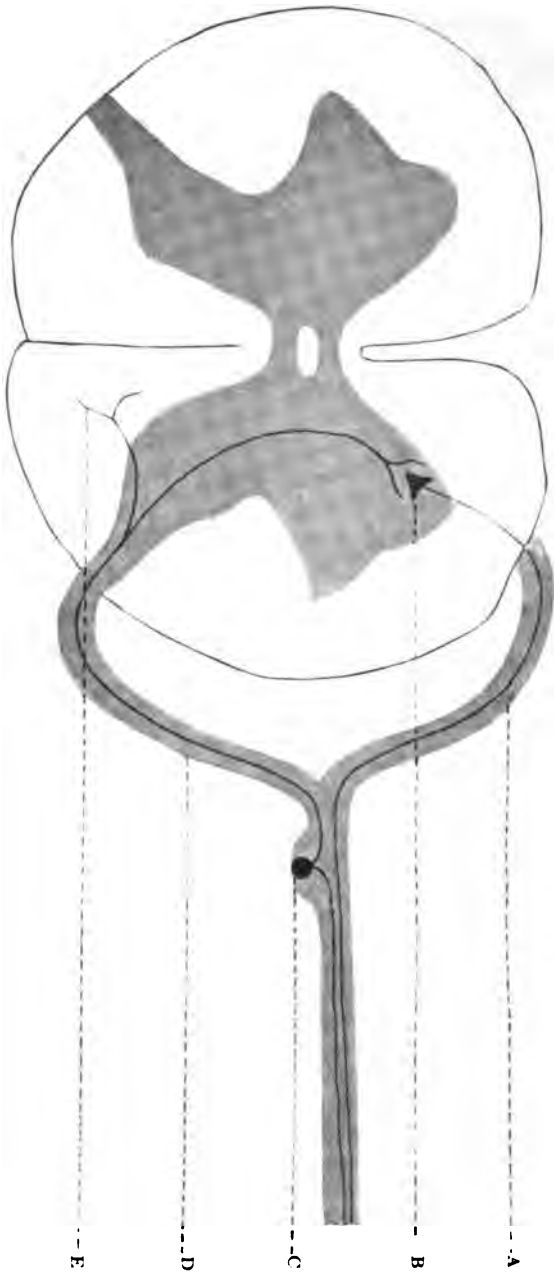

FIG. 26.—SIMPLE SOMATIC REFLEX ARC. (Courtesy of Dr. Burns.) A, anterior root; B, anterior horn; C, sensory cell; D, dividing axon.



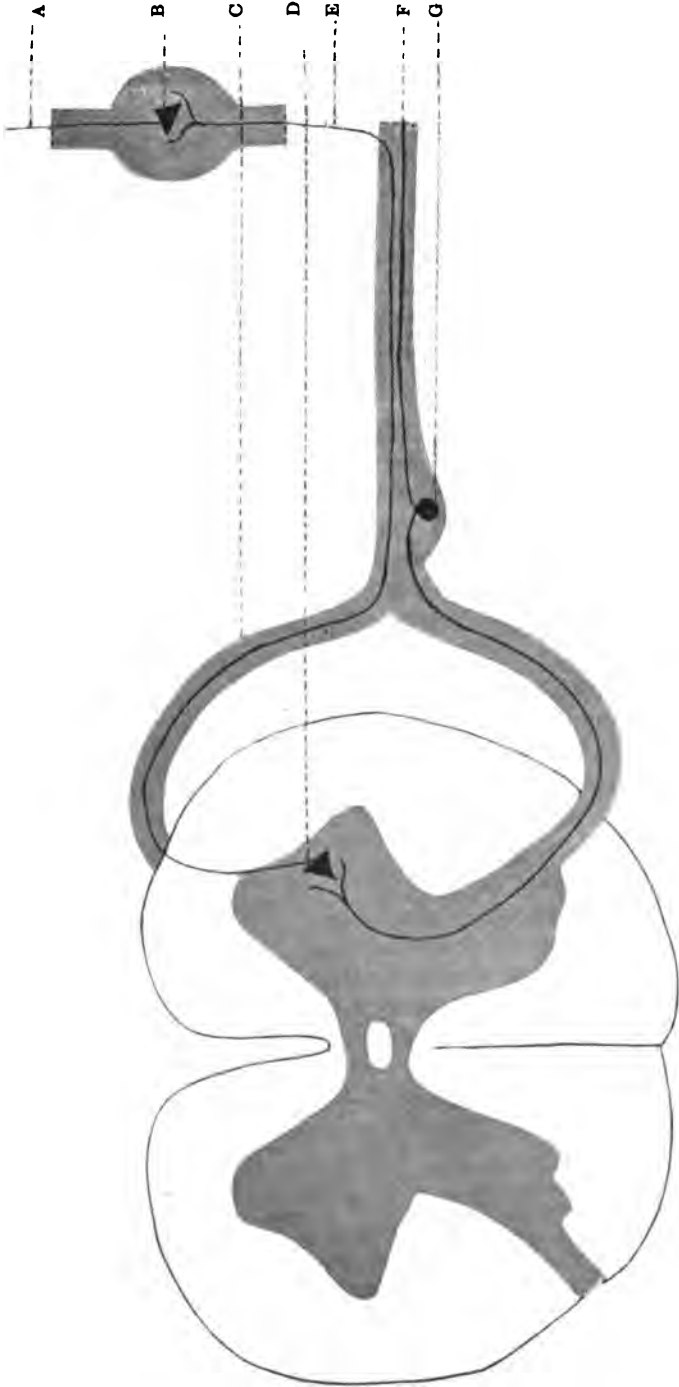

FIG. 27.—SIMPLE VISCERAL REFLEX ARC. (Courtesy of Dr. Burns.) A, Gray fiber; B, sympathetic cell; C, anterior root; D, lateral horn; E, white fiber; F, sensory; G, cell.

convenient to use for experimental work, because of their easy control, especially in regard to intensity and time. But electrical stimuli not being of common occurrence in nature, there has been no chance for adaptation to evolve in the organism receptors appropriate for such stimuli. Therefore we may say that electricity never constitutes the adequate stimulus, for any receptor, since it is always an artificial form of stimulus, and every adequate stimulus must obviously be a natural form of stimulation." (Sherrington.)

The fact that the skin surface is necessary for co-ordinated movements shows that the receptor surfaces of the afferent portion is a very essential part of the reflex mechanism. It has been shown that stimuli originating from the external surfaces cause reflex movements of the striated musculature and that stimuli originating from the interior, such as the mucous surfaces of the viscera, cause reflex movements of the smooth musculature. This, however, is not a constant rule, as external stimulation may in some instances affect internal reflexes.

By pinching the foot of a reflex frog the foot will be drawn away, or by applying a stimulus to the ventral surface the feet will be brought around in such a way as if to remove some foreign body, which would seem to show purposeful movements in both cases. The exactness of these purposeful reflex movements shows beyond question that the brain has little or nothing to do with the ordinary co-ordinated reflex movements. The centers in the cord, therefore, probably function in the unconscious reflexes. It may be that in the lower forms of animal life the spinal cord governs nearly all of the visceral as well as the striated muscular reflexes and that the brain, if such it may be called, is only a complex reflex center, which perhaps regulates some of the more complex reflex movements.

The co-ordinated reflexes are often so purposeful in nature when the brainless animal is carefully stimulated that it would seem that such movements are actually directed by intelligence. This is not the case. It is only the result of a highly developed automaton, purely mechanical in nature, which in answer to the

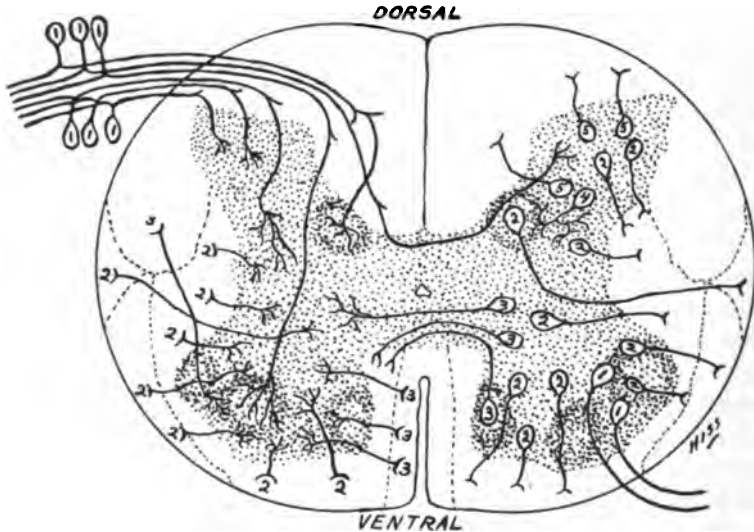

FIG. 28.—Showing afferent fibers entering the posterior horn of the cord, and the cell bodies and commissural fibers in the gray matter. The fibers entering the gray matter from the white matter are also shown. The right side shows the cell bodies and their distribution from the gray matter and the left side shows the entering fibers.

On the right side: 1. represents two motor fibers, one being the anterior horn cell whose axon is distributed to striated musculature (somatic efferent), and in the other the cell body lies in the antero-lateral part of the gray matter, its axon being distributed to smooth muscle (visceral efferent). 2. Cells of the gray matter, the axones of which pass to the white matter of the lateral columns. 3. Cell bodies whose axones pass to the opposite side by way of the posterior commissure. These neurones serve to connect the incoming fibers with the opposite side of the cord. 4. Golgi cells of the second type, whose short branching axones associate the different cells of the same side. 5. Cells whose axones pass to the white matter and help to form the posterior columns.

On the left side: 1. Fibers of the posterior root entering the gray matter of the cord. These fibers are, according to their distribution: (a) fibers which terminate in the posterior column (sone of Lissauer) of the gray matter and terminate about tract cells. (b) Fibers which terminate in the gray matter about tract cells whose axones go to the white matter of the same side. (c) Fibers which terminate in gray matter about cells whose axones go to opposite side (commissural). (d) Fibers which terminate about motor cells of the anterior horn, somatic and visceral efferents. These connections form the simple reflex, but it may be that intermediate fibers (Golgi cells of the second type) serve to make the connections. (e) Fibers which terminate about cells in the dorsal nucleus (Clark's column). (f) Fibers which terminate about cells whose axones go to the medulla. (g) Fibers which terminate about cells whose axones go to the opposite side by way of the posterior commissure. (h) Fibers which terminate about Golgi cells of the second type. (i) Fibers whose axones extend upwards in the posterior columns. 2. Fibers entering the gray matter from the lateral columns. 3. Fibers entering the gray matter from the descending pyramidal tracts and terminating about the efferent motor cells of the anterior horn. (Howell, after Lenhosseck.)

law of the demand of function has been developed for its own protection. It should be remembered that, phylogenetically speaking, the spinal cord greatly antedates the brain and that the cord's primitive function was that of regulating by reflex the various functional demands of the living organism. The brain and medulla may be considered in the more highly cephalized animals as highly differentiated and complex reflex centers and represent the maximum of nerve center development. Developmentally the brain has come from the cord and not the cord from the brain, as might be supposed.

3. Inco-ordinated, convulsive, or spasmodic reflexes differ from the above in that the muscles involved are thrown into spasmodic contraction with no order or regularity of movement. A single muscle, several muscles, or the entire musculature of the body may be involved. Spasmodic reflexes result from (a) an excessive sensory stimulation which causes a reflex response as a result of an "overflow of stimulus" affecting the neuro-muscular apparatus; (b) spasmodic reflexes may also result from an increased irritability of the nervous system as an effect of some toxic substance such as certain drugs, bacterial toxins, toxins of perverted metabolism, etc. This may be shown by injecting strychnia subcutaneously into a frog. After a few minutes the animal is much more susceptible to reflex stimulation and after a time the movements become convulsive. The cause of this hyper-irritability is most likely the accumulation of toxic substances about the cell bodies of the central nervous system, increasing their sensitiveness to stimuli. "The explanation usually given for this result is that strychnin, acting upon some part of the nerve cells, increases greatly their irritability, so that when a stimulus is sent into the central nervous system along any sensory path from the skin it apparently radiates throughout the cord and acts upon all the motor cells. This latter supposition leads to the interesting conclusion that all the various motor neurons of the cord must be in physiological connection, either direct or indirect, with all the neurons supplying the cutaneous surface." (Howell.) This is probably the explanation of con-

vulsions and other hyper-irritable nervous conditions which occur in certain infectious diseases, such as tetanus, hydrophobia, typhoid fever, etc. It is known that hyper-irritable conditions may result from osteopathic lesions, which we believe may be explained by assuming that these conditions are due to a summation of stimuli caused by the irritation produced by the lesion. The reader is referred to the chapter on the theories of the osteopathic lesion in Part II.

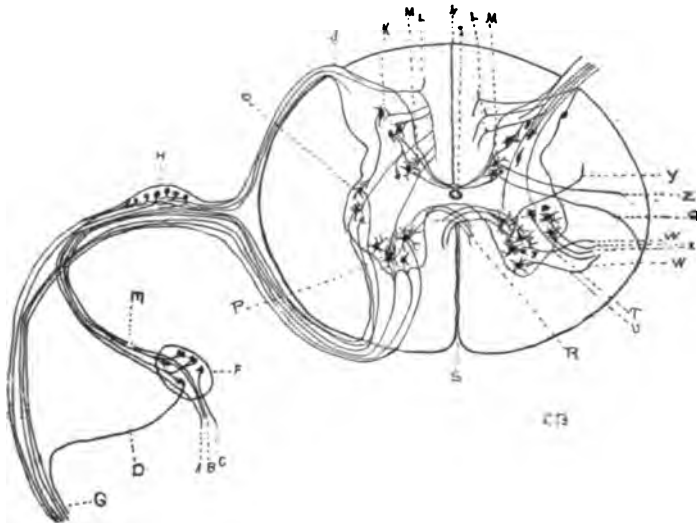

FIG. 29—(Courtesy of Dr. Burns.) "The fiber 'A' is viscerosensory. The body of the cell is in the sensory ganglion 'H'. The peripheral prolongation, properly called a dendrite, is medullated. It passes through the sympathetic ganglion 'F' without making any physiological connection with the sympathetic neurons. These fibers retain their medullary sheaths until they reach the neighborhood of their termination in the viscera. 'B' is a visceromotor fiber, the axon of a cell in the lateral horn 'O' of the spinal cord. These fibers form the greater part of the white rami communicantes, and they usually pass through one or more ganglia before forming a synapsis with sympathetic neurons. These fibers are medullated until they reach the ganglion of their termination. 'C' is a visceromotor fiber, the axon of a cell in the sympathetic ganglion 'F'. These fibers are not medullated, usually, and the medullary sheath is extremely thin in the very few instances where it is found at all. Impulses carried over these fibers are derived from the lateral horn.

"The lateral horn of the spinal cord 'O' should be considered as part of the autonomic nervous system, of which the sympathetic nerves also are a part. The nerve cells of the lateral horn of the cord are smaller than those of the anterior horn, and the axones of these cells are finer. The axones terminate by forming synapses with sympathetic neurons. The cells of the lateral horn of the cord receive impulses from several sources—from cells in the posterior horn 'K', from cells of the spinal ganglion 'H', by collaterals from their axons 'L', from the red nucleus by way of the rubro-spinal tract 'X', from the vasomotor and other centers of the medulla, and perhaps from other sources. Impulses are carried to the lateral horn only from sensory nerves and from centers which co-ordinate sensory impulses."

**Reflex Paths.**—In explanation of the co-ordinated reflexes it is generally assumed that the sensory impulses when they reach the cord or brain centers find a certain motor path of conduction to offer less resistance, and therefore pass out by way of this path. It may be further assumed that these pathways correspond to certain structural relations within the synaptic portion of the central nervous system, which explains why the impulses should follow certain paths and why certain reflex actions should result from certain kinds of stimulation and from stimuli reaching the central nervous system by way of certain nerve trunks. There is yet another factor, and that is the fact that these reflex pathways can be developed. By constant and continual usage of a certain set of muscles in answer to a certain need or afferent stimulation, such as the development of the use of the right hand in left-handed individuals which may after a time become the easier and more natural way and the individual may actually learn to use his muscles reflexly in this manner. The explanation of such a change seems to be the development of new paths of least resistance. Since these long continued practices often develop habit movements, the term "habit paths" has been given to those reflex transfer paths which, because after long practice they offer the path of least resistance to certain kinds of stimuli, which in turn results in the development of new reflexes.

The development of habit paths does not necessarily follow only the purposeful attempts to use another set of muscles than the ones structurally intended for the purpose, but may come as a result of continual usage of any set of muscles and is often if not nearly always unconscious after long and constant application. So much of our daily work, especially if one is doing work which is more or less of a routine nature, is a result of co-ordinated reflex movements that after careful observation of one's own actions, he will be forced to admit that a great number of his movements are purely reflex in nature and comparatively very few are volitional.

**Reflex Animals.**—The term reflex animal or spinal animal may be applied to any one of the higher animals like the cat,

dog, monkey, etc., which has had its brain sectioned from the spinal cord for the purpose of reflex study. Sherrington and others have successively shown that the brain may be sectioned from the cord and after time has been allowed for the animal to recover from the spinal shock it will show many interesting reflexes when the proper receptive surfaces are stimulated. When the skin of the ventral surfaces is stimulated the animal will bring its feet to the point of stimulation and perform movements as if it were voluntarily trying to scratch the surface stimulated. This is known as the "scratch reflex."

If the cord be carefully sectioned in the dorsal region the animal may be kept alive for months, and the stimulation of certain definite areas supplied by nerves originating from cord segments below the sectioned region will be followed by specific muscular movements; and in most cases the deep reflexes, such as the knee-jerk, also remain active. There is no degeneration of muscle or other tissue as the result of the section. It has been shown (Deason and Robb, and others) that complete section of the cord may be made in the cervical region below the origin of the phrenics and, if the operation be properly and carefully done, the animal may be kept alive for long periods of time and the reflexes obtained from segments of the cord below the section may remain active.

In the higher animals the reflex movements are neither so easily obtained nor so specific in co-ordination of purposeful movements as in the lower animals, such as the frog, because the higher animals are less dependent upon the cord and also because there is a much higher degree of development of the brain centers and the brain, therefore, has more to do with the regulation of reflex movements in the higher animals. In monkeys the reflexes in the apinal animal (after section of cord) are much less marked than in animals like the dog and cat. According to the degree of development the reflexes in the monkey after section of the cord are less marked than in the dog, and the reflexes in the latter are less marked than in the frog. In the human, as has been determined from clinical cases in which the cord has

been accidentally transected, the reflexes, both cutaneous and deep, are quickly lost and the musculature is said to lose its tone and degenerate.

It would seem from these facts that some general laws may be stated, as follows: 1. The independence of the cord in regulating reflex actions varies inversely with phylogenetic development; 2. The trophic influences exerted upon structures depend upon the perfect integrative functions of the cord to a greater extent in the higher forms of life than in the lower.

**Osteopathic Significance.**—From an osteopathic viewpoint these facts are of much significance. It is considered by some who have had little or no actual experience in the study of the osteopathic lesion experimentally that the first of these two principles (viz., that reflexes can be obtained in animals lower in the scale of development than man, but cannot be obtained in man) would tend to discredit the value of mammalian osteopathic research work, but these individuals are basing their claims wholly upon suppositions and entirely overlook the second of these two principles, viz., that minor lesions in animals might produce only very slight or possibly no discoverable change, whereas similar lesions in the anthropoid ape or the human would produce very marked functional disturbances as a result of the disturbance of the reflex integrity. As evidence of this we refer the reader to Series No. 12 in Part II, in which we have conclusively shown that artificial bony lesions in monkeys are followed by symptoms very marked in character and quite specific in relation to the region of the spine lesioned. We have further shown that marked trophic disturbances result from certain spinal lesions in monkeys, while similar lesions in dogs seem to produce no discoverable effects. This, then, if the law is to be continued, would show that the human is even more susceptible to the effects of minor spinal perversions, which involve the physiological integrity of the reflex mechanism of the cord and its nerve trunks. The reader is referred to the chapter on Reflex Action by Dr. Burns, to McConnell's research work, and to our Series Nos. 5, 9, 10, 11 and 12 in Part II.



**Inhibition of Reflex Action.**—By the term “reflex inhibition” is meant the depression or complete suppression of reflex action, which is caused by certain afferent impulses reaching the centers of the central nervous system. If a frog be decerebrated and the peripheral end of the exposed spinal cord be stimulated, the cord reflexes are markedly decreased or completely inhibited. In such cases stimulation of sensory surfaces fails to produce reflexes in the neuro-muscular apparatus of the animal. If the stimulus or stimulating substance be removed from the end of the cord the reflexes may again be obtained by the stimulation of sensory surfaces. It is stated elsewhere that one of the principal functions of the centers in the brain is that of exerting an inhibitory influence upon the reflex centers in the cord, which statement is sustained by the above experimental evidence. It may be that there are specific inhibitory fibers distributed from brain centers, the function of which is to afford a pathway by means of which certain reflexes, such as micturition, defecation, etc., may be voluntarily inhibited, but the positive proof of the existence of such fibers is lacking.

Another way in which spinal-cord reflexes are inhibited is by the application of strong stimulation to sensory surfaces. If, for example, pressure be applied to the upper or lower lip, it will often prevent sneezing. A similar inhibition of reflexes may be demonstrated by stimulating two or more areas of the skin surface at the same time, in which the case results are often not so marked as those occurring from the stimulation of a single area. It is supposed that the stimulation of a second area inhibits the reflex effects of the first.

**Reciprocal Inhibition.**—The usefulness of such an inhibition of reflex action has been shown by Sherrington in what he terms “reciprocal inhibition.” “In the end-effect of certain reflexes, for instance the scratch-reflex, there supervenes on a phase of excitatory state a state refractory to excitation—a refractory phase. This refractory phase is, if we seek to put it into the class of physiological phenomena to which it must obviously belong, a state of inhibition. In the scratch-reflex we

have therefore a reflex in which an external stimulus evokes as its end-effect an excitatory phase, succeeded by an inhibitory phase, and this succession in this reflex, the stimuli being continued, is repeated many times. If we denote excitation as an end-effect by the sign plus (+), and inhibition as end-effect by the sign minus (—), such a reflex as the scratch reflex can be termed a reflex of double-sign, for it develops excitatory end-effect and then inhibitory end-effect even during the duration of the exciting stimulus." (Sherrington.)

A sensory stimulus which excites motor impulses to a reflex muscle or to a group of reflex muscles inhibits the motor impulses to the corresponding extensor muscles, which makes possible the easy movement of the joints. The converse of the above rule is also true, viz., that when the extensors are stimulated the flexors are inhibited by the same reflex stimulus. This explanation probably serves to explain how in peristaltic movements of the intestine there is a wave of constriction preceded by a wave of dilation, the dilation being a result of reciprocal inhibition. Many other examples could be given of the physiological usefulness of reciprocal inhibition.

## CHAPTER XXXIII.

### RELATION OF THE SPINAL CORD TO REFLEX ACTIONS.

It must be remembered that the cord antedates the brain in its phylogenetic development and that in the lower forms of animal life (which have no brain) the cord serves as a reflex transfer and thus the nerve centers in the primitive spinal cord serve to reflexly adjust the animal to its environment. Since from the law of "the demand of function" there is a need for a more highly differentiated central nerve mechanism for the regulation of the more intricate functions made necessary by evolutionary changes, higher and more complex nerve centers are developed to meet this demand and thus in the higher forms we have animals with brains and complex brain centers.

In these higher brain centers, then, we find those nerve mechanisms which regulate the more recently acquired functions phylogenetically, e. g., the vasomotor centers for regulating blood pressure and velocity, the respiratory center for regulating the amount of oxygen according to the needs of the animal, the cardio-inhibitory center, the pupillary reflex center, etc., all of which structures function only in the homothermous or warm-blooded animals. In the poikilothermous or cold-blooded animals, in which there is no great need for an accurate regulation of body temperature, blood pressure, etc., these higher centers do not exist. Phylogenetically we may consider the brain as a physiological luxury and possessed only by those animals which enjoy the functions of much more highly differentiated structures, those which enable them to automatically adjust their bodily changes more accurately to their environment.

Thus we have seen that the function of the reflex centers of the cord and brain is that of enabling the animal to reflexly adjust its own body conditions to its environment. Life, according to Spencer, is "The continuous adjustment of internal relations to external relations," and it may readily be seen that there is a reason for a great structural complexity in the spinal cord of the higher forms of animal life.

### **PERVERTED CONDITIONS OF THE CORD WHICH INFLUENCE REFLEX ACTION.**

It has been shown in the previous chapter how the spinal cord of the higher forms of animal life is more easily influenced than in the lower forms, and this rule holds true for the higher forms of mammals, i. e., the reflexes of monkeys are much more easily affected by perverted structural and physiological conditions than in such animals as dogs and cats, and likewise the human cord is still more susceptible to such variations. The experimental evidence of this may be found in Series No. 12, Part II.

**Effects of Osteopathic Lesions.**—As evidence of the fact that osteopathic lesions influence spinal cord reflexes we may cite the reader to the results of the original experimental work of Drs. Burns and McConnell, given in Part II. Dr. Burns, in her chapter on Reflex Action, very clearly explains the mechanism of the physiological disturbances, and Dr. McConnell has determined the pathological conditions causative of these physiological perversions. The author, with Dr. Robb and other assistants, has further shown that osteopathic lesions materially affect the normal cord reflexes, and much work has been done to determine the nature of such disturbances. See Series Nos. 5, 7, 9, and 10, Part II.

Many different theories have been advanced to explain how bony lesions cause perverted physiological changes. These different theories will be found discussed in detail in Part II.

**Effects of Drugs.**—Certain drugs, such as potassium bromide, quinine, strychnin, etc., act like bacterial and other toxins upon

the cells and synapses in the cord, greatly altering the transmission of impulses, and the conduction through the synapse is greatly reduced. These facts have been observed clinically and confirmed experimentally.

### **NERVE TROPHISM.**

Nerve trophism may be defined as the nutritive regulating effect upon tissues which is exerted by the nerve supply. The facts that degeneration results in nerve tissue when sectioned from the cell body, that tissues degenerate when isolated from their nerve supply, and that many other perverted functional disturbances result from the different kinds of nerve disorders, is evidence of some kind of trophic influence exerted by nerve tissue upon the structures which they supply.

The following perverted physiological conditions have been known to result from nerve disorders: (1) Degeneration of muscle tissue, (2) decreased functional activity of glandular tissue; (3) decreased power of regulation of the vasomotors, (4) decreased activity of visceromotor and inhibitors, (5) decreased resistance to bacterial invasion, (6) restricted growth and degeneration of bone tissue, (7) degeneration of skin as a result of affections of both the afferent and efferent nerve supply, (8) abnormal functions of the sweat-secreting glands, and (9) decreased nutrition to the appendages of the skin, the nails, hair, etc.

**Trophic Properties of the Cord.**—There is conclusive clinical and experimental evidence to show that the normal reflexes occurring through the spinal cord are responsible for the normal tone of the tissues supplied by the efferent nerves. It is also known that this trophic function depends upon the complete integrity of the entire reflex mechanism. As evidence of this we quote the following from Starling: "After complete section of the afferent nerves from any part of the surface of the body there should be a tendency to trophic disturbances, such as the formation of ulcers, etc. Such ulceration is frequently observed in patients suffering from spinal disease. After section of the

first division of the fifth nerve ulceration of the cornea is often produced. These effects are, however, merely due to the absence of the normal protective reactions of the part, and can be prevented by scrupulous cleanliness and protection of the apæsthetic part from all possible injuries. There are other trophic effects caused by nerve lesions which can not be ascribed to the mere absence of protective reflexes. Thus inflammation of the posterior root ganglia often sets up herpes zoster, or 'shingles,' in the region of cutaneous distribution of the corresponding sensory nerve. Changes in the skin ('glossy skin'), nails, and hair are often seen after irritative injuries of nerves to the part."

It has been stated elsewhere that section of a nerve trunk supplying a certain structure decreases the functional activity of that structure and reduces its resistance to infection. Some degeneration occurs if the afferent fibers or the receptive surfaces are affected as stated above, but the greatest changes occur from section of the efferent nerve. It is known also that the synaptic part of the cord must function properly in order that the normal trophic influences exerted by the efferent fibers may result.

**Trophic Nerves.**—It is not known how the nerve supply from the cord or brain maintains the normal trophic functions of the structures supplied, but that it does effect such an influence has been positively demonstrated. It is held by many authorities that there are no specific trophic nerve fibers, but that the loss of tone in tissues to which the nerve supply has been sectioned is due to the decreased activity of the structures. In many instances this is probably true, but even in these cases the nerve is the ultimate cause of the activity and the normal integrity of the entire reflex mechanism is responsible for normal structural nutrition.

In a few cases at least, specific metabolic nerve fibers have been demonstrated. The nerve supply to the salivary glands offers an example of this. The spinal autonomic fibers are specifically trophic in function; i. e., the stimulation of these fibers has been shown to cause the formation of zymogen granules, and the cranial autonomic fibers have been demonstrated to control

the amount of secretion. Similar functions have been demonstrated to result in many other glandular tissues.

As evidence against the value of trophic nerves Starling suggests that "it is only during post foetal life that the activity of the skeletal muscles is determined by the motor nerves of the cord. Thus they may be developed normally even in the complete absence of a central nervous system. Whether we are justified in assuming the existence of trophic nerves exercising an influence on the nutrition of the part they supply, apart from any influence on its other functions, the experimental evidence before us is not sufficient to decide;" but this theory does not consider the facts that in the young nutrition and growth are influenced by the secretions of certain ductless glands, such as the thymus gland, which soon atrophies, and, were it not for some other mechanism assuming these functions we might expect a failure in nutrition just as that which does occur when nervous disorders develop, or we might better say when the nervous system fails to develop and function normally.

**Trophic Nerve Paths.**—As stated above, trophic nerves have not been demonstrated except in a few instances, but there is good reason to believe that the muscles receive their trophic influence by way of the motor nerve fibers and that the viscera receive their trophic innervation from the efferent autonomies. It does not seem necessary that fibers specifically trophic in function need be demonstrated to show that such influences are caused by these nerves. It is known that many of the visceral efferent fibers regulate these specific functions of the structures they supply and this function being lacking because of some failure on the part of the nerve would mean a perversion of metabolism and this, when we consider the entire body as a unit instead of a mass of segregated structures, would mean bodily disturbance as the result of functional failure on the part of some organ or organs. Let us urge again that the student bear in mind that every organ in the body bears a certain functional relationship with every other organ, and that the nutrition of the body depends upon the nutrition of its individual cells. (Starr.)

**Source of Nerve Energy.**—That the nerve energy comes from the metabolic changes occurring in the cell has been pointed out in previous chapters. It may be considered as automatic and originating within the cord as a result of the food supply furnished to the cells by the circulating body fluid. As evidence of this we have the following: 1. Section of the cord above does not destroy the trophic properties of the cord cells; 2. Section of the posterior roots or degeneration of the posterior columns is not in itself always causative of trophic disturbances; 3. Any decrease in the normal blood or lymph supply to the cord decreases the functional activity of the cells in the cord. The fact that the presence of oxygen is necessary for normal nerve conductivity and that the presence of  $\text{CO}_2$  decreases conductivity has been repeatedly demonstrated by laboratory tests. 4. Anything which prevents the normal drainage of venous blood or lymph from the cord, thus failing to relieve the cells of their products of metabolism (wastes), reduces the functional activity of the nerve cells in the cord.

As further evidence that an increased blood supply and venous drainage increase the functional activity of the nerve cells in the cord, the results of Series Nos. 16 and 17 show that an increased functional activity of the structures supplied by certain nerves results from osteopathic treatment (not massage) when applied to the segments of the spine from which the nerve supply originates.

It is known that certain chemical changes take place in nerve cells when they function, just as occur in other cells of the body. It is also known that there is a slight increase in temperature due to these metabolic changes. It has been demonstrated that during this metabolic process, which is believed to be responsible for the production of energy for the transmission of the impulse, oxygen is used and  $\text{CO}_2$  and other end products are set free. If, now, these end products are not removed they act as toxic agents to the nerve cells, and at first probably excessively stimulate as other toxins do and finally inhibit the function of the nerve cells.



It is known that the afferent nerve supply assists in maintaining the functional activity of the nerve cells in the cord, and therefore a perfect integrity of the afferent and synaptic systems is necessary for normal functional activity of the nerve cells in the cord.

**The Osteopathic Significance** can readily be seen. Since the functional activity of these cells which determine trophic influences depends upon the general nutrition of the cord, and since the normal nutrition of the cord depends upon its blood supply and venous and lymphatic drainage and the integrity of its afferent and synaptic systems, it is only natural to inquire upon what these conditions depend. Proper adjustment, normal movement and normal functions of other structures which influence these segments of the cord reflexly, is the answer.

**Cord Functions Automatic or Reflex?**—Two general views are held relative to the way in which the spinal cord regulates the functions of the structures supplied by its nerves. One theory is that its nerve force is due to automatic physiological action and the other is that the energy of the nerve cells of the cord is a result of reflex excitation. As evidence of the first view, viz., that nerve force originated “spontaneously” in the cord, the facts given in the preceding paragraphs may be restated. In addition to this it should be mentioned that section of the cord above or sectioning of the afferent nerve roots does not completely destroy the action of the efferent fibers.

As evidence of the second theory we have the following: 1. Muscular movements are all increased by sensory stimulation, such as direct nerve stimulation or the sudden application of heat or cold to receptive surfaces; 2. Toxins of bacteria or as a result of perverted metabolism, which excite the cord centers to greater activity, increase muscular tone; 3. Secretion may be influenced reflexly; 4. Drugs which reduce the activity of the sensory endings reduce consciousness; 5. Mental activities are reduced by anything which reduces the activity of the sensory nervous system or which interferes with the integrity of the reflexes. Anything which reduces the sensitiveness of the central nervous system

reduces the power of the mental faculties; 6. The fact that nowhere in the nervous system is it possible to find an entirely isolated neuron would seem to be evidence of the theory that all nerve functions are a result of reflex action.

We may conclude from the above theories and the evidence of each that nerve energy is dependent upon, first, the blood supply and venous drainage to the nerve cells, which factor is absolutely necessary to normal function; and, second, that the excitation of these cells to activity depends upon their perfect structural and functional relations with the afferent system and the synaptic system, which effects the physiological connection of the cells in the cord with the afferent system.

**Muscle Tone and Its Relation to the Cord.**—Muscle tone depends upon the motor nerve supply, as is evidenced by the atrophy resulting from the sectioning of the anterior roots, etc. Muscle tone also depends upon the afferent nerves and their sensory endings and the perfect integrity of all structures involved in the complex reflex arc. In the lower animals, and to some extent in the higher animals, muscle tone is independent of the brain centers. Anything, then, which interferes with the afferent and efferent paths or the synaptic nervous system reduces muscle tone.

**Effects of Extirpation of the Cord.**—It has already been seen that the spinal cord exercises a tonic activity by way of its nerve trunks upon the various structures of the body and that in addition to this the cord centers reflexly perform an essential function in the co-ordination of the functions of the different structures by virtue of their reflex associations.

Various research workers have studied the effects of hemisection and complete transection of the cord in various regions, but the complete removal of the cord was first successfully practiced by Goltz. The cord was first transected in the upper thoracic region and the peripheral portion entirely removed by very careful surgical operation. The results were as follows: 1. There was a loss of muscular tone and atrophy of all striated muscle supplied by nerves originating from the segments removed; 2.

There was also loss of sensation in these same structures; 3. There was at first a loss of the tone of the muscles of the blood vessels, but this tone seemed to gradually return; 4. The functions of the viscera were materially affected and the vessels of the viscera were also affected even in those cases in which the lateral chain ganglia, the splanchnic nerves, and the vagi were left intact. This fact would conclusively show that, while the autonomic system is to some extent independent of the central system, the co-ordinative and trophic function of the autonomic fibers depend upon the reflex and trophic influences of the cord; 5. The power to preserve normal temperature was decreased. As stated elsewhere, the thermogenic centers are probably located at a higher level in the central nervous system, but the results of this experiment would show that there are probably other secondary centers which control temperature regulation located in the various levels of the cord; 6. Susceptibility to inflammation and infection was increased in the splanchnic areas. This fact offers further evidence of the trophic influences of these nerves; 7. There was reduced power of adaptation to both internal and external changes, which fact offers further evidence of the co-ordinative influences exerted upon the different structures by the spinal cord; 8. There was reduced power of co-ordination, which is claimed by some authorities to be in part due to the irregularity of the blood supply to the different structures.

**The Spinal Centers.**—The reader is referred to the chapter on this subject written by Dr. Burns, which is to be found in Part II. The results of our research agree so thoroughly with her conclusions that we have nothing to add except to substantiate her findings.

**The Knee-Jerk.**—This term is given to that phenomenon which is characterized by the sharp, short forward kick which follows the tapping of the patellar ligament below the knee. The kick is caused by the quick contraction of the quadriceps femoris and is supposed to be the result of a reflex stimulus to the fibers of these muscles. The reaction is best obtained when the patient sits with the legs hanging freely or has one knee crossed over the

other. Since the knee-jerk may be obtained in normal individuals, it is of much diagnostic value in determining conditions of the cord. Any condition which interferes with any part of the reflex arc, retarding the transmission of impulses through the arc, decreases the knee-jerk. Any affection, therefore, which reduces the normal functions of the spino-muscular lower motor neurones or decreases the sensitiveness of the synaptic associations in the cord reduces or destroys the knee-jerk if the affection involves those segments of the cord from which the nerves arise which supply the lower limbs. On the other hand, any affection which reduces the functions of the cortico-spinal (upper motor) neurones and therefore reduces the inhibitory influences, thus allowing the cord reflexes to act excessively, increases the knee-jerk.

The knee-jerk may be augmented if the patient uses some of his other voluntary muscles, as in gripping something with his hands at the same time the tendon is tapped. Some authors have questioned whether this phenomenon is actually a reflex, but the weight of evidence seems to be in favor of the view that it is.

There are many other diagnostic reflexes which may be found fully described in the various works on diagnosis of nervous disease.

## CHAPTER XXXIV.

### CONDUCTION PATHS OF THE CORD.

The nerve structures in the cord consist of different series of columns of cells and fiber paths and the association and commissural fibers. The student is urged to refer to texts on anatomy for the structural arrangements of the fiber paths and cell columns. The most important columns of the cord are given in the following outline:

#### I. Ascending or afferent columns.

##### 1<sup>1</sup> Posterior columns:

##### 1<sup>2</sup> Column of Goll, posterior mesial fasciculus, fasciculus gracilis.

1<sup>3</sup> Origin, lower sacral segments.

2<sup>3</sup> Termination, gracile nucleus.

1<sup>4</sup> By way of lemniscus to end in,

2<sup>4</sup> Area of body senses.

3<sup>3</sup> Location in cord, see anatomy.

4<sup>3</sup> Functions:

1<sup>4</sup> Muscle sense, chiefly from voluntary muscles, tendons, and joints.

2<sup>4</sup> Co-ordination.

3<sup>4</sup> Touch (probably pressure sensations, but no pain nor temperature).

##### 2<sup>2</sup> Column of Burdach, postero-lateral fasciculus, fasciculus cuneatus.

1<sup>3</sup> Origin, mid-dorsal from posterior root ganglia.

2<sup>3</sup> Termination, nucleus cuneatus.

3<sup>3</sup> Location in cord, see anatomy

4<sup>3</sup> Functions:

1<sup>4</sup> Same as Column of Goll.

2<sup>1</sup> Lateral columns:

1<sup>2</sup> Column of Flechsig, fasciculus cerebello-spinalis, direct cerebellar tract.

1<sup>3</sup> Origin, upper lumbar region.

2<sup>3</sup> Termination: Most fibers enter the restiform body (inferior peduncle) of the cerebellum on the same side and terminate in the vermiform body of both sides. Some fibers terminate in the gray matter of the upper part of the cord.

3<sup>3</sup> This column consists of fibers from Clark's column.

4<sup>3</sup> Location, see anatomy.

5<sup>3</sup> Functions:

Muscle sense, muscle tone, co-ordination; some fibers are commissural.

2<sup>2</sup> Column of Gowers, superficial antero-lateral fasciculus.

1<sup>3</sup> Origin, upper lumbar region, cells of the posterior horn of the same and opposite sides.

2<sup>3</sup> Termination: Some fibers terminate in the cord. Most fibers pass to both sides of the vermiform body by way of the superior peduncle and valve of Vieussens. Most of the terminal fibers pass to the same side; a few pass to the opposite side to the superior corpora quadrigeminal body and the optic thalamus.

3<sup>3</sup> Location, see anatomy.

4<sup>3</sup> Functions:

Muscle and joint sense, muscle tone, co-ordination, pain, temperature; some fibers are commissural.

## II. Descending or efferent columns.

1<sup>1</sup> Pyramidal tracts.

1<sup>2</sup> Crossed pyramidal, lateral descending columns:

1<sup>3</sup> Origin, pre-Rolandic area of the cerebral cortex.

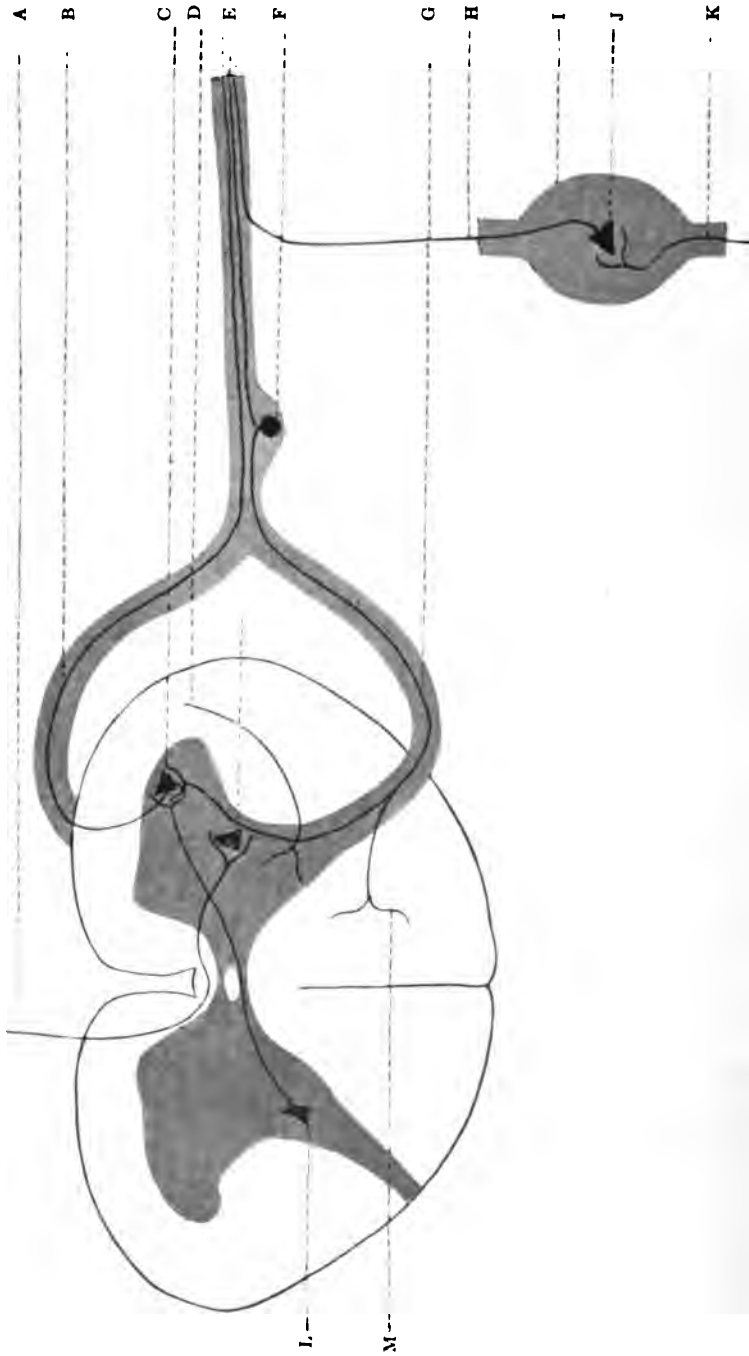

Fig. 30.—CONTROL OF THE BRACHIAL MUSCLES. (Courtesy of Dr. Burns.) A, Direct pyramidal; B, anterior root; C, anterior horn; D, rubro-spinal; E, mixed nerve; F, sensory; G, posterior root; H, gray fiber; I, sympathetic chain ganglion; J, cell; K, white fiber; L, commissural fiber; M, branch of afferent fiber.

2<sup>3</sup> Termination, gray matter of the anterior horn and Clark's column to the fourth sacral segment.

3<sup>3</sup> Location, see anatomy.

4<sup>3</sup> Function:

Voluntary muscular control. These descending axones terminate about cell bodies of the anterior horn of the gray matter of the cord and function as inhibitors to reflex movements, as has been explained in previous chapters.

2<sup>2</sup> Direct pyramidal, anterior descending column:

1<sup>3</sup> Origin, Rolandic area of the cerebral cortex.

2<sup>3</sup> Termination, mid and lower dorsal regions of the gray matter of the anterior horn of the opposite side.

3<sup>3</sup> Location, see anatomy.

4<sup>3</sup> Function:

These axones regulate the functional activities of the cell bodies of the spino-muscular neurones which are located in the gray matter of the anterior horn. Their function is chiefly that of inhibition, as stated above.

2<sup>1</sup> Cerebro-cranial tracts.

These fibers originate from centers in the brain and medulla and pass peripherally to the cell bodies of the ganglia of the cranial nerves, which are motor in function. These axones bear the same relation to the cranial nerves that the cortico-spinal neurones, described above, bear to the spinal nerves which are distributed from the spinal cord.

III. Association or short segmental columns.

Characteristics: These fiber paths are both ascending and descending and serve to associate the various levels of the cord. They originate from tract cells of the gray matter of the same and opposite sides, pass up or down one or more segments in the white matter, and terminate in the gray matter of the same and of the opposite sides.



The phylogenetic history of the species shows (1) the long neurones to be a product of higher differentiation, (2) the length of the neuron varies directly with the phylogenetic development and the development of the individual. It is known that the independent activities of the cord vary inversely with the length of its fiber paths. In the higher forms of animal life, therefore, the cord is found to be rich in these association fibers, giving the animal a greater power of co-ordination of functions with the centers in the brain. The independence of the organism of its cord varies directly as its differentiation.

## CHAPTER XXXV.

### THE CRANIAL NERVES.

It has been thought best to describe the cranial nerves in outline form, and that the student may have access to a source of reference, a brief discussion of the anatomy of the nerves is also given. The cranial nerves are twelve in number and, with the exception of two, the olfactory and optic, they are quite similar to the spinal nerves in that they nearly all consist of afferent and efferent parts. In those nerves which are afferent in function the ganglia of their sensory portion are located irregularly, because of the many foldings which have occurred in the development of the brain.

**I. The Olfactory Nerve.**—1. Deep origin, limbic lobe and optic thalamus; 2. Superficial origin, the olfactory bulb; 3. Foramen of exit, cribriform plate of the ethmoid bone; 4. Distribution: There are three branches of this nerve, (a) the internal branch supplying the septum of the nose, (b) the middle branch the superior turbinated bone and the Schneiderian membrane, and (c) the outer branch supplying the lateral wall of the nose; 5. Function, sensation of smell.

**II. The Optic Nerve.**—1. Deep origin, optic thalamus, superior quadrigeminal body, and lateral geniculate body; 2. Superficial origin, the optic tract; 3. Foramen of exit, optic foramen; 4. Distribution, the retina; 5. Function, sensation of sight.

**III. The Oculo-Motor Nerve.**—1. Deep origin, fibers forming this nerve originate from the gray matter of the aqueduct of Sylvius subjacent to the superior quadrigeminal body; 2. Superficial origin, on the median side of the crus in front of the pons; 3. Foramen of exit, sphenoidal fissure; 4. Distribution,

this nerve supplies the levator palpebræ superioris and all of the muscles of the orbit except the superior oblique and the external rectus. It also supplies the intrinsic muscles of the eye, viz., the circular fibers of the pupil and the ciliary muscles for accommodation; 5. Function, somatic and visceromotor to the muscles supplied.

**IV. The Trochlear Nerve.**—1. Deep origin, fibers constituting this nerve arise from the aqueduct of Sylvius in the floor of the fourth ventricle at a level with the inferior quadrigeminal body and just posterior to the nucleus of the third nerve; 2. Superficial origin, at the outer side of the crus just in front of the pons. The fiber tracts cross, forming a complete decussation; 3. Foramen of exit, sphenoidal fissure; 4. Distribution and function, fibers from this nerve supply the superior oblique muscle, the cavernous plexus, and the lateral sinus. Its functions are motor and trophic.

**V. The Trigeminal Nerve.**—1. Deep origin, this nerve arises by two parts: (a) The ascending or sensory portion arises from the long tract of the medulla, which is continuous below with the substantia gelatinosa Rolandi, (b) the descending or motor portion arises just internal to the sensory portion in the superior mesial part of the floor of the fourth ventricle; 2. Superficial origin, in the lateral surface of the pons nearer the upper border than the lower; 3. Foramina of exit, (a) the ophthalmic division emerges through the sphenoidal fissure, (b) the superior maxillary division by way of the foramen rotundum, (c) the inferior maxillary division by way of the foramen ovale; 4. Distribution and function: This nerve is both motor and sensory to all the muscles of mastication except the buccinators. Fibers from this nerve are sensory (pressure, pain, and temperature) to the face, forepart of the scalp, eyes, and nose, a part of the ear, the anterior two-thirds of the tongue, and the dura mater.

**VI. The Abducent Nerve.**—1. Deep origin, just beneath the floor of the fourth ventricle; 2. Superficial origin, on the dorsal surface of the pons just above the pyramid; 3.

Foramen of exit, sphenoidal fissure; 4. Distribution and function, fibers of this nerve are motor to the external rectus of the eye.

**VII. The Facial Nerve.**—1. Deep origin, fibers forming this nerve arise from the mesial portion of the floor of the fourth ventricle, lateral and deep to the nucleus of the sixth nerve and internal to the spinal root of the fifth tract; 2. Superficial origin, on the posterior margin of the pons lateral to the sixth nerve, below the fifth, and internal to the auditory nerve; 3. Foramen of exit, through the internal auditory meatus, then through the aqueduct of Fallopius in the petrous portion of the temporal bone and then through the stylo-mastoid foramen; 4. Distribution and function: (a) The motor portion supplies the buccinator and stapedius muscles; (b) sensory fibers by way of the corda tympani pass to the anterior two-thirds of the tongue and convey specific sensations of taste; (c) autonomic fibers, vaso-dilator and secretory, are supplied to the submaxillary and sublingual glands by way of the corda tympani branch. This nerve also gives branches to the nasal and buccal mucous membranes.

**VIII. The Auditory Nerve.**—1. Deep origin, this nerve arises by two divisions, as follows: (a) The cochlear division arises from the spiral ganglion of the ventral cochlear nucleus and the tuberculum acusticum, (b) the vestibular division arises from the auditory nuclei and the striæ of the floor of the fourth ventricle; 2. Superficial origin, both branches pass out over the posterior border of the pons; 3. Foramen of exit, internal auditory meatus; 4. Distribution and function, the cochlear division supplies the macula acustica of the saccule, ampulla, and organs of Corti. The vestibular division supplies the macula acustica of the utricle and ampullæ of the semicircular canals. (See Physiology of the Ear.)

**IX. The Glossopharyngeal Nerve.**—1. Deep origin, fibers constituting this nerve arise from the nucleus ambiguus and fasciculus solitarius of the floor of the fourth ventricle; 2. Superficial origin, fibers constituting the nerve pass out from the medulla between the olivary body and the restiform body; 3. Foramen of exit, jugular; 4. Distribution and function: (a)

This nerve furnishes motor fibers to the stylo-pharyngeus muscle, (b) general sensation to the posterior one-third of the tongue, the soft palate, the tonsils, the upper part of the pharynx, the Eustachian tube and the tympanic cavity, (c) special sensation (sense of taste) to the posterior one-third of the tongue and surrounding mucous membranes, (d) autonomic fibers, vaso-dilator and secretory (nerve of Jacobson) to the parotid glands, and vaso-dilator to the tonsils and surrounding vessels.

**X. The Pneumogastric Nerve.**—1. Deep origin, nucleus ambiguus and fasciculus solitarius; 2. Superficial origin, just in front of the restiform body; 3. Foramen of exit, jugular; 4. Distribution and function: (a) Somatic motor fibers are distributed to the soft palate, pharynx, larynx, and muscles and joints of the larynx; (b) visceromotor fibers are supplied to the trachea, bronchi, œsophagus, stomach, and intestines to the descending colon, gall bladder, and gall duct, pancreas, and probably the liver; (c) visceroinhibitor fibers are supplied to the heart and to the muscles of the gall bladder; (d) vaso-dilator fibers are probably supplied to the vessels of the alimentary canal; (e) sensory fibers are supplied to the respiratory tract from the larynx down, the pharynx, the digestive tract, the pancreas, the gall bladder and duct, the liver, the concha of the ear, the internal auditory meatus, and meninges.

**XI. The Accessory Nerve.**—1. Deep origin, nucleus ambiguus and fasciculus solitarius and extending downward toward the sixth cranial nerve in the lateral margin of the horn; 2. Superficial origin, the accessory part comes out with the fibers of the vagus, the spinal part emerging from the lateral aspect of the cord below the origin of the tenth nerve; 3. Foramen of exit, jugular; 4. Distribution and function, the spinal portion of this nerve is motor to the sterno-mastoid and trapezius muscles and the accessory portion is distributed with the tenth nerve.

**XII. The Hypoglossal Nerve.**—1. Deep origin, fibers constituting this nerve arise from the lower mesial portion of the floor of the fourth ventricle and the groove between the olivary body and the medulla; 2. Superficial origin, between the olivary

body and the pyramid. The two roots unite in the foramen or just after leaving it; 3. Foramen of exit, anterior condyloid; 4. Distribution and function: (a) Sensory recurrent fibers are distributed to the meninges of the brain and (b) motor fibers are distributed to the intrinsic muscles of the tongue, the thyro-hyoid, the genio-hyoid, the hypoglossus and the genio-hyo-glossus muscles.

## CHAPTER XXXVI.

### PHYSIOLOGY OF THE BRAIN.

It is now generally considered by all physiologists that the cortex of the cerebral gray matter is the structural seat of consciousness. Every part of the cortex receives incoming or afferent fibers, which indirectly have come from some peripheral structure. The cortex also contains cells, the fibers of which are efferent in nature and carry outgoing impulses. Every part of the cortex is, therefore, an afferent ending and an efferent center, from which projection fibers are sent to other parts of the brain and to peripheral structure. Every part of the brain cortex may be considered as a termination of some afferent path and also as an efferent center or origin of some efferent path.

**The Brain a Complex Reflex Center.**—Because of its numerous afferent and efferent functions, together with its highly complex association fibers, which serve to connect various parts of the cerebral cortex, the brain cortex may be considered as a highly complex reflex center. It is quite definitely decided at present that that function which was once considered to be due to an automatic or spontaneous nerve action is effected by a highly complex reflex mechanism and that there is little, or most probably no, such thing as spontaneous or automatic action of the cells in the cerebral cortex, and that many of the so-called spontaneous actions of the brain, such as inspiration to thought and so on, are to be explained by the assumption that these conditions are the result of some afferent stimulation to cortical activity.

The structural nature of the cortex is such that it could be fitted only for reflex functions and not for the origination of automatic actions. There are no isolated neurons in the cortex, but all are connected in such a way that they would seem to be

fitted only to function as a reflex system. Any structural differences of the cells of the cortex, if such may exist, for the performance of such functions as thought, consciousness, and so on, lie in the ultimate chemical composition of the individual cells instead of any microscopic structural differences. "Since consciousness is effected through the intermediation of the cortical neurons, it

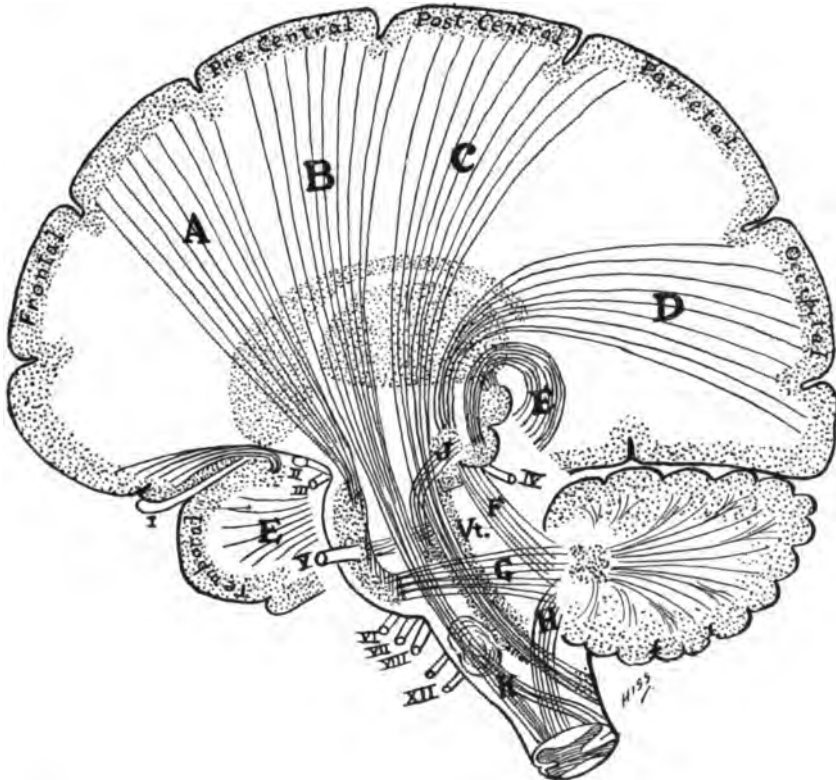

FIG. 31.—This figure shows the projection fibers of the cerebrum and cerebellum and a lateral section of the internal capsule. A, represents the tracts from the frontal gyri to the pons. The fibers are seen to continue to the cerebellum. This is the anterior cerebro-cortico-pontine tract; B, the motor tract from the pre-central area of the cerebral cortex; C, the afferent or sensory tract terminating in the area of the body senses; D, the visual tract going to the occipital region; E, the auditory tract; F, fibers of the superior peduncle of the cerebellum; G, fibers of the middle peduncle uniting with the fibers from the frontal gyri in the pons; H, inferior peduncle fibers of the cerebellum; J, fibers extending between the auditory nucleus and the inferior corpora quadrigeminal body; K, motor decussation; Vt., the fourth ventricle. The Roman numerals refer to the cranial nerves. (Modified from Starr.)



follows that, so far as our present knowledge goes, the physiology of the cortical neurons is the physiology of consciousness." (Burns.)

Further evidence of this conclusion may be had from a careful study of the brains of different animals in their phylogenetic development. The greater mental development of the higher forms of animals is associated with the greater complexity of their neuron connections and does not depend upon any observable structural differences in the cells of the cerebral cortex. Since the number of cells per cortical area varies inversely with phylogenetic development, or in other words since the same area of cortex of certain animals lower in the scale of life than man have a comparatively greater number of cells, it may readily be seen that the power of mental activity does not depend upon the actual number of cells in the cerebral cortex.

The number of dendritic connections in the cerebral cortex of any animal varies directly with its phylogenetic and ontogenetic development. From this it may be seen that the higher the animal in the state of development the greater is the complex association mechanism between the various centers of its cerebral cortex, and that during the development of the individual from infancy to maturity there is a constant increase in the complexity of its cortical neuron associations. In the higher forms of animal life the cortical cells are fewer in number, but the branching is greater. The greater mental activity of the higher forms of life is therefore considered to depend upon this rich interconnection between the various cortical centers, which makes possible a complex association of the different centers by way of these intervening fibers. It is by this means that the individual animal high in the scale of life is enabled to better analyze and correlate the various impulses that come to its cortex by way of its afferent system, and in this way its powers of consciousness are increased in proportion to other animals. Animals possessed with these powers of association of afferent impulses are better enabled to understand conditions of their immediate environment.

The reader is urged to study the chapter on "The Physiology of Consciousness," by Dr. Burns, in Part II.

**Effects of Extirpation of the Cerebrum.**—In the lower animals, such as the frog, for example, the effects of extirpation of the cerebrum are very slight. If the cerebrum of the frog be removed the animal seems to have lost very little of its powers to perform normal functions. It can jump, swim, and maintain normal equilibrium under normal conditions. If thrown into the water it will swim to some floating body, climb upon it, and act in every way as a normal frog would act. One thing, however, is practically always lost, even in the lower animals after decerebration, and that is the memory of past experiences. The power of instinct is usually lost, which renders the animal unable to perform certain functions as others of its kind may do.

**Effects of Decerebration in Higher Animals.**—The effects of extirpation of the cerebrum seem to vary directly with the scale of development. In dogs, for example, the extirpation of the cerebrum is usually fatal, and in those cases in which the animal does survive from a partial extirpation the results are always very marked. If only a portion of the cerebral cortex be removed the animal will usually survive, considering that the operation has been carefully performed, and after a period of weeks or months recovery from the severity of the symptoms almost always occurs. After a period of some months or a year or two the animal may completely recover and regain practically all of its normal functions. The amount of recovery depends, of course, upon the extent of the area of the cortex extirpated.

Pigeons are the animals commonly used for the study of decerebration effects, because the operation can easily be done and because they offer good opportunities for study. The pigeon after recovery from the operation shows many abnormal conditions, as follows: It is always drowsy and seems to take no interest in the affairs of its environment. It will stand for hours with head drooped, feathers ruffed, wings dropped, and eyes closed. Its motor powers seem to be well intact; that is, it has the power of movement and perfect regulation of its equilibrium, but seems to have no knowledge of approaching dangers, etc. If allowed to become hungry it will appear restless and sometimes

walk impatiently about the cage and will occasionally actually pick carelessly at the bars of the cage or at the floor, but there seems to be little or no volition involved in this act, as, for example, if corn be placed within its reach the dropping of the grains will often cause the animal to seemingly try to get the food by picking at the floor, but these attempts are never successful in getting food into the mouth, as it never actually strikes near the grain. The picking, therefore, in such cases is not really regulated by any voluntary control. When the animal is fed it is necessary to open the mouth, place the grain within the mouth, and force it into the oesophagus. Otherwise the animal cannot swallow. It will be remembered that the act of swallowing is divided into two parts, namely voluntary and reflex, the first of which concerns the passage of the bolus through the mouth and pharynx and is therefore under the control of the cerebrum. If the decerebrated pigeon be thrown into the air it can usually balance itself and fly without difficulty, and can even perch and maintain its equilibrium, but seems to have no power to initiate a change of position when confronted by conditions of danger, etc. If the decerebrated bird be placed upon a table it will often walk impatiently about, seemingly trying to find a way to get to the ground, but it seems to be unable to understand that it has any use of its wings. Such an animal was once known to hop from the table onto a box placed near the table and from there to the floor, which action would indicate that the animal had exerted some volition in the act, but when the animal was replaced upon the table it failed to repeat this act, and we must therefore question whether the first instance was purposeful.

Cerebral extirpation in monkeys offers a most excellent opportunity for the study of these effects. In the case of one monkey, in which the frontal and parietal lobes of the left side were removed, the animal was observed for a period of eleven years with the following results: The character of the animal was entirely unchanged and all traits seemed to remain unaltered. There was no loss of memory or intelligence, but the movements of the right side were affected until the time of death. There seemed

to be complete paralysis immediately following the operation, from which the animal gradually recovered, and in time it became able to use the muscles of its right limbs fairly well, but was always somewhat clumsy. The inability of the animal to co-ordinate the movements of the muscles of the right side may possibly have been due to an interference with the afferent system and its inability to receive sensory stimuli from the periphery. The animal used its right hand and right foot only when it had to do so, but learned after a time to put out its right hand for food when the left was tied. It would seem, therefore, that there is a possibility of the existence of motor fibers from both hemispheres of the cortex to the same group of muscles. This, however, could be explained by assuming that the functions of the muscles of the right side in this case were controlled by association fibers in the cord rather than by fibers of a direct descending column.

### LOCALIZATION OF CEREBRAL FUNCTIONS.

**Sensory Areas.**—The first valuable work along this line was done by Gall, who was the founder of phrenology. He determined that the cerebral cortex was not only that region which served as the structural basis of consciousness, but further assumed that various areas had specific functions, such as judgment, intelligence, memory, imitativeness, and a great many others. These theories were overthrown by Flourens, who proved Gall's conclusions to be fallacious, both experimentally and theoretically. Flourens concluded that the cerebral hemispheres functioned as a whole in the regulation of consciousness, intelligence, and will.

Modern research workers have found that in general Flourens was right and that it is the co-operative functioning of the various areas of the cerebrum which determines the consciousness, or in fact all psychical conditions, of the individual at all times. Since the work of Flourens it has been shown that he was wrong in assuming that there are no functionally differentiated areas, and many such centers are now quite definitely located.

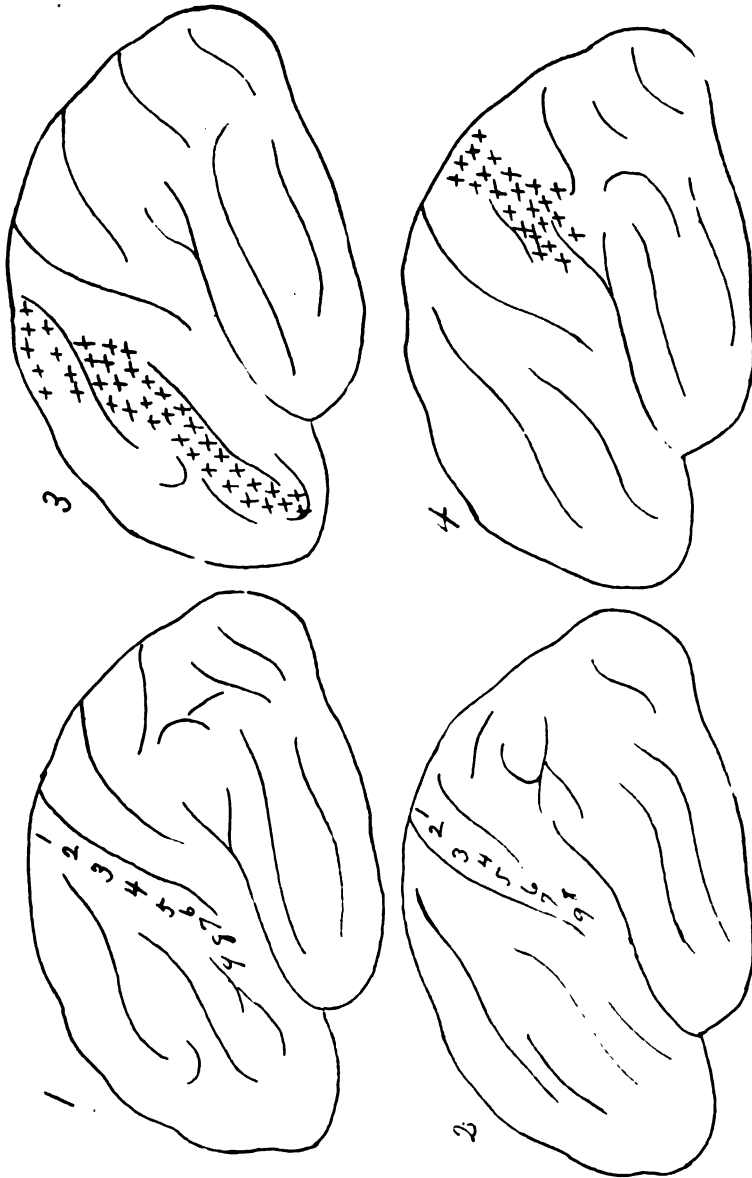

FIG. 32.—DIAGRAM OF THE SENSORY-MOTOR AREA. 1. Primary motor area: 1, hip; 2, trunk; 3, shoulder; 4, arm; 5, wrist; 6, fingers; 7, face; 8, lip; 9, larynx. 2. Primary areas for common sensations. Number as 1. 3. Motor overflow areas. 4. Overflow areas for the common sensations. (Courtesy of Dr. Burns.)

**Broca's Area—Center for Speech.**—It was shown by Broca, a French physician, in 1861 that a certain area, the third frontal convolution of the left hemisphere, was constantly associated with aphasia or loss of the power of speech in right-handed individuals. It has been so constantly shown since that time that pathological lesions of this area are associated with this affection that this center has since been known as the area of Broca. Broca, however, was not the first discoverer of this center, but only confirmed the findings of two others, viz., Bouillaud and Dax. It has since been shown that in left-handed individuals the corresponding area of the opposite side is affected in aphasia and that ambidextrous persons seldom, if ever, suffer from aphasia.

**Kinds of Aphasia.**—Since the result of the functioning of the different areas of the cerebrum and the correlation of these is expressed by speech the study of this function, or rather any abnormality of this function, often throws much light upon the general functions of the cortex and its various parts. The term aphasia is, therefore, a somewhat general term and refers to that condition in man which renders him unable to properly interpret or express his ideas in speech. Aphasia is generally divided into two forms, as follows:

**Motor Aphasia or Broca's Aphasia.**—This condition was first described by Broca as that in which, although the individual could understand what was said to him, he was unable to speak. The pathological lesion causative of this condition, as stated by Broca, was to be found in the third left frontal convolution. The general intelligence of the patient is not necessarily involved by such lesions.

**Sensory Aphasia or the Aphasia of Wernicke.**—In this condition the patient's ability to understand spoken words is materially reduced or even destroyed, and his general intelligence is also impaired. The area, lesions of which is responsible for this trouble, has been located by Wernicke and is said to cover rather a large area of the cortex. It is known as Wernicke's area and lies in the supramarginal and angular gyri and the posterior portion of the first and second temporo-sphenoidal convolu-

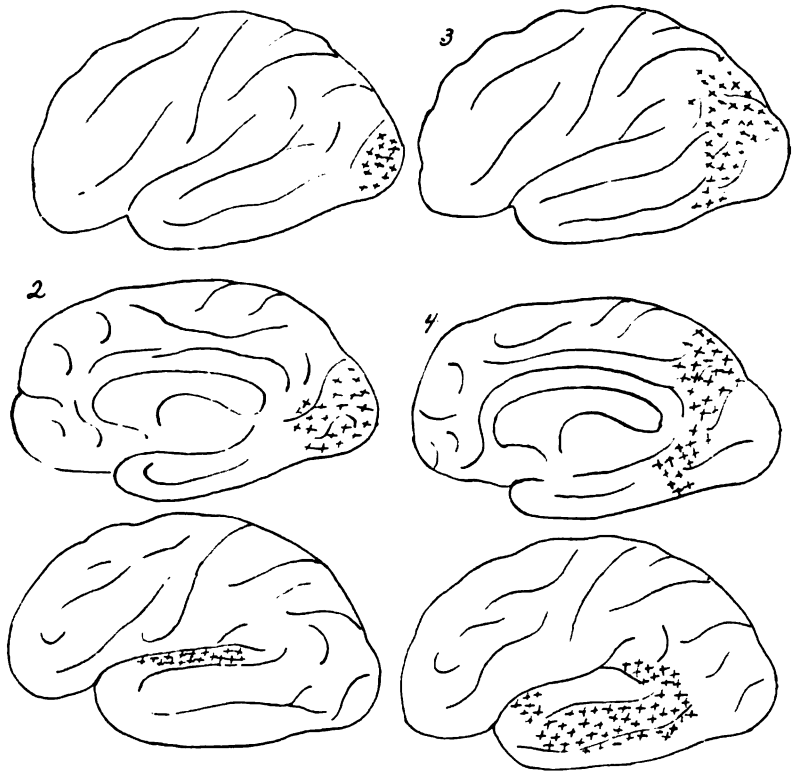

FIG. 33.—DIAGRAM OF THE SENSORY AREAS. 1, lateral aspect of hemisphere, primary visual area; 2, mesial area of hemisphere, primary visual area; 3, lateral aspect of hemisphere, visual overflow; 4, mesial aspect of hemisphere, visual overflow; 5, primary auditory area; 6, auditory overflow. (Courtesy of Dr. Burns.)

tions. In case of inextensive lesions of these areas there may be only a very limited interference with the power of speech, but in the extensive regions there may be total inability of speech with severe impairment of the general intelligence. The patient may be able to speak, but does not understand what is said to him. There are, however, conditions in which the patient suffers both from sensory and motor aphasia and in which conditions he can neither speak nor understand spoken words.

Another condition sometimes observed is alexia, or word blindness. It is the inability to interpret written or printed

words or phrases. This condition is also known as optical or visual aphasia. Another form of aphasia closely associated with alexia (possibly the same thing) is musical aphasia or music blindness. It is the inability to interpret printed music notes. Such individuals can often play well and appreciate music thoroughly but have limited or possibly no power to interpret music from the printed sheet.

Anarthria or aphemias may be said to be another form of aphasia in which there is an impairment of the powers of expres-

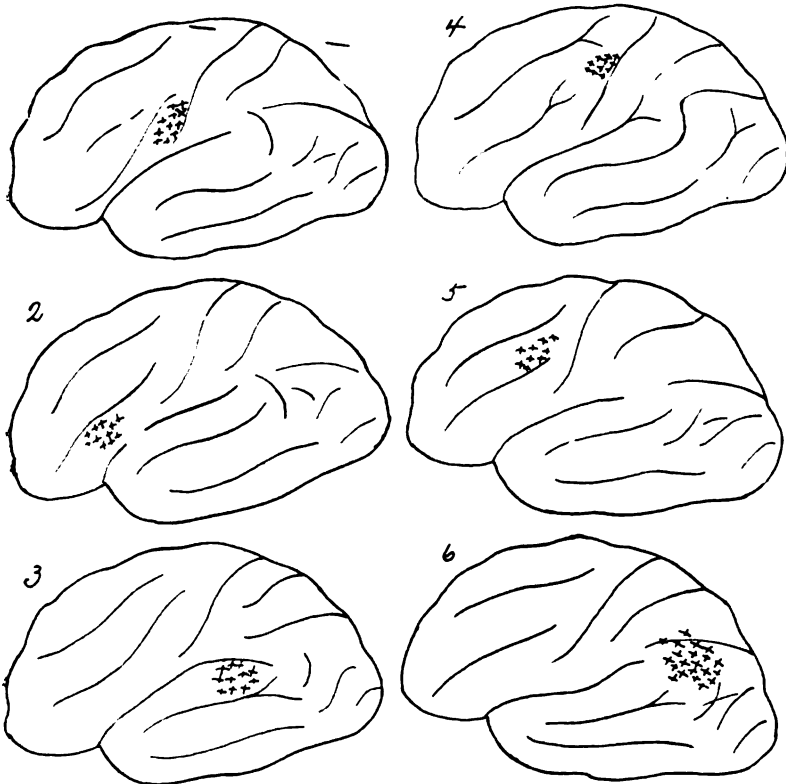

FIG. 34.—THE LANGUAGE CENTERS. 1, Motor area for the muscles concerned in speech; 2, speech center, for the co-ordination of the movements of the muscles of speech; 3, center for the memories of heard words; 4, primary motor for the movements of the fingers, etc.; 5, writing center; 6, center for the memories of seen words. (Courtesy of Dr. Burns.)



sion, the ability to understand spoken or written words, the intelligence being usually unaffected. This condition has been associated with pathological lesions of the white matter of the external capsule.

It may be that these motor functions are controlled by specific centers or areas and it has been suggested that other areas, namely, the ascending frontal convolutions, in addition to the one above mentioned, is concerned in these cerebral processes causative of movement, but it is most likely that these complex mechanisms, such as speech, depend upon a much more extensive association for their neural basis. It is highly probable that a word or phrase which expresses an idea involves all or nearly all of the various sensory centers in its process of effecting complete understanding. It is the power of the individual to associate and correlate the results of activities of many or all of these various centers which give completeness to the understanding. It has been stated that even Brocas' area is not a specific center by any means. "The cases described by Broca of motor aphasia are really cases of sensory aphasia from lesion of Wernicke's area, combined with anarthria due to subcortical injury of the fibers of the internal capsule. The statement that there is no loss of intelligence in these cases of so-called motor aphasia does not bear investigation." (Starling.) From this it will be seen that those who would describe specific areas to any particular function of the cerebral cortex have arrived at such conclusions rather hastily, for there does not seem to be sufficient clinical and experimental evidence to bear out their statements. On the other hand, it would seem that in general the functions of the cerebral cortex depend, as we have stated in the beginning of this chapter, upon the completeness of the dendritic connections and the association of the various sensory areas of the cerebral cortex.

**Motor Areas of the Cerebrum.**—The localization of the motor areas is much less difficult than the localization of the sensory areas. In case of the motor areas it is possible by stimulation of the exposed cortex artificially to determine what muscles are involved and thus determine the functions of the regions

stimulated. The results of experimental work done by Shafer, Farrier, and others upon dogs, apes, and other animals, and the results of surgical work on human individuals have quite definitely located the motor areas of the cerebral cortex. "This motor area surrounds the central sulcus of Rolando and extends inward upon the mesial surface of the cerebrum." By the careful application

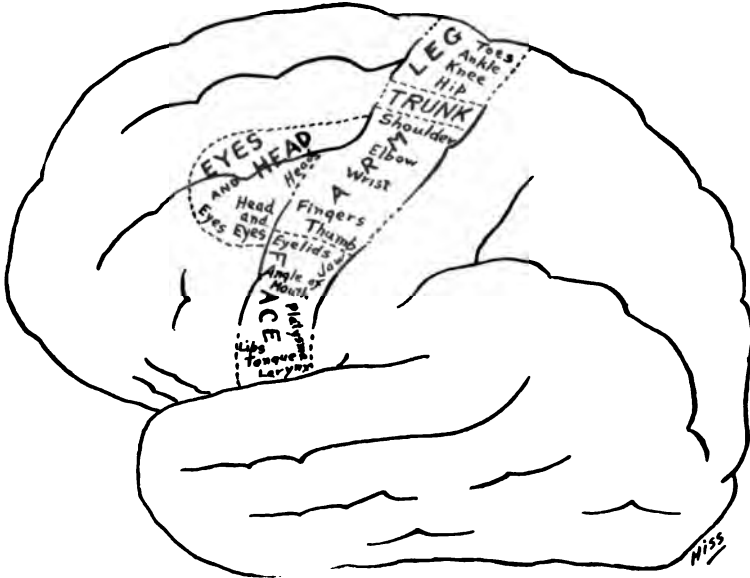

FIG. 35.—Showing the motor areas of the human brain. (Brubaker, after Mills.)

of electrical stimulus by means of platinum electrodes the smaller areas regulating the activities of certain muscles or groups of muscles may be accurately located. The results of recent work along this line done by Sherrington and others show that the motor area is located anterior to the central convolution and corresponds to those regions from which the pyramidal tracts arise. That this is the location of the motor centers regulating the voluntary musculature has been confirmed by the clinical experience of many observers, who have studied the pathological changes in the brain in cases of muscular paralysis.

**Course of the Efferent Motor Fibers.**—Impulses from these cortical centers, according to Howell, take the following course from the cortex: “1, Corona radiata; 2, internal capsule; 3, peduncle of the cerebrum; 4, pons varolii, in which they are broken into a number of smaller bundles by the fibers of the middle peduncle of the cerebellum (brachium pontis). In this region, also, some of the fibers cross the mid-line, to end in the motor nuclei of the cranial nerves: Third, fourth, fifth, sixth, and seventh; 5, anterior pyramids; 6, pyramidal decussation; 7, anterior and lateral pyramidal fasciculi in the cord.” These fibers terminate about the cell bodies of the somatic efferent neurons in the cord or about corresponding cell bodies of the cranial nerves. The exact mechanism of the association of the cortico-spinal fibers with the spino-muscular fibers is not definitely understood. It is believed that in some cases the axons of the cortico-spinal neuron may terminate directly in relation with the dendrites or the cell bodies of the spino-muscular neurons. They may also terminate about intermediate fibers, which serve to associate the cortico-spinal neurons with the musculo-spinal neurons.

It may be seen, therefore, that the nervous mechanism associating the cortex of the brain with the voluntary muscles consists of two parts: First, the cortico-spinal neuron, commonly known as the upper motor neuron, which carries the message from the cells of the cerebral cortex to the motor cells in the cord or to the motor cells of the cranial nerves; second, the spino-muscular, commonly known as the lower motor neuron, which carries the impulses to the muscles supplied. The cortico-spinal system seems to exercise an inhibitory function over the cell bodies of the lower motor neurons, preventing their excessive activity from stimulation by way of reflex from the afferent spinal nerves. The functions of these fibers will be illustrated more in detail in another chapter, which considers the various symptoms resulting from lesions of the different pathways.

### FUNCTIONS OF THE CEREBELLUM.

Like the cerebrum, the cerebellum is a complex reflex arc, it having many nerve connections with the cord and with other parts of the brain. It is connected with the cord and the medulla by way of the inferior peduncles and receives fibers from the following structures: The cerebro-spinal fasciculus, nuclei gracilis and cuneatus, and Gower's tract, which transmits the deep



FIG. 36.—CROSS SECTION OF LOBULE OF CEREBELLUM OF WOMAN OF ABOUT 30 YEARS. Semi-diagrammatic. 72 diameters. (Courtesy of Dr. Burns.)

sensibilities from the muscles, joints, etc. It has connections with the vestibular branch of the eighth nerve, by which it in some way seems to be associated with co-ordination. It also has connections with the tenth, fifth, and possibly optic nerves.

The result of extirpation of the cerebellum is total inco-ordination and possibly some loss of the deep sensibilities, but there is no apparent loss of sensations, nor are there any signs of psychic disturbances. There is very little known positively regarding its functions, but the following theories are sustained by experimental and clinical evidence: 1. Co-ordination of muscular movements in locomotion; 2. Center of muscle and joint sense, and; 3. It probably has something to do with the augmentation of motor activities by way of the pyramidal tracts.

## CHAPTER XXXVII.

# EFFECTS OF PATHOLOGICAL LESIONS OF THE SPINAL CORD.

**Upper Motor Neuron Lesions.**—The fibers extending from the nerve cells of the various brain centers to the various cell bodies located in the cord are known as cortico-spinal or upper motor neurons. It is the function of these nerve fibers to carry impulses from the brain centers to the nerve cells located at various levels of the cord. As has been pointed out in previous chapters, these fibers exert an inhibitory influence on the cell bodies of the cord from which impulses are sent to peripheral structures. This fact should be borne in mind in order to understand the different symptoms which result from lesions involving these fibers.

**Cortico-Spinal Paralysis.**—Paralysis resulting from pathological lesions of the upper motor neuron are characterized by certain symptoms which may easily be understood when the functions of these fibers are understood. The symptoms of lesions of the cortico-spinal neurons are as follows:

1. The muscles involved in the paralysis are not completely paralyzed. This is because the cell bodies in the cord (cells of the lower motor neuron) are not entirely shut off from their cortical connections by such a lesion. It is probable that the lesion is not sufficiently extensive to involve all of the descending fibers of the cortico-spinal system of one side and, even if this should be the case, the descending fibers of the opposite side by their crossing at the different levels furnish some stimulus to the cells of the cord which supply impulses to the musculature.

2. All muscles of the part affected by the paralysis are equally involved. This, as has been explained above, is due to the exten-

sive involvement of many segments of the cord, since the lesion affects fibers of the upper motor neuron, which are distributed to many segments.

3. The musculature of the part involved in the paralysis is spastic, the joints are stiff and movement is difficult. This condition is explained by assuming that the inhibitory action of the cortico-spinal neurons is cut off and the cell bodies of the spino-muscular or lower motor neurons function excessively, and from this increased amount of stimulation to the muscles by way of the spino-muscular neurons the tone in the muscles is increased beyond normal. The cell bodies of the motor fibers of the cord are probably stimulated to activity by afferent impulses coming in from the periphery and, since there is no inhibition exerted by the descending fiber paths, the cells of the lower motor neuron are constantly receiving stimulation without any inhibitory influence.

4. The reflexes are exaggerated. This is because of the decreased inhibition from the cortico-spinal neurons, which condition allows an excessive stimulation of the cells of the lower motor neuron, when the afferent system is stimulated by the tapping used for testing the reflex.

5. There is no atrophy except from disuse. This is explained by assuming that the lower motor neuron, which is not affected, regulates the trophic influences of the tissues supplied. By this explanation we are assuming that the function of trophism is regulated by way of the spino-muscular neuron from the cell bodies in the anterior horn of the cord.

6. There is no muscular flabbiness. This negative symptom is often of much value in differentiating those paralyzes which may possibly result from lesions involving the fiber paths of the cortico-spinal neuron and also some of the cell bodies in the cord from which the fibers extend, which constitute the spino-muscular neuron.

7. The circulation to the part involved is usually impaired and the skin surfaces of these areas are often bluish and cold. It is not easy to explain just how these symptoms result from lesions of the upper motor neuron, but it is most likely that they

are present as a result of the spasticity and the lack of movement, which decreases the circulation of the blood. It is not probable that the smooth muscles of the walls of the blood vessels have lost their tone, but it may be that these muscles, like the striated muscles, are spastic, which would therefore by vaso-constriction allow a decreased blood supply to the part.

8. There is usually a tendency to œdema. This condition probably occurs as the result of the decreased venous drainage from the affected part, which in turn is due to the decreased muscular exercise and the increased resistance offered by the spastic musculature through which the veins extend. There is also for these same reasons a decreased lymph flow from the parts involved.

9. Sensory disturbances, when they are present, signify an involvement of other parts of the cord than the descending motor pathways. It usually happens that sensory symptoms come on as the disease progresses and are seldom present at the outset unless the condition has been due to trauma of the cord.

Paralyses of this type occur in all forms of cerebral disease, such as the hemiplegias, etc. It also occurs in lesions of the cord, such as transverse lesions resulting from trauma, hemorrhage, tumors, cord inflammations, Pott's disease, and so on.

**Spino-Muscular Paralysis.**—The spino-muscular neuron is that which extends from the cell bodies located in the anterior horn of the gray matter of the spinal cord to the striated muscles. This is commonly known as the motor or lower motor neuron. Its function, as has been explained above, is that of carrying impulses from the cord to the structure supplied. Paralyses of the structures supplied by these neurons may result from pathological lesions or trauma involving the cell bodies or the nerve trunks which carry the axons from these cell bodies to the muscles. The symptoms characteristic of lesions of the spino-muscular neuron are as follows:

1. The muscles affected are completely paralyzed from the time the paralysis first begins. Recovery is very slow and is never complete. This is because the cell bodies of that area of the

cord from which the axons arise, which are distributed to the muscle, are usually completely destroyed and seldom, if ever, regenerate.

2. All muscles of the paralyzed area are usually not affected, but some remain in good condition. This may be explained by assuming that the unaffected muscles are supplied by axons from cell bodies in the cord, which lie at different levels from the involved area.

3. There is no spasticity of the muscles affected by the paralysis and the joints of the affected side are relaxed instead of being stiff, as in lesions of the upper motor neuron. The movement of the joints is usually freer than in normal conditions. This is due to the decreased nerve supply to these structures, which decreases the tone of the muscles involved in the paralysis and the muscles about the joint.

4. The reflexes are diminished or lost according to the extent of the lesion. This is explained by the break in the reflex arc caused by the degeneration of the motor cells of the cord.

5. There is always some atrophy of the muscles involved in the paralysis, because of the reaction of degeneration following the cord lesion, which decreases the trophic influences to the structures supplied and which also decreases the nerve supply to the vessels, thereby impairing the blood supply to the part.

6. The muscles of the affected part are always flabby, which is explained by the decreased tone of the muscles caused by the lack of motor impulses to the muscle fibers. The extent of the flabbiness depends upon the extent of the cord involvement. There is seldom any improvement from this condition.

7. The circulation to the part is always poor, which may be due to lack of exercise, decreased venous drainage, or possibly it may be due to an involvement of the cell bodies of the anterolateral part of the gray matter of the cord, from which the axons arise, which are destined to supply the smooth muscle of the arterial walls. The lesion may in this way affect the tone of the muscles of the blood vessels. The skin is usually bluish and cold, which symptom is more marked than in cases of paralysis resulting from cortico-spinal neuron lesions.



8. Oedema is not common in this type of paralysis, as there is usually no great resistance offered to the venous drainage, but there is usually a clammy perspiration, which may result from an involvement of the lower motor neuron fibers, which regulate the secretion of sweat.

9. Sensory disturbances in this type of paralysis are not necessarily present. There is usually no sensory disturbance unless the lesion which involves the anterior horn cells of the cord also extends to and involves the ascending columns of the cord or, if it be a lesion of the nerve root, it may possibly involve the ganglia of the posterior root and in this way cause sensory disturbance.

Paralyses due to lesions of the anterior horn cells or their nerve trunks and their axones and characterized by symptoms as stated above are to be found in the following conditions: 1. Infantile spinal paralysis, which is a disease causing degenerative changes of the anterior horn cells of the cord; 2. Amyotropic lateral sclerosis, which is a disease affecting the lateral columns of the cord; 3. Myelitis or general inflammation of the cord, and syringomyelia. Symptoms of this type of paralysis are also sometimes observed as a result of tumors or hemorrhage occurring within the cord and occasionally by neuritis, which involves the nerve root or nerve trunk.

**Paralysis Resulting from Lesions of Both Gray and White Matter.**—In some conditions the pathological lesions involving the cord are so extensive that both the gray and white matter are affected and the symptoms therefore are of the upper and lower motor neuron type; that is, symptoms referable to both conditions may be observed. In this case it is often difficult to determine from the symptoms the locality and extent of the pathological lesion causative of the trouble:

1. In cases of this type there are usually symptoms of a progressive paralysis. All of the muscles of the affected part are paralyzed and both sides are usually involved.

2. Sphincter disturbances are nearly always present, which indicate that the pathological lesion has involved the antero-

lateral gray matter of the cord, causing degenerative changes in the cell bodies supplying the efferent visceral autonomic fibers to the sphincters of the rectum and bladder

3. Trophic disturbances are nearly always present, which, as has been explained above, result from the degenerative changes occurring in the anterior horn cells of the spinal cord. In addition to these symptoms in case of lesion involving gray and white matter there will be symptoms of both types, as have been given above.

**Paralysis Due to Trauma to the Cord.**—In cases of injury where the cord is affected by bruises, etc., it is usually possible to determine by the nature of the symptoms the extent of injury which has occurred: 1. There is total paralysis below the level of the injury; 2. The muscles supplied by all nerves which originate from the cord below the lesion are spastic, as in case of cortico-spinal lesions, but in this instance the musculature of both sides is affected. The musculature of the two sides may not be paralyzed to the same extent; 3. The reflexes are increased as in lesions of the upper motor neuron; 4. Sphincter disturbances are always present, but they may be due to either an increased or decreased tone of the smooth muscles of the rectum and bladder and there may, therefore, be either a continence or incontinence of urine and feces as a result.

**Spinal Shock.**—Spinal shock may be defined as “A depression of the functional power of the nervous tissue distal to the lesion, a depression which may extend far from the actual seat of injury and manifest itself by various phenomena.” (Stewart.) Spinal shock is a condition which occurs in all animals after a section, partial section, or other traumatic injury to the cord. The symptoms of spinal shock are as follows:

1. The effect of spinal shock is always greatest in those structures supplied by nerve fibers which originate from the cord peripheral to the point of injury. Sherrington states that “Spinal shock appears to take effect in the aboral direction only.”

2. The reflexes are all lost for a time, which time varies directly with the phylogenetic development of the animal. This

is also true for other effects of shock, as the amount of involvement and the length of time before recovery from the effects is least in the lower forms of life and greatest in monkeys and man. "If in a frog the spinal marrow be divided just behind the occiput, there are for a very short time no diastaltic actions in the extremities. The diastaltic actions speedily return." (Marshall Hall.) The "shock" time in the cat is from five to twenty minutes and slightly longer in the dog, while in case of monkeys the symptoms of the shock last for weeks or months and in the human individual the symptoms last even longer than this. For the relations of the effects of the osteopathic lesion to spinal shock see Part II, of this book.

**Effects of Complete Division of the Cord.**—Complete division of the cord has often been practiced for the purpose of studying the effects in animals, and the same thing has resulted from traumatic injury in human individuals. The symptoms of complete transection of the cord are as follows: 1. There is total paralysis below the level of the section and the muscles are completely relaxed. This, however, is not always true in the lower animals, as in many cases complete transection of the cord produces only the symptoms of spinal shock; 2. The paralysis which always occurs in all musculature supplied by nerve fibers, which originate from the cord below the region of transection, is symmetrical and both sides are involved; 3. The reflexes are lost; 4. There is retention of urine; 5. There is vaso-constrictor paralysis and priapism; 6. All sensation is lost to pain and temperature and usually to touch. These symptoms are always present, and if not found to exist it may be immediately decided that the cord is not completely sectioned.

**Sensory Disturbances Resulting from Cord Lesions.**—

The physiological perversions of afferent sensations which may result from cord and nerve lesions may be classified under two general headings, namely, excitatory, or those which produce an increased functional activity of the brain, cord, or peripheral structures, and inhibitory, or those which produce a decreased functional activity of these structures.

Under the excitatory disturbances we may include those sensations which cause the animal to be more conscious of its external environment as well as the conditions of its own body. These sensations are of many different kinds, such as visual, olfactory, auditory, gustatory, pain, temperature, pressure, and the internal sensations such as hunger, thirst, etc. There may also be an increased activity of those afferent fibers which take part in producing reflex effects, which in turn causes increased activity of the efferent fibers, and therefore accentuated physiological activities of the structures supplied by these efferent fibers may result. As an example of this, attention may be called to the rigidity of muscles supplied from a certain segment which is effected reflexly by some visceral disturbance. The converse of this condition sometimes results when visceral disturbances result from increased sensory stimulation from some peripheral or joint surface. We believe this is the explanation of the way in which bony lesions are often the cause of visceral disturbances. It has been shown that innominate lesions experimentally produced are frequently followed by diarrhoea, which may be explained by the above statements.

Under the inhibitory disturbances we may include those sensations which cause the animal to be less conscious of its environment or its bodily condition. It is believed by some authorities that special fibers exist for the transmission of conscious sensations, but there is little or no positive evidence of the existence of such paths. It is most likely that sensations which result in that condition we call consciousness are carried by several or possibly all of the afferent pathways. It can be readily seen, therefore, that anything which interferes with the normal conduction of the afferent fibers decreases consciousness. There is also a decreased activity of those bodily functions which are regulated reflexly by afferent impulses and such functions as visceromotion, vasomotion, secretion, trophism, etc., are affected by lesions interfering with the normal conduction of afferent impulses.

**Conditions Causing Excitatory Sensory Disturbances.—**Various conditions which cause excessive irritability of the dif-

ferent sensory regions of the cord may cause a condition of hypersensitiveness of the skin surfaces, causing an augmentation of impulses received from the skin. "The irritation in the cord may be so great as to lead to hallucinations of sensation; that is, to the perception of sensations in the skin which are set up in the cord and do not really come from the skin similar in origin to the tingling felt in the little finger on compressing the ulnar nerve at the elbow." In early stages of certain diseases of the cord in which there is irritation following a congestion the patients often complain of various sensory disturbances, such as numbness, tingling, etc. In some cases the perverted sensations consist of pain, sensations of pressure or burning, and sometimes of excessive temperature sensations, either cold or heat. These sensations are felt in the referred areas of the skin corresponding to the segment of the cord from which their nerve supply is derived. The term *paræsthesia* is given to this general condition of perverted sensations.

**Conditions Causing Inhibitory Sensory Disturbances.—**

The condition of decreased sensitiveness to afferent impulses is known as anaesthesia and may be a result of many causes, as follows: 1. Degenerative changes of the cord which extend to and involve the ascending columns; 2. Pathological changes involving the ganglia of the posterior root; 3. Inflammation, such as neuritis, affecting the nerve trunk, and in some cases lesions of the skin which prevent the reception or initiation of impulses from sensory surfaces.

The results of such lesions may be quite varied. The various sensations may be perverted or lost, such as pain, tactile, temperature, and others, and there is also a decreased ability of co-ordination known as ataxia. These conditions result because of the imperfect transmission of the afferent impulses either from the peripheral surface to the cord or from the cord to the brain.

# SECTION VIII

---

## PHYSIOLOGY OF THE SPECIAL SENSES



## CHAPTER XXXVIII.

### CLASSIFICATION OF SENSATIONS.

The term "sense organ" applies to a mechanism concerned in the mediation of some specific sensation and consisting of the following structural parts: 1. The peripheral part, or end organ, which receives the stimulus; 2. The afferent part, which transmits the impulse to the central nervous system; and 3. The brain centers, which are active in rendering the individual conscious of the nature of the stimulating medium causative of these changes. A structure consisting of these three parts constitutes what is known as an afferent unit.

**Old Classification Inadequate.**—The classification found in the earlier texts on the physiology of the special senses is inadequate, because physiological research has only recently determined that a far greater number of the so-called organs of special sensation actually exist than had previously been recognized. The old classification recognized only five special sensations, viz., sight, hearing, smell, taste, and touch. We now know that in addition to the first four there are a great many more which surely have a right to be considered as sense organs transmitting specific sensations, since structurally and functionally they correspond to the requirements of a sense organ as defined above. The so-called special sense of touch has now been found to consist of many specific sensations, such as pressure, temperature, pain, and probably many others.

The so-called specific sensations are only a result of the demands of function, which have, through the ages of phylogenetic development, formed some senses more perfectly than others for the purposes of protection, etc. The sensations, therefore, vary in their degree of specificity from the simplest to the most



specific, and no definite distinction can be accurately drawn between the common and special senses.

**The Sense of Pain.**—That the influences of the evolutionary factor which have been active in producing this special sense may be seen, it seems well to inquire into the function of pain. The function of pain is that of protection and not punishment. When it is necessary for a part to rest, painful sensations are the media by means of which the individual is made to give rest to the part affected. An example of this may be noted in the case of tubercular joints, the pain being relieved just as soon as the part is placed in a firm cast which prevents movement. The demand of function in this case is rest, and the painful sensations are the media by means of which the individual is forced to rest the part. This, then, is a protective reflex, the painful sensations reflexly inhibiting the movement of the joints involved. Starling interestingly observes that "The reflexes which are excited by painful or nocuous stimuli must be regarded as prepotent in that their inhibitory effect on other reflexes is more marked than that produced by any other quality of stimulus. In the struggle for existence the reaction to nocuous stimuli must predominate over those due to any other kind, since it is essential for the survival of the animal that the stimulus should be removed or avoided, so that the animal should escape from its injurious effects." It may be seen, therefore, that we cannot separate the special senses from the somatic and visceral reflexes. The whole nervous system with all of its parts has been developed according to a general plan, and that plan has been determined by the demand of body functions.

**Internal and External Sensations.**—According to one method of classification all sensations are divided into two groups, viz., external or peripheral sensations and internal or central sensations. Under the first group sight, hearing, smell, taste, pressure, and temperature sensations are classified, because of the fact that their end organs are peripherally located. Under the second group those sensations are included which are projected from the interior. They constitute the following sensations: Pain, muscle

sense, equilibrium, hunger, thirst, sexual sense, fatigue, position, itching, tickling, and probably many others.

**Theory of Specific Nerve Energy.**—By the doctrine of specific nerve energy it is maintained that each afferent unit has only one function, that of receiving and transmitting its own specific quality or kind of sensation. The optic unit, for example, has the power of transmitting only visual sensations, and the olfactory unit has the power of transmitting only sensations of smell, etc.

As evidence of the specific theory of nerve conduction the following may be given: 1. That artificial stimulation of the central end of the optic nerve causes sensation of light has been shown experimentally; 2. It had been shown that stimulation of the central end of the auditory nerve artificially, produces the sensation of sound; 3. It has been shown that stimulation of the central end of the corda tympani experimentally, produces a sensation of taste. Many other similar examples could be given; 4. Mechanical pressure when applied to peripheral nerves may cause the loss of certain sensations, such as temperature, either heat or cold, pain or pressure, etc., without affecting others. Any one or more may be retained while others are lost. Such phenomena can be explained by assuming the existence of specific properties of the different afferent units; 5. It is also known that similar conditions to those just described may occur from traumatic or pathological lesions of the spinal cord, which also may be explained by assuming that according to this theory only certain tracts in the cord are involved, which tracts may be responsible for the transmission of the specific impulses which are lacking; 6. That regeneration of nerve tissue usually restores the lost specific function is also evidence of this theory.

Since there is sufficient evidence to show that such a physiological specificity does exist, the question of the cause of such specificity naturally arises. Obviously this must be explained by assuming that one or more of the three parts of the afferent unit are responsible or that it is due to the nature of the stimulating

medium. We will endeavor to arrive at a conclusion by elimination:

1. That the specificity is not due to any structural peculiarity in the nerve fiber, we have the following evidence: (a) no histological differences in structure have been demonstrated which could be responsible for these differences in function; (b) different fibers may produce the same effects when allowed to regenerate in such a way as to form functional association with the proper centers and end organs (see evidence in paragraph following). It does not seem probable that specificity of function could be due to some specific kind of chemical or physiological change occurring in the cell or fibers during conduction, because the only physical or chemical changes known to occur during conduction or stimulation are the electrical changes, which seem to be the same for all nerves, and an increase in temperature, which probably results from the metabolic changes occurring in the nerve cell. Metabolic changes are known to occur in nerve cells, but no specificity of metabolic change is known to be associated with the different nerve cells or fibers.

2. That some structural peculiarity or adaptation of the end organs is responsible for the specificity in many cases we offer the following evidence: (a) That if one specific nerve be cut and allowed to regenerate to a different end organ, after regeneration stimulation of the nerve produces the function of the new end organ (for example, the crossing of the cranial and spinal autonomic nerves to the salivary glands after regeneration produces opposite effects when stimulated; see nerve supply to salivary glands); (b) that certain afferent units are capable of reacting to only those stimuli which affect their end organs. For example, sensations of taste are excited only by fluid substances, and the different end organs of taste react only to certain stimuli (see sense of taste). The same is true of the sense of smell, as only substances in the gaseous form have the power of arousing such sensations. In these cases the specificity seems to be due almost wholly to the end organs. Further evidence of the function of the end organs

as a specific receptor may be observed in the specific receptive areas of the skin to heat, cold, pain, etc.

3. That the greater number of specific sensations are due to some structural and functional peculiarity of the brain centers, which receive the transmitted sensation, seems to be well established. As evidence of this we have the following: 1. If the conducting pathway is lacking, stimulation of the end organ produces no specific effect; 2. If the center is lacking the stimulation of neither the end organ nor the nerve trunk is followed by consciousness of the specific sensation.

It may be seen that all three of these parts of the afferent unit are absolutely essential to the normal transmission of normal specific sensations. Specific sensations may be transmitted artificially if the end organ is lacking, but there can be no conscious reaction without the cortical centers and their associations being intact.

**Measurement of Nerve Force.**—Physiology will not have a right to be considered as a separate and independent science until we can measure physiological functions and express those effects in numbers. This has been done or, we should say, a beginning has been made in regard to the physiology of nerve tissue. Relative to the measurement of nerve force the following facts have been shown: 1. Motor effects resulting from artificial stimulation may be increased by increasing the strength of the stimulus. The same is true in a general way for all efferent nerves. If, for example, a stimulus be applied to the peripheral end of the vagus nerve and the secretion of gastric juice carefully observed it will be seen that the amount of secretion varies directly with the strength of the stimulus applied (up to a certain limit) and the time of the application of the stimulus; 2. Secretory effects produced by reflex stimulation vary directly in quantity with the time and intensity of the stimulus applied. It should be possible to measure efferent and reflex effects in ergs of work or dynes of force, or both, and in this way determine exactly the relation between the nerve energy applied and the amount of work done. Conscious effects should also be conditions measurable and com-

parable to the amount of afferent sensation causative of the conscious effects.

**Cutaneous Sensations.**—The cutaneous sensations have, from the results of recent observations, been divided into two general groups, viz., the protopathic sensibilities and the epicritic sensibilities. The former group includes those sensations of pain and extreme temperature variations. These sensations are not well localized and the reaction is not adjusted to the minor variations of temperature. End organs for the transmission of these sensations are also present in the viscera, in which case it would seem that functionally these fibers exist for the purpose of protection. It is interesting to note that much specificity exists in the pain sensation of the viscera. The handling or cutting of an internal viscus may produce no pain, but an irritative substance affecting the interior, such as a gall or renal stone, causes excessive pain. Thus it may be seen that such sensations answer a demand for function—that of protection.

The second group, the epicritic sensations, include pain and temperature, but these sensations are adjusted to the less intense stimuli. The temperature reactions, heat and cold, are adjusted to the minor variations (from 26° C. to 38° C.) and are sensitive to very light pressure stimuli, giving the individual the power of tactile discrimination. It is believed that separate fibers exist for the mediation of each of these different kinds of sensations. End organs of these sensations are located only in skin surfaces.

In addition to these sensations a group of deep or subcutaneous sensations of pressure, pain, and position (muscular sense) exist.

**Distribution of Cutaneous Sensations.**—The specific end organs or cutaneous receptors of the sensations are located irregularly over the skin surface. Each one is specific in that it is capable of reacting to only certain kinds of stimuli. There are, for example, cold areas, which when touched by a pointed instrument transmit only sensations of cold, and the same is true for the other sensations, such as warmth, pain, and pressure. Sensations normally, therefore, are transmitted by substances

affecting these different sensory areas, and thus the individual gains a knowledge of the nature of his environment.

**The Deep Sensibilities.**—It is now well known that specific afferent units exist for the transmission of sensations from the deeper structures in the body, such as the muscles and joints. In the muscles certain special end organs, the "muscle spindles," and in the tendons the organs of Golgi exist for the reception of specific sensations, which are transmitted through afferent fibers by way of the posterior roots of the cord to the central nervous system. Sherrington believes that about one-fourth of the fibers in the nerve trunks are afferent in function and that most of such fibers are supplied to the afferent receptors in the muscles to the muscle spindles. These afferent fibers are functional in that they reflexly help to maintain muscle tone, assist in co-ordination of muscular contraction of single muscles and groups of muscles, and are also active in maintaining equilibrium. This explains how involvement of the posterior horn and the afferent column may cause ataxia. Afferent fibers carrying these sensations to the brain terminate in the cerebellum and the parietal lobe of the cerebrum. The areas receiving these sensations (posterior central convolutions) are probably associated with the motor areas by connecting fibers forming a complex cerebral reflex arc.

**The Sense of Thirst.**—Sensations of thirst are projected from the region of the pharynx, and it would seem that there must be some kind of specific afferent fibers extending from this region which are involved in the transmission of these sensations. The mechanism of the regulation of the quantity of water in the body has been discussed elsewhere (see chapter on Excretion), and the mechanism of regulating the sense of thirst is not known to have any definite connection with the organs of elimination. It seems that the specific fibers involved in the sensation of thirst react in such a way as to produce conscious sensations of a demand for water when the elimination is excessive or when the body water content goes below a certain level. It seems, also, that the pharyngeal mucous membrane or possibly certain afferent end organs located in this membrane are responsible for the projection of

these sensations, and the glosso-pharyngeal nerve is probably the afferent conducting pathway. As evidence of this it is interesting to note that dry or salty foods, dust, etc., are known to excite a sensation of thirst when allowed to come in contact with these membranes. It may also be noted that in the infectious diseases, in which the pharyngeal membrane is involved, there is often an excessive thirst.

**Sensation of Hunger.**—Like the sensation of thirst, hunger is also to be classed as one of the internal or common sensations. The sense of hunger or appetite is a normal bodily condition occurring at regular intervals and at certain lengths of time after meals. Like the sensation of thirst, sensations of hunger seem to be projected to a certain structure, the stomach, but whether a special kind of mucous membrane or end organ exists for the projection of these sensations is not known. It is thought by some authorities that this specific sensation is only a modified type of muscle sensation projected from the stomach. Because of the fact that decerebrated animals show signs of hunger when they are deprived of food, it is reasonable to suppose that these sensations are general and not referred to any specific cortical area. The sense of hunger can usually be relieved by the taking of an excessive quantity of water into the stomach, which fact again would indicate that this sensation is general rather than specific, and that the sensation is caused by some condition of the stomach wall. It is well known that muscular exercise, low temperature, etc., cause an increase in appetite and it would seem from this that probably some chemical changes in the tissues, such as the oxidative changes, might constitute in some way a cause for the afferent stimulation of the hunger sense, but we have no positive evidence that such is the case.

## CHAPTER XXXIX.

### PHYSIOLOGY OF THE EAR.

The reader is expected to make frequent reference to texts on anatomy, as the structure of the organs considered will be only very briefly given here. (See FIG. 37.)

**Structure and Function of the External Ear.**—The outer part, the pinna or lobe of the ear, probably has no function in the human, since it is not structurally arranged so that it could be of any particular value in the collection or transmission of sound waves. The concha is the cone-shaped opening extending from the pinna to the meatus, and functions in the conduction of sound waves from the exterior into the meatus. The external auditory meatus is an irregularly shaped tube about twenty-five millimeters in length and extending from the concha to the ear-drum. Its chief function is that of conduction of sound waves. The tympanic membrane, which separates the external from the middle ear, is about one millimeter in thickness and consists of the following layers: 1. The external layer is a continuation of the skin, which lines the meatus, and its functions are protection and that of preventing after-vibrations; 2. The middle layer consists of connective tissue and forms the supportive tissue of this membrane; 3. The inner layer is a mucous membrane.

**Structure and Function of the Middle Ear.**—The ear bones are three in number, viz., the malleus, which is in relation with the ear drum and weighs about 20 mgs.; the incus is the second bone of the series and weighs about 25 mgs.; the stapes is the last bone of the series and lies in relation with the fenestra ovalis. These bones are held in position by ligaments and small muscles, and their function is that of conducting the vibrations set up in the ear drum to the fenestra ovalis, where they are in turn trans-



mitted by way of the endolymph to the middle ear. In case of diseased conditions affecting these bones impairment of the structural relations or ankylosis may occur, which impairs hearing.

The Eustachian tube connects the tympanic cavity with the pharynx. Its chief function is that of equalizing the pressure in the cavity and upon the ear-drum. The pharyngeal end of this

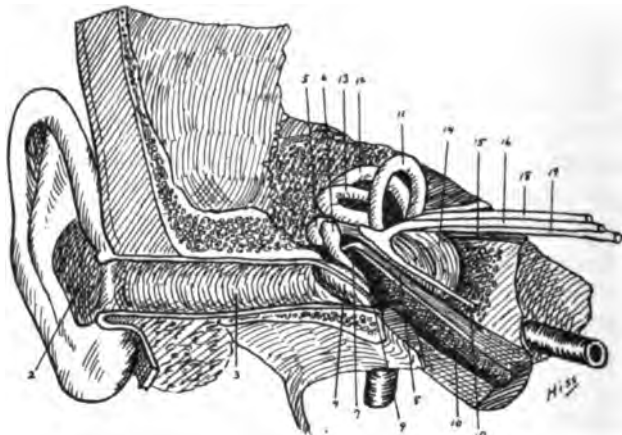

FIG. 37.—THE EAR. 1, Pinna of the auricle; 2, concha; 3, external auditory meatus; 4, ear drum; 5, incus; 6, malleus; 7, malleus; 8, tensor tympani; 9, tympanic cavity; 10, Eustachian tube; 11, superior semicircular canal; 12, semicircular canal posterior; 13, semicircular canal external; 14, cochlea; 15, internal auditory canal; 16, seventh cranial nerve; 17, great petrosal nerve; 18, vestibular branch of the eighth nerve; 19, cochlear branch of the eighth nerve. (Brubaker, after Sappey.)

tube is normally closed, thus preventing the passage of foreign substances into the middle ear. The valve-like opening of the pharyngeal end is regulated by the varying air pressures in the pharynx. From the result of inflammatory conditions it is often permanently closed, thus limiting the equalization of pressure and limiting the power of hearing.

**Transmission of Auditory Sensations.**—Auditory sensations are received upon the tympanic membrane by vibrations in the air and are transmitted to the ear bones, the malleus, incus, and stapes, in regular order and from here to the fenestra ovalis, as explained above.

**The Cochlea.**—The cochlea consists of a spiral, tube-like structure, extending from the membranous opening, the fenestra ovalis, and back to a similar structure, the fenestra rotunda. This structure consists of two parts, the bony and membranous portions, which contain a lymph-like fluid, the perilymph. The vibrations transmitted by the stapes to the fenestra ovalis are carried by way of vibrations in this fluid to the end organs and excessive pressure is prevented by the fenestra rotunda acting as a safety-valve, thus equalizing the pressure in the endolymph. The end organs of the sense of hearing consist of modified epithelial



FIG. 38.—THE BONY COCHLEA. 1, Ampulla of the superior semicircular canal; 2, ampulla of horizontal canal; 3, point of union of superior and posterior semicircular canals; 4, ampulla of posterior semicircular canal; 5, fenestra rotunda; 6, fenestra ovale; 7, cochlea. (After Brubaker.)

cells lying in the cochlea. The nerve cells of the cochlear branch of the eighth nerve lying in the central pillar of the cochlea have their dendrites extending to the organs of Corti, thus forming the receptive end organ of hearing. These end organs are distributed over an area of about five square centimeters. The organs of Corti are supported from the basilar membrane by

specially modified cells known as Deiters' cells. The axones of the nerve cells supplying the organs of Corti extend brainward by way of the acoustic division of the eighth cranial nerve.

**The Theory of Hearing.**—The most probable of the theories advanced for explaining the mechanism of hearing is as follows: The vibratory waves produced in the endolymph stimulate the hair cells, thus producing the reaction which excites the receptor to the transmission of the stimulus. The organs of Corti are about 16,500 in number, and it is generally supposed that these different cells have the power of reacting to vibrations of different pitch, thus differentiating between the different sounds transmitted to the ear. It is known, however, that the human individual is capable of distinguishing a great many more sounds than this

number of receptors could transmit if they are specific for sound waves of different pitch, and it has therefore been explained that the basal membrane may itself react to the different sound waves. The lowest number of vibrations which can be heard by the human ear is about thirty per second and the highest is about forty thousand per second.

**The Course of Auditory Sensations.** — The sound waves received by the concha and transmitted to the tympanic membrane by way of the external auditory meatus set up vibrations in the ear-drum, which in turn sets up vibrations in the ossicles and these transmit their vibrations to the fenestra ovalis. From here the vibration is carried from the labyrinth through the scala vestibuli and from here to Deiters' nuclei and the organs of Corti in the cochlea. They are here received by the cochlear division of the eighth nerve and transmitted to the auditory centers in the medulla. They next pass to the corpus trapezoides of the opposite side and from here go by way of the tegmentum to the inferior quadrigeminal body and the internal geniculate body. From the internal geniculate body impulses are carried by fibers of the internal capsule by way of the auditory radiations to the fissure of Sylvius of the superior temporal lobe.

**Semicircular Canals.**—These structures consist of two parts, a membranous portion and a bony portion, with perilymph between. They are three in number and lie in three planes, each at right angles with the other. The ampulla, which is a swelling on each end near the utricle, contains the sense organs, the crista acustica, which contain hair cells about twenty-five micra in length and which are connected with fibers of the vestibular branch of the eighth nerve. The functions of these structures, as was first discovered by Flourens and since demonstrated by other research workers, are chiefly the control of co-ordination and muscular locomotion. The functions of these structures were discovered by experimentally injuring or destroying one or more of these canals in normal animals and observing the symptoms which followed. From these studies it has been learned first, that these canals are in some way associated with definite movements of the head, eyes,

and body; second, body co-ordination; third, the muscles of locomotion, and there is some reason to believe that each canal is specific in that it has to do with the co-ordinated movements of certain groups of muscles. The effects of section or injury to the semicircular canals are very similar to that of extirpation of the cerebellum. Recovery usually results from injury to the semicircular canals from one month to two years.

**The Utricle and Sacculc.**—These structures contain sensory hair cells, which are probably stimulated by small calcareous deposits known as otoliths. It may be that these structures are stimulated by sound waves in the perilymph and in this way function to some extent in hearing. Another theory is that they are concerned with regulating the co-ordination of the position of the muscles of the head. There is nothing positively known concerning their functions.

## CHAPTER XL.

### THE SENSES OF SMELL AND TASTE.

**End Organs of Smell.**—These consist of modified epithelial-like cells, which are located in the upper part of the nose and on the turbinate bones. Each end organ consists of a small tuft of six or eight hair cells. These end organs are distributed over an area of about ten square centimeters. Nerve fibers extend from them through the cribriform plate of the ethmoid bone and terminate in the olfactory bulb.

**Mechanism of the Sense of Smell.**—Odors penetrating the upper part of the nose during inspiration, or vapors present in the posterior nares, affect the end organs. Because odors in the posterior nares may affect these end organs, the sense of smell is often confused with the sense of taste. Stimulus affecting them must be in the form of gas.

**Conduction of Olfactory Sensation.**—The stimulus is carried from the end organ to the olfactory bulb and from the olfactory bulb by way of the olfactory tract to the olfactory lobes of the same and opposite side. From the olfactory lobes the stimulus goes to the cortex by different pathways, reaching the uncinate gyrus of the hippocampal lobe, the nucleus habenularum, the gyrus subcallosum, the uncus, and the corpus mammillare. It is because of this wide distribution and the complicated association of the centers of the sense of smell that olfactory memories and differentiations are made possible.

**Properties of Olfactory Sensation.**—The primitive function of the sense of smell was that of enabling the animal to distinguish foods and to aid in protection, etc. In certain lower animals the olfactory sensations are much more highly developed than in the human, because those animals depend upon this sense

to a much greater extent than do human individuals. A great many different kinds of odors are distinguishable, but there are no fundamental odors known to exist; i. e., the end organs do not have the property of selective activity, as is the case in the sense of taste. The olfactory apparatus is subject to fatigue when certain odors are smelled continuously for long periods of time. As an example of this it is interesting to note that when one remains in an unventilated room for some time he becomes unconscious of the foul odor, but if he goes into the open air and then returns the foul odor is readily distinguishable. The same condition occurs if one smells any odoriferous substance for a time. It is believed that this phenomenon is due to an actual fatigue of the olfactory apparatus, but whether it is the end organs or the conducting fibers themselves that become fatigued is not known.

**Sensitiveness of the Sense of Smell.**—It is interesting to note that the sense of smell is extremely delicate. The dog, for example, can follow a "cold trail" of another animal which has passed that way many hours, or even days, before. The human is able to distinguish certain odors in very dilute solutions. It is possible to detect camphor in a dilution of 1 to 400,000, and certain musks may be distinguished in much greater dilutions.

Olfactory sensations are often confused with the sense of taste and certain common sensations projected from the nose, mouth, and pharynx. This is because the individual is accustomed to comparing the odor and taste of many substances used as foods and because the volatile liquids, when taken into the mouth, pass by the posterior nares and affect the sense of smell at the same time that they affect the sense of taste.

**End Organs of the Sense of Taste.**—The tongue is the most sensitive part, probably because the most specific of the end organs are located on this structure. End organs of the sense of taste—the taste buds—are located on the tongue, the circumvallate and fungiform papillæ. (See FIG. 39.) Other end organs of the sense of taste are located on the fauces, the palate, the epiglottis, and on the vocal cords. They are distributed over an area of about forty square centimeters.

**Fundamental Taste Sensations.**—Four specific taste sensations are known to exist: sweet, which is normally present on the tip of the tongue, and bitter on the back part of the tongue. Two other fundamental sensations, salty and acid, are known to exist, but they have not been definitely located. There may be other specific taste sensations, but if such exist their location is not known. Others which seem to be possible of recognition may be a result of complications of these four or they may be a result

of the transmission of the sensations of taste, sensations of smell, and common sensations.

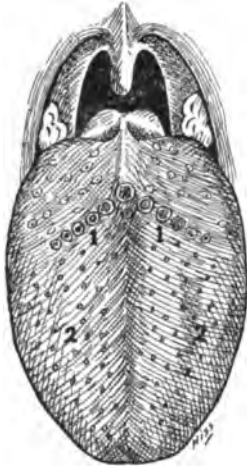

FIG. 39.—THE TONGUE. 1, Circumvallate papillae; 2, fungiform papillae. (After Brubaker.)

**Nerve Supply.**—The anterior two-thirds of the tongue receives sensory fibers from the lingual nerve and fibers of special sensation from the chorda tympani branch of the seventh nerve, which goes to the tongue by way of the lingual nerve. There has been some question as to whether fibers of the fifth nerve supply the tongue with specific sensations of taste. It has been noted after surgical operations, in which the ganglion of the fifth nerve has been removed, that the sense of taste is destroyed, which by some is considered evidence that this nerve

supplies the tongue with special sensory fibers; but insufficient evidence has been shown to prove this statement, and it seems safe to conclude that the seventh is the only nerve which gives fibers carrying specific sensation to the anterior two-thirds of the tongue. The posterior one-third of the tongue is supplied by the ninth cranial nerve.

**Properties of Taste Sensations.**—Many taste sensations are confused with the sense of smell, because, as mentioned above, these two senses are very closely associated and because many substances taken into the mouth are volatile and therefore excite the end organs of the sense of smell. Many so-called tastes are

really odors and many so-called odors are really tastes. Chloroform, for example, has the power of stimulating the taste of sweet and is, therefore, often said to smell sweet. In order that substances may excite the end organs of the sense of taste they must be in the form of fluids, either liquids or gases.

It is not positively known how the specificity in taste sensations is effected, but it is generally considered that it is due to the nature of the end organ receiving the sensation. It may be assumed that certain of the end organs of the sense of taste are particularly adapted to the reception of only certain kinds of stimuli, and in this way the fundamental taste sensations are distinguishable. It is possible, however, that there may be some particular adaptation of the nerve fibers or the receiving centers, which also assists in distinguishing and differentiating taste sensations.



## CHAPTER XLI.

### PHYSIOLOGY OF THE EYE.

The reader is urged to make frequent references to texts on anatomy. In fact it is advised that students be given a thorough review of the anatomy of each structure before considering the physiology.

**Functions of the Sclerotic Coat.**—The sclerotic is the outer coat of the eyeball and consists of the sclera proper, which

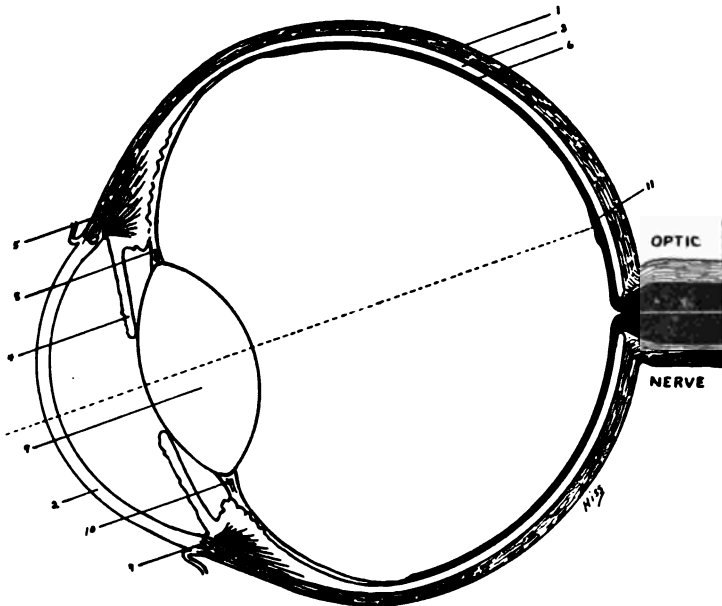

FIG. 40.—This figure shows a horizontal section of the eyeball. 1, The sclerotic coat; 2, the cornea; 3, the choroid coat; 4, the iris; 5, the ciliary body; 6, the retina; 7, the crystalline lens; 8, suspensory ligament of the lens; 9, the canal of Schlemm; 10, the canal of Petit; 11, the optic nerve. (After Deaver.)

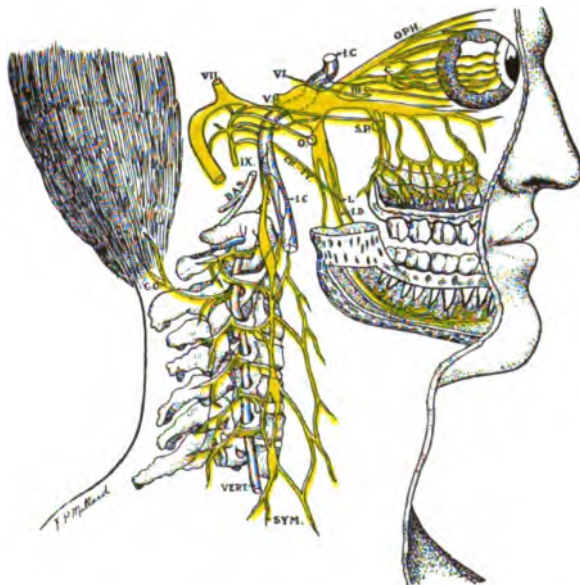

PLATE XXV.—I. D., inferior dental to lower teeth. Partial dislocations of the lower jaw may irritate the fifth cranial nerve through its branch (I. D.) and produce headaches in the temples, facial neuralgia, neuritis, etc; Oph., ophthalmic division of trifacial nerve; C., ciliary ganglion to eye; O., otic ganglion on inferior maxillary branch of trifacial nerve; L., lingual nerve joined by (ch. ty.) chorda tympani nerve; G. O., great occipital nerve to back of scalp; S. P., spheno-palatine ganglion connecting with V, VII, and IX nerves, also sympathetic chain (Sym.); Vert., vertebral artery joined by its fellow at top of atlas to form the basilar which help to supply the brain with blood; III, motor oculi cranial nerve; V, trifacial cranial nerve; VI, abducent cranial nerve; VII, facial cranial nerve; IX, glosso-pharyngeal cranial nerve.



covers the greater portion of the eyeball. Its function is chiefly that of protection. The cornea is the modified anterior portion of the sclera and is joined to the sclera by a direct continuity of tissue. The cornea is transparent, which property allows the free transmission of light. It is supplied with lymph and nerve fibers, but has no blood vessels. The functions of the cornea are protection and transparency to light, thus allowing the admission of light to the aqueous humor. There are five layers of the cornea from in front backwards, viz., the anterior epithelial, the elastic laminæ, the substantia propria, whose function is that of furnishing lymph for nourishment of the other parts of the eye. The fourth, the posterior elastic layer, is commonly known as the membrane of Descemet. From the periphery of this layer prolongations of fibers extend, forming the pectinate ligament. A circular opening, the canal of Schlemm, extends around the base of the membrane of Descemet. This canal is connected to the lymph of the anterior chamber of the eye by a number of openings known as the spaces of Fontana, thus forming a mechanism for the supply of lymph to the cornea. (See Fig. 40.)

**Functions of the Choroid Coat.**—The choroid is the vascular coat, whose chief function is to supply nourishment to the retina. The iris is the anterior continuation of the choroid coat. (See anatomy.) Other functions of the choroid are the regulation and maintenance of intra-ocular pressure, and the pigment of the choroid performs a dioptric function, that of absorption of the stray rays of light.

**Functions of the Retina.**—The student is referred to texts on anatomy and histology for the structure of the retina. The anterior termination of the retina on the inner surface of the choroid is the ora serrata. The deep pigmentary layer prevents the refraction and reflection of light rays. In the posterior part of the eye the maculalutea (yellow spot), about two millimeters in diameter, contains a highly sensitive portion in its central part, the fovea centralis. The blind spot is that portion of the retina where the optic nerve enters, and there are therefore no end organs specifically sensitive to light in this area. The end

organs in the retina react to the effects of light and the impulses are transmitted by way of the optic nerve.

**The Ciliary Body.**—This structure consists of the orbicularis ciliaris, the ciliary process, and the ciliary muscles. (See anatomy and FIGS. 40 and 41.)

The ciliary muscles consist of two groups of fibers. The radial fibers originate from the cornea-scleral junction and the pectinate ligament. These fibers are inserted into the choroid, and their contraction draws the choroid forward and reduces the tension on the suspensory ligament of the lens. The function of the circular fibers (the muscle of Muller) is not known.

**The Iris.**—The iris is an anterior process of the choroid, and consists of the following layers: 1. The anterior layer; 2. The stroma or supportive tissue containing the vessels of the iris and the pigment, which prevents the transmission of light through other parts than the central opening of the iris, the pupil; 3. The muscles of the iris consist of two layers, the radial fibers the contraction of which causes the retraction of the structures of the iris and dilation of the pupil, and the circular fibers, contraction of which causes just the opposite change—the constriction of the pupil.

**Nerve Control of the Iris.**—The circular fibers of the iris are supplied by the short ciliary branch of the third cervical nerve. Stimulation of these fibers causes contraction of the circular fibers and constriction of the pupil. The nucleus of the third nerve is functionally connected with the anterior quadrigeminal body, one of the central terminations of the optic nerve, and it is by this mechanism that excessive stimulation of the retina by light waves causes reflexly a constriction of the pupil and in this way the amount of light admitted to the retina is decreased. These nerve connections thus form an automatic adjustable mechanism for regulating the amount of light transmitted to the retina.

The radial fibers of the iris receive their nerve supply from the cervical autonemics. The pre-ganglionic fibers arise from cell bodies lying in the antero-lateral portion of the upper dorsal

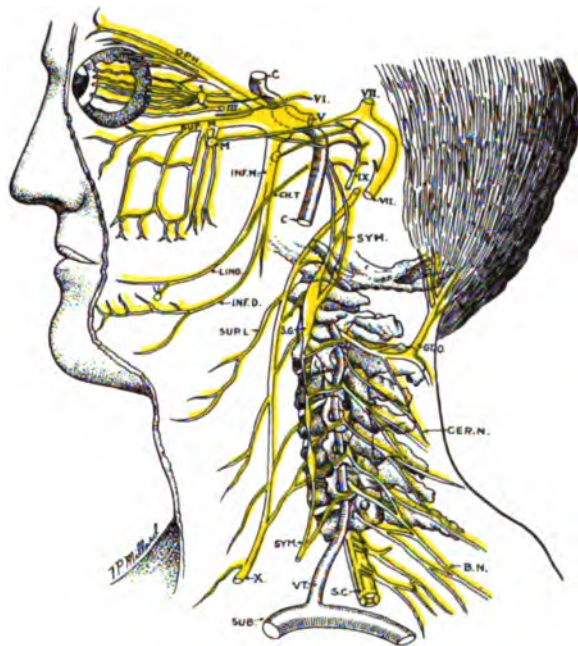

PLATE XXVI.—G. T. O., great occipital nerve, supplying the back part of the scalp muscles and producing severe headaches when interfered with. Tight muscles in the back of the neck, or a twist between the atlas and axis may cause a disturbance of the 2nd cervical spinal nerve and result in suboccipital headaches. S. C., spinal cord; O. P. H., ophthalmic division of trigeminus. This branch sends nerve twigs up over the eye and therefore frontal headaches are often the result of lesions involving this nerve. Note the close connection existing between this nerve and the sympathetic chain (Sym.), also the spinal nerves (Cer. N.) C, ciliary ganglion; Sup.M., superior maxillary division of trigeminus; Inf. M., inferior maxillary division of trigeminus; M., Meckel's ganglion; Ch. T., chorda tympani nerve; Ling., lingual nerve; Inf. D., inferior dental branch; Sup. L., superior laryngeal branch of the pneumogastric; Sym., Sym., sympathetic nervous chain communicating with the spinal cervical nerves, (Cer. N.); B. N., brachial plexus of spinal nerves which go down the arm to fingers; S. G., superior cervical ganglion; III, motor oculi cranial nerve; V, trifacial cranial nerve; VI, abductor cranial nerve; VII, facial cranial nerve; IX, glosso-pharyngeal cranial nerve; X, X, pneumogastric cranial nerve; C., C., internal carotid artery; Vt., vertebral artery; Sub., subclavian artery.



segments of the spinal cord. They pass out to terminate about cell bodies in the lateral chain ganglion and pass upward to be distributed by way of the long ciliary branch of the ophthalmic division of the fifth cervical nerve. Stimulation of these fibers or stimulation of the cervical autonomies causes dilation of the pupil. A functional connection exists between the nucleus of the third nerve and these cell bodies of the pre-ganglionic fibers of this system, thus associating the functions of the dilator and constrictor fibers of the iris.

Stimulation of the sensory spinal or cervical nerves reflexly influences the dilator fibers of the pupil by causing a stimulation of the cells in the cord from which the pre-ganglionic fibers of this system arise. It is interesting to note that the stimulation of the spinal autonomic fibers serves as a preparation of the animal for emergencies by causing vaso-constriction, increased heart action, and pupillary dilation. In this way any extreme external stimulation, whether reflexly affecting the central nervous system or causing mental excitation, causes reflex stimulation of the spinal autonomic system, thus quickly adjusting the animal's physical reactions to meet emergencies. By the law of the demand of function this physiological adjustment has been developed. The fact that one system of fibers supplying the iris arises from the upper dorsal is of much osteopathic significance, because it is not uncommon to find in clinical practice that bony lesions of this region are associated with perverted functions of the eye.

**Conditions Causing Constriction of the Pupil.—1.**

Stimulation of the optic nerve causes constriction of the pupil by reflexly stimulating the third nerve, which supplies the circular fibers of the pupil; 2. Stimulation of the third nerve directly; 3. Section of the fifth (ophthalmic division) causes constriction of the pupil, because it cuts off the tone to the radial fibers, thus allowing the constrictors full play; 4. Section, paralysis, or over-stimulation of the cervical autonomies may cause constriction of the pupil in the same way as described above. It is not uncommon that constricted pupils or pupils which react abnormally to light result from lesions of the cervical or upper dorsal regions,



because of some interference with the functional activities of this nerve path; 5. Excess of light on the retina causes constriction of the pupil by reflex stimulation of the third nerve; 6. By accommodation for near objects the pupil is constricted voluntarily; 7. Drugs known as myotics such as eserine, cause constriction of the pupil; 8. Anesthesia causes constriction of the pupil at first, but, if the anesthetic is continued, the opposite reaction results.

**Conditions Causing Dilation of the Pupil.**—1. Section, lesion, atrophy, or paralysis of the optic nerve cause dilation of the pupils, because by such lesions the reflex tone is cut off from the third nerve, which supplies the circular fibers, thus allowing the radial fibers to act excessively; 2. Any lesion interfering with the normal functions of the third nerve, thus reducing the tone of the circular muscles, results in dilation of the pupil; 3. Stimulation of the fifth cranial nerve or the cervical autonomics causes pupillo-dilation by direct stimulation of the radial fibers; 4. Stimulation of any sensory spinal or cranial nerve may reflexly increase the tone of the cervical autonomics and cause pupillo-dilation; 5. Anything which increases the tone of the spinal autonomics, such as psychic effects, fright, anger, sexual excitement etc.; 6. Mydriatics, drugs which cause dilation of the pupil by paralyzing the third nerve. Such drugs as cocaine, eucaine, atropine, hyoscyamine, etc. cause these effects; 7. Dyspnea, asphyxia, and other forms of abnormal respiration cause dilation of the pupil; 8. Anesthetics, when administered excessively, cause dilation of the pupil.

**The Physics of the Eye.**—Light waves constitute the normal stimulus of the eye. It would be well for the student to review the physics of light in some good text on the subject, as space would not permit such a review here. Perception of light results from a stimulatory effect of light waves on the cellular elements of the retina. The transmission of these impulses and their effects upon the brain centers results in the production of the conscious effects.

The eye may be compared to the camera in many different ways. The opening in the iris, the pupil, corresponds to the

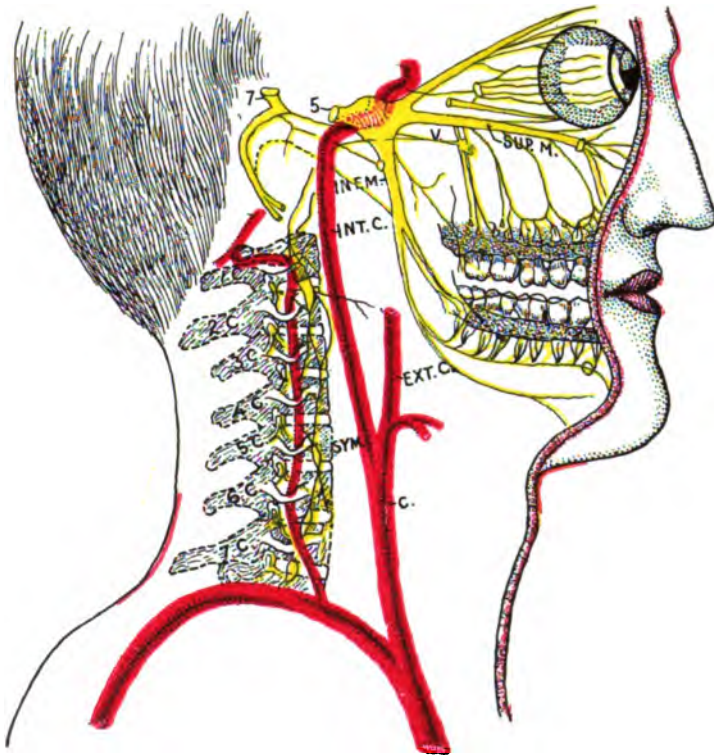

PLATE XXVII.—Normal cervical vertebrae showing spinal nerve connection with nerves to teeth and eye. 1 C, 2 C, 3 C, 4 C, 5 C, 6 C, 7 C, cervical vertebrae with the spinal nerves emanating from the spinal cord through the foramina, and connecting with the sympathetic chain (Sy. M.) in front of the vertebrae. This sympathetic chain connects with the fifth cranial nerve which sends branches to the teeth. C, common carotid; Ext. C., external carotid; Int. C., internal carotid; 5, trigeminus nerve; 7, facial nerve; Inf. M., inferior maxillary division of the trifacial nerve which supplies the lower teeth; Sup. M., superior maxillary division of the same nerve, which supplies the upper teeth. Notice the 5th and 7th nerves connecting through the Vidian nerve. (V.)



diaphragm of the camera, and just as the opening in the diaphragm of the camera is reduced when accurate definition is wanted, the size of the pupil is reduced when one wishes to see certain objects more distinctly. By this method a fewer number of rays of light are allowed to enter the eye, but these pass through the central part of the lens and there is no diffusion. Therefore the formation of a more distinct image on the retina results. When the pupil is widely dilated waves of light from a great many more different angles may enter the eye and one is able to take in his immediate surroundings more quickly, but nothing is distinctly seen. In this respect the eye is like the universal lens camera.

**Refractive Media of the Eye.**—The purposes of the refractive media of the eye are transmission of light and the focusing

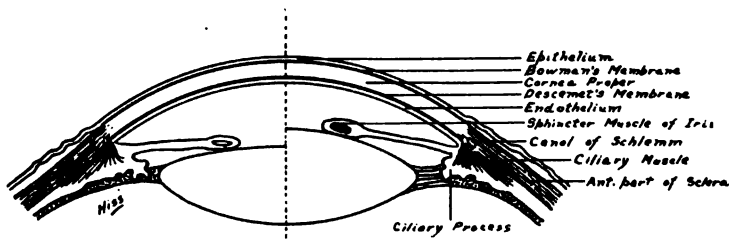

FIG. 41.—The right half shows the lens bulging forward in accommodation. The left half shows the lens in normal position. (After Brubaker.)

of the rays in such a way as to avoid diffusion. The refractive media of the eye are the cornea, the aqueous humor, the crystalline lens, and the vitreous humor. Of these the crystalline lens is by far the most important. It is an elastic, highly transparent, double convex lens, supported in a capsule which is attached to the choroid coat. When the tension on the capsule is reduced the anterior portion of the lens bulges forward, thus increasing the convexity of the lens, which increases its refractive power. If for any reason the lens is imperfect and all rays of light are not properly focused upon the retina at any one point imperfect vision follows, the condition being known as spherical aberration. The outer margin of the lens is less convex than the mid-portion,

and when the pupil is widely open rays of light may pass through this part, in which they are imperfectly refracted in proportion to the other rays. The result is impairment of vision and is known as chromatic aberration. The difficulty may be overcome by constricting the pupil. The pigment of the retina effects the absorption of the stray rays of light and thus prevents diffusion. In this way minor disturbances in vision resulting from errors of the lens, if not too great, are partly prevented.

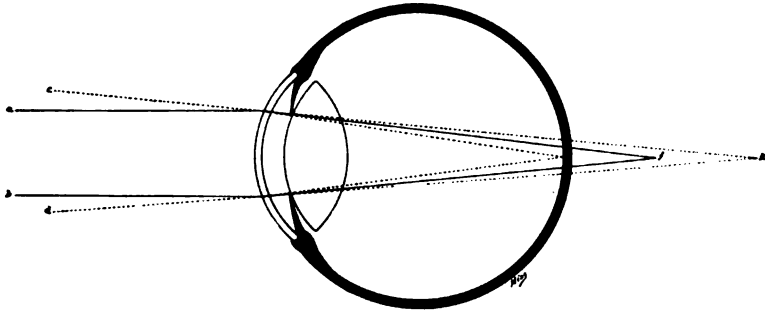

FIG. 42.—Showing the condition occurring in a hypermetropic eye. The parallel rays of light are seen to focus at a point behind the retina. (After Brubaker.)

**Conditions Causing Imperfect Refraction.**—Normal refraction occurring in the normal eye is known as emmetropia. Hypermetropia is a condition of abnormal refraction, in which the rays of light come to a focus behind the retina. The condi-

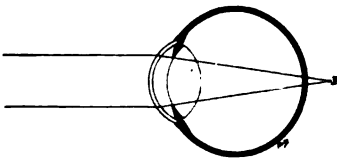

FIG. 43.—This figure shows the rays of light coming to a focus behind the retina because the eyeball is too short. (Brubaker.)

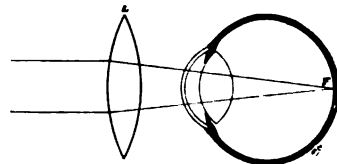

FIG. 44.—This figure shows the correction of the condition seen in FIG. 43 by the use of a double convex lens. (Brubaker.)

tion may be due to the eyeball being too short or the lens being insufficiently convex. Myopia is a condition of abnormal refraction, in which the rays of light come to a focus in front of the

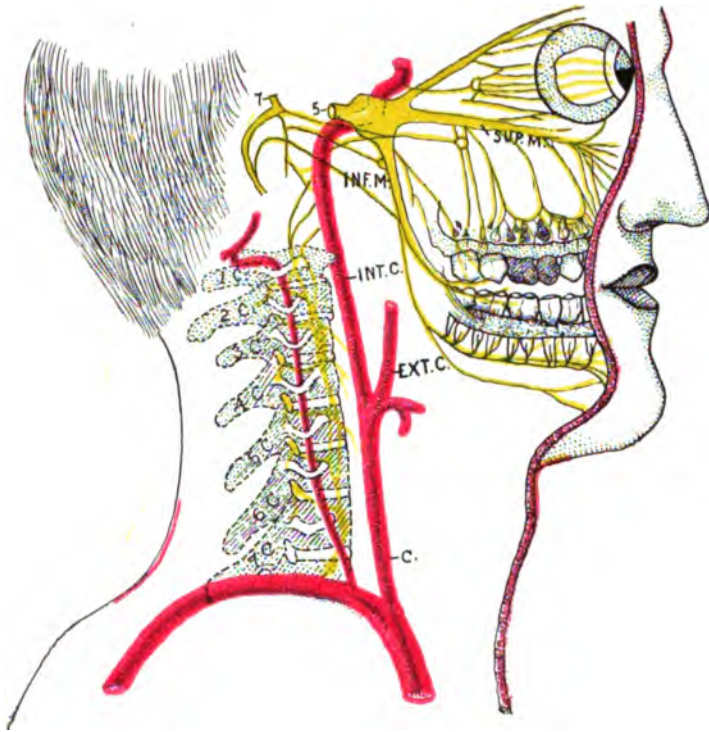

PLATE XXVIII.—This plate shows the same nerves and blood vessels as Plate XXVII, but a special lesion is shown. The second cervical vertebra, (2 C) or axis, is rotated and irritating the spinal nerves, and reflexly, disturbing the terminal nerves to the teeth through the trifacial nerve, which might produce neuralgic symptoms. Deadening the same, or killing the nerve in the teeth will not lessen the irritation to that nerve, which is constantly produced by the lesion existing at the axis. Two upper teeth are shown with the nerves "killed."

C., common carotid; Ex. C., external carotid; Int. C., internal carotid; 5, trigeminal nerve; 7, facial nerve; Inf. M., inferior maxillary division of the trifacial nerve, which supplies the lower teeth; Sup. M., superior maxillary division of the same nerve, which supplies the upper teeth. Notice the 5th and 7th nerves connecting through the Vidian nerve (V.)



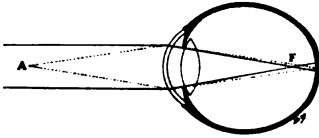

FIG. 45.—This figure shows a condition of myopia. The parallel rays of light are seen to focus in front of the retina because the eye ball is too long. (After Brubaker.)

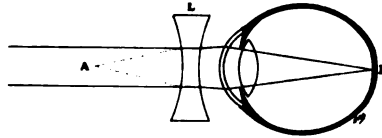

FIG. 46.—This figure shows the same condition as in FIG. 43. Corrected by the use of a double concave lens. (After Brubaker.)

retina. This condition is just the opposite of hypermetropia and is due to the eyeball being too long or to the lens being too convex. Astigmatism is a condition of imperfect refraction caused by certain defects in the lens, so that the light rays in different meridians are not focused at the same point on the retina. This condition may be due to many different causes.

**Mechanism of Accommodation.**—It has been shown above how, when the radial fibers of the ciliary muscle contract, the choroid coat is drawn forward. This reduces the tension on the suspensory ligament and allows the lens to bulge forward, thus increasing the power of refraction. The lens is sufficiently convex in the normal eye to make any special effort of accommodation

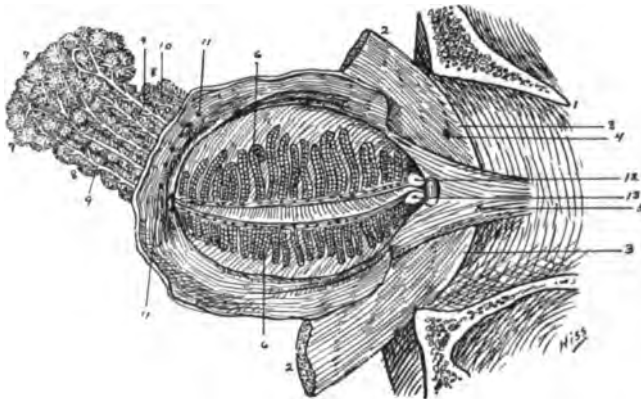

FIG. 47.—THE GLANDS OF THE EYE. 1, Inner wall of orbit; 2, inner portion of the orbicularis palpebrarum muscle; 3, attachment of the muscle to the orbit; 4, foramen for nasal artery; 5, the tensor tarsi muscle; 6, Meibomian glands; 7, lachrymal glands, orbital portion; 8, 9, and 10, palpebral portion of lachrymal glands; 11, openings of ducts of lachrymal glands; 12, and 13 lachrymal puncta. (Brubaker, after Sappey.)



unnecessary except in exceptional cases, when especially accurate perception is necessary.

**Accessory Structures of the Eye.**—The eyelids consist of an outer covering of skin and an inner lining of modified epithelium, the conjunctiva. Between these two layers a semilunar cartilage, known as the tarsus cartilage, is contained, which forms the framework of the upper lids.

The lachrymal apparatus consists of a number of glands located in the upper, outer part of the orbital cavity. These glands are supplied by branches of the fifth nerve and the cervical autonomic. Their secretion, the tears, which consist of water and inorganic salts, is emptied upon the conjunctiva and eyeball for the purpose of lubrication and protection. There are from seven to ten ducts, which open into the upper, outer part of the conjunctiva. The tears are normally drained away by way of the lachrymal puncta into the lachrymal ducts and the nasal ducts.

The Meibomian glands are embedded in the posterior portion of the lids. They secrete a lubricant for the lids. The lashes are hair projections extending from the outer margins of the lids and serve the purpose of protection.

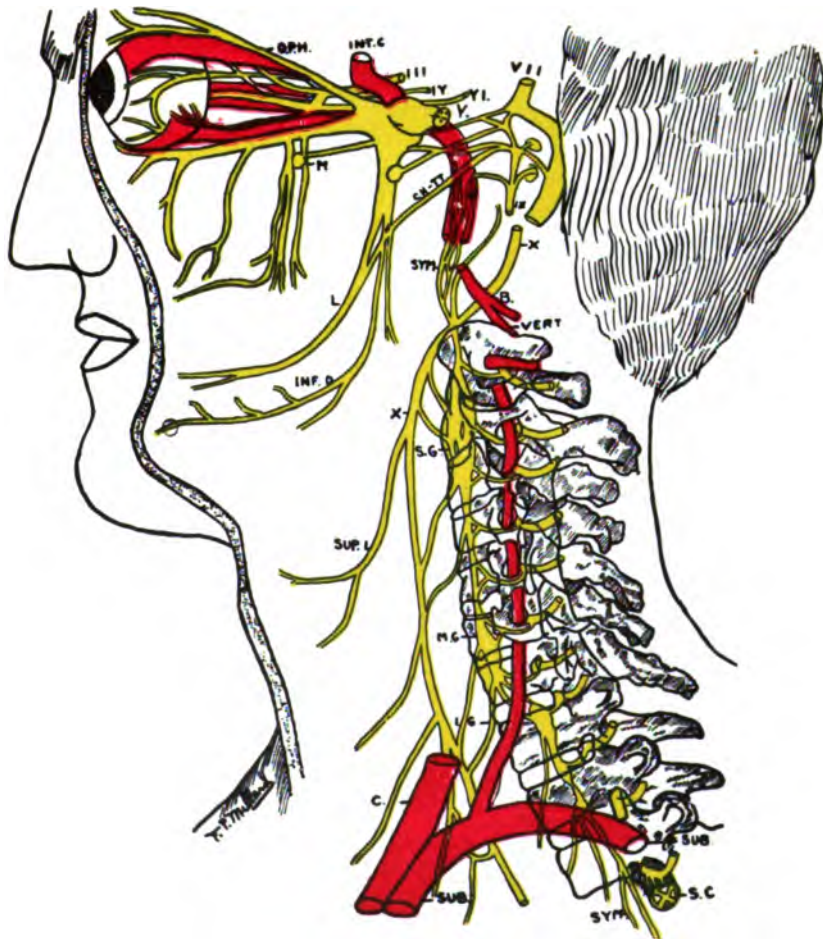

PLATE XXIX.—This plate shows the complete nerve supply to the muscles of the eye, also the nerve connection through the sympathetic with the cervical nerves by way of the rami communicantes.

II, optic nerve; III, motor-oculi; IV, pathetic; V, trifacial; VI, abducent; VII, facial; IX, glosso-pharyngeal; X, pneumogastric; Oph., ophthalmic division of the trifacial; Int. C., internal carotid; M., Meckel's ganglion; Ch. Ty., chorda tympani nerve communicating with the lingual (L); Inf. D., inferior dental; Sup. L., superior laryngeal; S. G., superior cervical ganglion; M. G., middle cervical ganglion; I. G., inferior cervical ganglion; B., basilar artery; Vert., vertebral artery; C. C., common carotid artery; Sub., subclavian artery; Sym., sympathetic chain; S. C., spinal cord.



# SECTION IX

---

RESULTS OF DR. McCONNELL'S  
RESEARCH WORK



## PART II.

### OSTEOPATHIC RESEARCH IN PHYSIOLOGY.

---

#### THE OSTEOPATHIC LESION.

CARL P. McCONNELL, D. O., CHICAGO.

---

#### CHAPTER XLII.

#### STATEMENT OF PROBLEMS.

The practical application of the sciences that comprise the study of osteopathy is undoubtedly the most difficult problem that confronts the student. He is not only brought face to face with the correlation and unification of several allied branches of study, but the application, the art, of the dependent therapeutics is no small matter, for his success or ability is measured by his being able to apply his knowledge. And where the really severe test comes is at the bedside, for here typical presentations and classical descriptions are by far in the minority. Both logically and practically familiarity with the anatomical structure is the first requisite. Without thorough knowledge of every part of the field of possible operation no one for a moment would think of entrusting himself to the surgeon who has not all of the facts at his "finger ends." The same situation is just as true with the osteopath, for upon his knowledge of the facts will the serious question of life or death often depend. In fact it is a *reductio ad absurdum* to even think that one can know much about any

mechanism who is not perfectly familiar with the component parts and their relationship. Although with the human mechanism the analogy can be carried too far, for here we are dealing with a vital mechanism, nevertheless a most thorough workable knowledge is absolutely demanded.

Following an understanding of the anatomical parts, the next requisite is applied physiology. Here in reality is the pivot of a triplex. First, a familiarity of the make-up of the organism; second, the practical application of the innumerable functions, the physiology, not only separately but in their inter-relationship; third, the art, the technique, as is implied in all that adjustment means both mechanically and skillfully. But as we have just said, the physiological, the functional requisite is the central criterion. The functioning of a mechanism is the final test, for without this all other experience or proof is useless.

Variation of the human organism is the one great stumbling block of the tyro. This includes a large field. And so, frequently text-book information may be a source of confusion for the student unless he has early acquired the rare ability of unifying and classifying his reading knowledge and applying it to his practical observations and experience. The most obvious of all the anatomical does not always follow the text descriptions by considerable; variation is frequently rampant here and the law of averages must be consulted. There is the varying quality of tissue dependent upon heredity, nutrition, pathology, age, etc. Position, modification, alteration of tissue and viscus frequently comprise problems of no small moment. Then the mental characteristics involve study of greater or less magnitude. In short, individuality of every human organism is a most vital and persistent question proposed for everyday solution. So it all comes back to the physiologic test, whether the case at issue, no matter what seeming variations it may present, approaches the norm of functional practicality.

At best we can grasp only a slight understanding of the intricate functioning of the body. Certain broad principles give us a working basis upon which we can build a rational superstructure

of therapeutics. First and foremost the body organism is a self-reparative mechanism. No system of treatment can cure or repair a damaged tissue. Nature alone takes care of this. All any one can do is simply to assist her in so far as compatible with mechanical obstructions, hygiene, environment, diet, and surgical cleanliness. This is the limit of finite endeavor. It has nothing to do with the actual reparative process—it simply gives nature a greater opportunity to assert her powers. Conversely great care must be taken not to promulgate meddling activity.

The body organism is in a constant state of flux, of change. There is not, and can not be, a perfect organism. An ideal faultlessness means an imaginary standard of excellence. Such a state can not be so long as there is growth, development, and repair. The potentialities of the germ-plasm and the response to environment preclude such a thing as an absolute perfection. We are part of nature and our response and growth are in accordance with biologic laws. The principles remain the same but there is an ever varying application of its laws. But this is not to be interpreted that the body is not a complete organism. It contains all the forces and resources necessary for growth, repair, and recuperation under the ordinary stress and strain of environment. Naturally there is a limit wherein accidental happenings, destructive pathologic conditions, extraordinary virulence, and marked lowered resistance can not be successfully combated. In other words the material, physical body represents a complete organism, but necessarily a self-limited mechanism in accordance to physical and chemical laws. The life principle is hedged in and restricted in its material expressions compatible with the laws of the physical. Consequently the osteopathic application is based upon an understanding of these laws, and therapeutic technique is nothing more nor less than an appreciation that nature's resources and limitations are supreme. This includes the absolute boundaries of finite ability.

With all of our present-day knowledge we know very little of the actual happenings that take place in the cell. The cell contains all the resources, active and potential, and is, in a sense,



the final arbitrator. It represents the criterion of physical and chemical completeness. Its measurements and restrictions is the ultima Thule. But this statement, however, should be somewhat qualified: The cell is the physical foundation of the body and in its primitive form contains potentially the fundamental properties of an organism, but specialization of structure is attained at the expense of certain attributes. Certain technical methods give us a bare outline of its structural make-up, but as to the dependent processes of molecular changes we know next to nothing. We are in a somewhat similar situation of a being high in the heavens that sees an occasional house of a village amongst the trees below. He knows something of the activities as a unit but realizes that the many intricacies of the different households contain the "vital principle" that in the aggregate characterize the special functions and the individuality of the organ. He may remain in his position until the leaves of the trees have disappeared and his view will be much clearer, but his knowledge of vital functions will not be correspondingly increased.\*

Although the cell is the unit of structural mass and functional expression and contains limited resources of its own, still it is dependent upon the organism as a whole for continued activity. It is the interdependence of all cells and organs that expresses the individuality of an organism. The controlling nervous system, the circulating vascular system with its properties of nutrition and chemical co-ordination correlate and concatenate the organism. All of this intricate and complex structure constitutes the complete being.

The student should ever keep before him that the body is a plastic organism. The variations and adaptations are not only the result of the germ-plasm characteristics, but there is an internal mechanism that responds to environmental conditions. Environmental forces include a wide range of sources, from habits to climatic changes and from dietetic effects to respiratory influence, culture, modes of life, chemical changes, etc. All of these have

---

\* More than seventy years ago Schwann said that the life of the organism is the sum of the lives (chemical and physical changes) of the individual cells.

either a direct or indirect influence upon the body and thus health or ill-health may be the consequence.

Growth and development of the body are very dependent upon exercise. Indeed, without exercise tissue and viscera are unable to fully develop. The body is as dependent upon exercise as it is upon oxygenation and food. The growing child absolutely requires that every muscle be brought into activity in order that not only the physical mechanism as exemplified in muscles and viscera be brought to a state of usefulness, but also in order that the brain itself be fully developed. This is a fundamental requirement.

All of the above necessities are more or less directly influenced and controlled by the nervous system. The afferent and efferent system work together as a physiologic unit. In a sense the afferent impulse is the source of all energy, for without its functioning and the controlling tissue, the nervous system, is unable to function. Plasticity of the body largely rests with the adaptability of the afferent and efferent system. Herein is the avenue of approach to the so-termed vital activities, even to the entrance of external influences that pertain to mental growth. Indeed, the physical and mental are complementary, and both are based upon the same physiologic law. The intricacy and complexity of the interrelated whole is brought into harmony through the medium of this system. This is the key in a broad sense to the importance of the osteopathic lesion as a factor of the health problem.

The osteopathic lesion, as we shall see, rests for its interpretation upon a broad biologic basis. It is fundamentally a blockage to the afferent impulse. And any interference with the afferent integrity means disorder, disease, for thereby growth, development, repair of tissue and vital resistance is impaired. The body being built upon mechanical lines is subject to mal-adjustment whether of bone, muscle, ligament or viscus, and this at once implies interference with the afferent impulse and as a result the concatenated whole is deranged.

The spinal column is of first consideration owing to its relationship to the superimposed segments termed the spinal cord.

This is the significance of the vertebral lesion. However, the afferent impulse may become disturbed elsewhere, as for examples, displacements and adhesions of a viscus, a pelvic derangement or a weak foot. The physiologic fundamentals are the same, although the application mechanically may be different. The therapeutic danger lies in being lost in a maze of details and thereby not keeping the broad physiologic application intact.

Let us outline in this sketch two or three points a little more fully, which, in our opinion, contain the essence of the relationship of the osteopathic lesion to physiology:

(a) The body as a unit. We commonly speak of the body as being a machine. This is true to a large extent, for the laws of mechanics and mathematics are applicable to its structural make-up to a surprising degree. But it is much more than a machine, for what we regard as physical and chemical laws do not comprise all of the constituent laws of physiologic processes. There is the biotic energy which, according to our present understanding of physics and chemistry, is separate and distinct (still dependent), although we are unable to define it.

There is no part of the body that is really autocratic. Hering has well said that "the human body does not receive the impulse of life like a machine from one point, but each single atom of the different organs bears its vitalizing power in itself." We must view the body as a most complex mechanism, wherein every part has a distinct relation to every other part. This inter-relation is controlled by the nervous system. And the afferent impulse is the source of all physiologic activity. Consequently anything that impairs the afferent impulse will more or less profoundly disturb the entire mechanism in part or as a whole, or corresponding to the extent of blockage or degree of irritation.

(b) The relation of the nervous system to the body unit. It should be constantly emphasized that the nervous system is the controlling factor. Whether the process is physical or mental, a very minor tissue growth or repair, a spinal cord reflex, a stimulus to the so-called vital centers of the medulla, or a mental process, the incoming afferent impulses initiate the dependent train of

activities. And every part of the body contributes to a greater or less degree its quota of impulses, thus bringing into definite relationship a concatenated whole.\* The afferent and efferent systems are to a certain extent plastic, which allows conformance to demands of growth and repair as well as requisition of coordinate variations and environmental changes. Thus no center is isolated, but instead it is subject to peripheral sensory impulses. The center does not originate impulses, but is quite dependent upon the incoming stimulus. Exercise, fresh air, diet, environment, and all that constitutes hygiene has a profound effect necessarily upon the body organism. Thus by virtue of this regulating mechanism the body works as a whole, nothing more nor less. There is no automatism, but instead the sensory impulses and the quantity and quality of the blood is the inception of physiologic changes. Hence the significance and the importance of the osteopathic lesion can not be gainsaid. Obstruction of circulation or of nervous impulses strikes at the very fundamentals of health or wholeness.

(c) The osteopathic lesion. This has been defined by Hulett as "any structural perversion which by pressure produces or maintains functional disturbance." We have emphasized the structural make-up, the functional test, the body unit, and the regulating mechanism. By virtue of all of this, biologically an intact unit is absolutely essential to health. Hence the osteopathic concept rests upon the solid basis of physiologic principles.

---

\* "Every vital phenomenon may be regarded as a reaction conditioned by some change in the environment of the animal and adapted to its preservation." "The object of a nervous system is to ensure the co-operation of the whole organism in any reaction to changes in its surroundings." (Starling—"Human Physiology.")

## CHAPTER XLIII.

### EXPERIMENTAL WORK.\*

We have been carrying on a series of experiments for the past nine years to determine the nature of the osteopathic lesion on animals. The work has comprised a study of more than a hundred animals, principally dogs, a few rabbits and guinea pigs. We do not wish to be understood that we consider the work finished in any sense, but instead simply a start in which we believe is an important scientific part of the osteopathic problem. Other workers have for a number of years been engaged in the scientific field on allied phases. Dr. Deason has in his experiments verified certain parts of our findings.

The production of the lesion is a simple but still a very important matter. It cannot be performed successfully in a haphazard manner. Strict attention to the thorough relaxation of tissues about the field of operation and definite application of mechanical principles are demanded. After selecting a healthy animal (preferably a small or medium-sized dog), surgical anesthesia is best; although in our later experiments we would say it is not necessary, for we have been able to accomplish results quite easily without resorting to anesthesia. Relaxation of the area of intended operation is an essential for ease of lesion production. Having determined the character of osteopathic lesion desired—that is, right or left rotation, or hyperextension, or hyperflexion, or combination of these—the second essential is to apply definite mechanical principles. Bringing the fulcrum to bear at just the desired point when the tissues are thoroughly relaxed is as necessary in producing a lesion as in adjusting one. Much strength

---

\* For literature, see Author's references: A. O. A. Jour., Sept. and Dec., 1905; May and Aug., 1906; June, 1911; Sept., 1912; A. T. Still Research Institute Bulletin No. 1. The publishers have kindly permitted the use of the above articles.

can be wasted if the leverage is not right; otherwise comparatively few pounds' exertion will accomplish the result. A simple way is to place the animal flat upon the belly, and thoroughly relaxed; then, while an assistant bears down with his thumbs upon the selected vertebra, the operator grasps the animal by the hind legs and exerts traction in line with the spinal column until the spinal muscles thoroughly relax and stretch; then immediately, while still maintaining the traction, hyperextend and rotate the spine until the desired point is felt to give and slip. Or, while still maintaining the traction, have the assistant suddenly exert pressure, a thrust, upon the desired vertebra. It is simply a question of applying the indicated mechanics. Various leverages may be utilized. Frequently we place a small block transversely under the animal, directly beneath the fulcrum, which assists in separating the parts to be lesioned as well as rendering the field a little more stable.

The traumatism is not carried to a point whence tissues are torn or lacerated. The object is to obtain a slight slipping or mal-adjustment of the articular surfaces. If done correctly—that is, specifically—little force is required. The immediate noticeable results are malalignment of the vertebræ, malposition of the ribs corresponding to the damaged vertebræ if the lesion is a dorsal one, and contraction of the spinal muscles of the same segments. These changes are readily palpated. After recovery from anesthesia the above characteristics are evident, with the added ones of tenderness and rigidity. Superficial muscular contraction usually subsides, but not always, until only the deep spinal muscles adjoining the lesion are palpably contracted. In some cases it is noted that upon movement the back is stiff and tender. In others such is not the case, and they shortly show no apparent ill effects. Later on a number present more or less systemic disturbances, depending upon the locality of the lesion. The periods of observation have ranged from three to eighty days—that is, the time from production of the lesion to autopsy.

**DISSECTION OF THE LESION.\***

Before the lesion is dissected a thorough autopsy is made in each case and specimens secured of various organs and tissues, whether they show any pathological changes or not, or correspond nervously with the osteopathic lesion. The special reason for the microscopic study of so much material will be stated later.

The dissection of the lesion and the securing and fixing of the specimens is executed with much care. After a thorough examination of all the viscera and tissues, with the exception of the brain, is noted, resection of six to eight vertebræ, including the ribs and contiguous muscles, ligaments and nerves intact and *in situ*, is made; that is, the spinal-column segments two to four vertebræ above and below the lesion are removed in order to facilitate careful and expeditious dissection and examination. At this point, and up to the severance of the damaged constraining ligaments, malformation and rigidity of the lesion is readily noted. Even the contracted muscles and parts of muscles do not relax. It is the deep contiguous muscles of the multifidus spinæ that are most involved. The spinal muscles are carefully separated and removed, as well as the nerve fibers supplying the same. Next, the sympathetic chains and their connecting fibers and rami are removed with as little traumatism as possible. Frequently small hemorrhagic points are detected in the sympathetic tissues corresponding to the lesion. Following this the ribs are removed and the intercostal nerve, artery, and vein retained. In a few instances bundles of intercostal muscle fibers are found contracted, and also slight hemorrhages of the surrounding intercostal tissues are detected. After the spinal muscles, ribs, sympathetics, and intercostal structures have been dissected and removed, the rigidity of the remaining vertebræ does not seem to be specially impaired. The next step, separation and removal one by one of the six or eight vertebræ, requires particular pains. Severance of the articular ligaments and dissection of the tissues intact

---

\*I am specially indebted to my associate, Dr. Frank C. Farmer, for valuable aid and suggestions. He has done most of the dissection, which in itself requires unusual experience and skill.

passing through the intervertebral foramen require considerable skill in order not to produce artefacts. Also, great care has to be taken in separating the spinal-cord membrane from its suspensory ligaments and tissues.

In the lesion itself, we fail to see where there is any perceptible partial occlusion of the spinal foramen by the encroaching bony tissues in the great majority of cases. Slight tension of the incased fibrous tissue anchoring the structures passing through the opening may readily occur. This in itself, in one sense, will act as an occluding factor. But careful microscopic examination does not reveal any greater damage to nerves or vessels here than at several other places, and the theory of pressure or inhibitory lesions *per se* at this particular area is untenable. Strain of the spinal-column muscles alone, especially an unbalanced tension, will unquestionably produce a temporary lesion, but not often a permanent one. After a number of days' rest the muscles will, to a great extent, return to the normal, unless there is a very active disturbing factor, such, for example, as considerable inflammation. Even in those cases where there is marked contracture, complete removal of the muscles produces very little, and at times no perceptible, palpable change in the vertebral rigidity. This does not apply, however, to ribs, for removal of the intercostal muscles allows comparative freedom of the range of rib movement, owing to the relatively small articulating surface. Consequently, it is found that the permanent vertebral lesion is maintained by overstretched and damaged articular ligaments. Sever either the capsules of the articular processes or the ligaments of the vertebral bodies and considerable motion is immediately obtained. The ligaments of the articular processes are the ones most damaged. The intervertebral cartilages of the articular surfaces are commonly little involved. This last statement, however, applies to slight and moderate lesions. Naturally, in more severe injuries ankylosis occurs, which happened in two of the animals. These observations apply particularly to the dorsal and lumbar sections. The cervical region is different structurally; here, for one feature,



larger and stronger muscles is an important consideration. Uneven traction of cervical muscles followed by contracture can easily produce and maintain an osseous lesion. Finally, one other point in the lesion involvement is frequently noted, hemorrhagic points within the tissue surrounding the dorsal and ventral root bundles and within the membranes of the cord (notably between the pia and arachnoid).

### THE MICROSCOPIC EXAMINATION.

First, a word or two relative to the preservation of tissues. This is a most important part of the work. Too much care can not be given to the dissection. The tissues should be both gently and expeditiously handled. The least possible traumatism is demanded. Animal experimentation, in our opinion, is far preferable in the study of the osteopathic lesion to the dissection of the human cadaver. In the former we have the unequalled opportunity of examining absolutely fresh and unchanged post-mortem material. And in the dog the anatomical and physiological variations from the human are practically nil so far as important, critical, and dependable observations and study are concerned.

The various well-known fixing fluids are used, such as alcohol, formalin, Muller's, Orth's, Flemming's, etc., selected according to the various tissues retained and the several staining methods to be attempted. As a special precaution portions of the same specimens are fixed in more than one fluid and stained by more than one method. For an additional "control," in order to reduce errors to a minimum, various normal specimens are passed through the same fluids and stains. As to the "control" features and the several technique methods, more will be said later.

Naturally, the greatest interest centers in the microscopical findings of the nerves and blood vessels. The Marchi, Weigert-Pal, Williamson, and Nissl methods show, without question, that the nervous structures of the spinal cord, the spinal nerve

---

NOTE: The following photomicrographs are selected from those published in The A. T. Still Research Bulletin No. 1. Photographic work done by Mr. F. T. Harmon, Chicago.

roots and their branches, and the sympathetics corresponding to the lesion, are pathologically involved; while nervous tissues of normal animals, fixed, stained, and mounted in the same material and at the same time, show no change. Various cell groups in the gray matter are disturbed; some are more or less swollen, others partly atrophied, and a number normal (Williamson and Nissl's methods). Corresponding axon degeneration (beginning parenchymatous; Marchi, Donaggio and Weigert-Pal methods) is readily noted, and extends above and below the lesion. Our studies of the cord have embraced only two or three segments above and below the lesion. These changes can readily be classed as primary degeneration, which means that the nerve cells are nutritionally disturbed. They are not, as a rule, very extensive

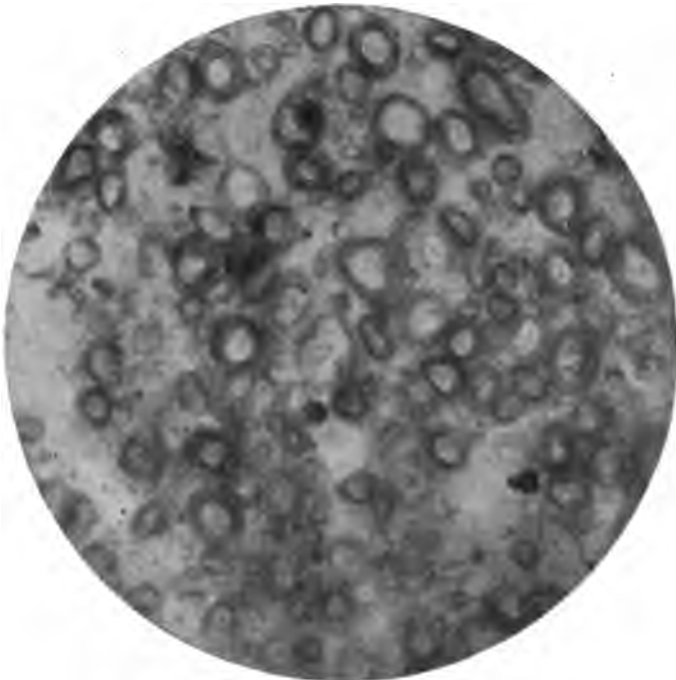

FIG. 48.—Normal nerve fibers of the spinal cord (posterior column). Marchi. X 400.

or severe, but can readily be traced from the nerve centers in the cord and posterior root ganglia and sympathetics. In many instances they do not include the entire bundle of axones, but one-third, one-half, or two-thirds; in some an entire cable is degenerated. The posterior nerve roots are most affected, frequently all the fibers. The anterior roots are usually less involved, commonly bundles of fibers, not the entire section. In cases where the lesion is more severe or the back being stiff for more than two vertebræ, the neighboring spinal nerves are found more or less degenerated.

We have not been able to always clearly trace the degenerated paths in the cord (one reason being the paths in the dog are not so clearly defined as in the human). But the following paths are noted: (a) Definite paths of degeneration in the entry zone and in the posterior column, the fasciculus gracilis (Goll's tract) and the fasciculus cuneatus (Burdach's tract), also scattered fibers corresponding to the descending postero-medial and postero-lateral tracts; (b) Posterior cerebello-spinal tract (direct cerebellar tract); (c) Ascending anterior cerebello-spinal tract (Gowers' tract).

It should not be understood that these degenerations have destroyed the tracts; within all probability they are amenable to treatment. In some cases many fibers are affected, in others only a few. The question of regeneration within the central nervous system at once arises here, owing to the fact that the fibers have no nucleated sheath of Schwann. We think it probable that moderate changes, due to the osteopathic lesions, are amenable, whereas a degenerated lesion would not be. At any rate, in those cases where comparatively few axones are involved the ultimate results may not prove especially serious, owing to the large number of axones, provided the original cause is removed, thus eliminating further disturbances.

Degenerative changes have not been found in every case, but in the majority of cases. These changes have been constant as to locality, and correspond, we believe, to the above named tracts, although as to the latter it is possible we are mis-

taken; and it should be noted that all of the degenerated paths named above are not necessarily found together in the same specimen. Evidently a series of lesions (osteopathic) of apparently the same character may cause a variety of pathologic disturbances. The lesion may involve nerve fibers singly, in groups, or possibly the entire nerve-trunk; or certain groups of nerve centers or certain cells of groups may be involved. Interesting examples



FIG. 49.—Transverse section of nerve fibers in the posterior column. Beginning parenchymatous degeneration. The medullary sheaths are largely broken down. Marchi. X 350.

are: The vascular supply of the lateral cell column is independent of that to the motor cells of the ventral horn; differences of function are shown in the myelination at five different periods of the dorsal roots and dorsal columns.

It is claimed that most of the nervous impulses from the joint surfaces, ligaments, tendons, muscles, and skin, pass from the end-organs through the spinal ganglion to the posterior column and into the fasciculus gracilis or fasciculus cuneatus.

It is readily seen how important it is that the **joint surfaces, ligaments, muscles, etc.,** be normal, responsive, and not held immovable and inactive through osseous or muscular lesions, or weakened through lack of exercise. We are of the opinion that it is largely through the ligamentous changes that the lesion is maintained.

In the nervous tissues we have found the greatest involvement with the primary sensory neurons. It seems to us that herein, to an important extent, lies the inception of the osteopathic lesion. Probably most of the impulses, muscular and tactile, from the viscera pass through the posterior roots of the spinal nerves to the posterior cerebello-spinal tract. It will be recalled that this tract is considered a sensory path of the second order. It originates from Clarke's column (an area at the inner angle of the base of the posterior horn).

The changes here have not been noted so frequently as in the posterior column, one probable reason being that osteopathic lesions vary as to severity and extent of involvement. Every lesion does not necessarily result in a viscus effect; and it may also be said every viscus effect is not always demonstrable pathologically, depending upon severity of lesion, length of time, character of viscus tissue involved, and how disturbed.

Several possible explanations as to the cause of the disturbance of this tract will suggest themselves. Among the most likely we would place first, vascular changes in the cord due to reflex vasomotor ataxia.\* The vasomotors enter by way of the posterior root. Then, of course, the impulses of the primary sensory neuron are disturbed even before the cells of Clarke's column are involved. Another concomitant, or possibly independent factor, is the pathologic changes of the visceromotors due to impairment of cells in the anterior horn. We do not wish to theorize here, but rather to state a few possible explanations in order to emphasize the pathologic findings.

Relative to the third tract we have noted in this report, the ascending anterior cerebello-spinal tract, various investigators

\* See McConnell, "The Vasomotors," A. O. A. Jour., Mch., 1912.

have stated that probably pain and temperature impulses pass this way. (The dorsal nucleus—Clarke's column—also carries painful and thermic stimuli.) This tract is probably also a sensory path of the second order and arises from cells between the anterior and posterior horns. To complete the picture of the posterior root fibers, it may be well to recall that within the cord they divide, one branch passing up within the posterior column, the

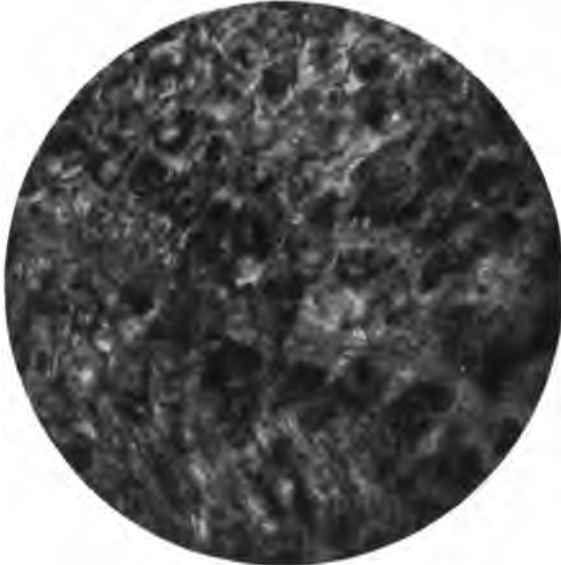

FIG. 50.—Beginning parenchymatous degeneration of medullated axones of the anterior spinal nerve near the cord. Marchi. X 350.

other downward in the comma tract for a segment or two. Collaterals from both are given off to the gray matter of the immediate and upper and lower segments. The collaterals form connections with the anterior horns (skeletal reflexes), posterior horns, lateral horns (visceral reflexes), and Clarke's column.

The lower motor neuron rises from cells in the medial, lateral and intermedio-lateral columns on the same side and from the medial column of the opposite side. The voluntary motor fibers originate in the anterior column; and the involuntary fibers,

sympathetic in function, vasomotor, visceromotor, secretory, inhibitory, rise from the intermedio-lateral column.

In all of our pathologic findings it seems to us the most significant changes are those of the vascular changes to the ganglia—posterior ganglion, cells of the grey matter of the cord, and sympathetic ganglia. Part of the pathology may possibly originate from three sources; probably these are factors of varying and various degrees: (a) blockage of normal impulses followed by retrograde changes; (b) vasomotor ataxia; (c) traumatic (strain and stress) effect to vascular and nervous tissues due to the subluxated segment. However, the most significant basic and permanent change arises from reflex rather than direct causes.

An important negative feature is that we have found no changes in the axones of the higher motor neurones. Our data is based upon the dorsal segments. The most pronounced fiber changes are found in the primary sensory neuron and the lower motor neuron. These degenerations in the well-marked lesions are the same as the others heretofore reported. They are found in both halves of the cord, and substantiate the conclusion that the osteopathic lesion effect is a reflex effect and not essentially a pressure upon the tissues at the point of the spinal foramen exit.

Pathology is the same usually in both halves of the cord, showing that the primary sensory neuron involvement of either side is practically equal; the lower motor neuron is degenerated (but not of a Wallerian character) primarily from vascular changes in the cells of the anterior horn (the higher motor neuron is normal), and retrograde changes are not an important factor.

The affirmative evidence of greatest weight might be that pressure at the foramen would disturb the primary sensory neuron and the vasomotors to the spinal cord, the latter resulting in vascular disturbances to cells of the motor neuron. In this case it would not be likely that the pathology of both halves would be the same. One will readily grant that the spinal foramen of the opposite side, toward which the spinous process is rotated, tends to encroach upon the same (spinal nerve), and that the training of the firm anchorage about the fibers of the other side



FIG. 51.—Beginning parenchymatous degeneration of the medullated fibers of a section near the posterior root ganglion. Some of the fibers are cut transversely, others longitudinally. Marchi. X 350.

by separation would act as a blockage.\* But the explanation of all the pathology, even in this instance, would be more upon the plane of reflex changes than of direct pressure.

Every osteopathic physician of experience is well aware that an impacted, rigid, or fibrous ankylosed (articular process) lesion is of more serious consequence than a marked twist accompanied with greater motion. Then physiologically the functional inception of nervous activity is afferent integrity, with a reflex arc and efferent channel as a structural fundamental.

We do not wish to imply that the pathology of the osteopathic lesion always signifies a serious condition any more than when one is not feeling well his condition is desperate; but we thoroughly believe that it is a demonstrable lesion pathologically as well as clinically; that it is a frequent and important etiologic

\* Clinically it is commonly noted that the greatest tenderness is on the side toward which the spinous process is rotated.



factor; that it demands specific interference; and that if adjusted and left alone, recovery is the rule.

The degenerated fibers in the sympathetics appear to be largely those of the vasomotors (fine medullated groups, Marchi method), but this is a difficult point to positively decide. These early changes are, as a rule, a simple beginning primary parenchymatous involvement, and no doubt are amenable, in the majority of cases, to recovery when the disturbed nutrition is rectified.

The changes found in the blood vessels are a highly interesting and elucidating study. The coats of arterioles, capillaries, veins, and in some instances the arteries, are found deranged from the endothelial cells through the muscle fibers and the outer layer into the surrounding tissue. And in the walls through and into the surrounding tissues are found, in variable quantities, blood corpuscles enmeshed. From an escape of blood plasma to leucocytal invasion, diapedesis and hemorrhagic foci, the pathologic picture is evident. The change is not an intensely destructive one, or one beyond a stage of repair. The entire transverse wall is not, as a rule, involved, only a portion. In a number of the smaller arteries there is a well-defined endarteritis. The involvement is a hyperemic one, in all probability dependent upon vessel relaxation and atony, followed by plasma leakage between endothelial cells and escape of corpuscles. This distortion in localized areas of the vessel's wall structures is undoubtedly pathologic, due to the varying diapedetic activity. It is specially interesting to note that considerable diapedesis occurs about and through the ganglionic regions of the spinal cord, posterior root ganglion, and sympathetics. This vessel disturbance always largely corresponds to the osteopathic lesion so far as the involved spinal foramen (both sides) and the injured ligaments and muscles are concerned. In many of the dissections the nerves, vessels, and connective tissue of the spinal foramen are removed intact, likewise the sympathetics and the tissues of the back, so that thorough and comprehensive pictures of the lesion are thereby secured. The rich nerve and vessel supply to and through the

fascia is an interesting study in itself. All of the pathologic changes do not correspond absolutely to the osteopathic lesion, but the changes above and below are much less marked, and undoubtedly are due to either extension of the traumatic lesion or to related nerve paths (probably the latter). In those cases where the mechanical injury is not entirely confined to a single articulation, pathologic involvement elsewhere is noted corresponding to location and degree of initial damage. Then, of course, as stated, there is the ramification of fibers above and below the segment that should be remembered. The disturbances to the vessels of the sympathetic seem to be just as well marked, but it is to be noted they are less severe in the adjacent segments above and below. The extension of this vasomotor affection to nervously related viscera—for example, the stomach and kidneys—is frequently detected; but visceral lesions will be discussed presently.

The hyperemia in the spinal cord is pronounced, especially in the gray matter. Throughout the posterior horns and the tips and mesial sides of the anterior horns are the areas most disturbed, but not by any means exclusively. The circulatory changes vary in different cell groups. This ischemia is greatest in the corresponding segment and gradually lessens to a segment, sometimes two, above and below the lesion. Congestion, with more or less diapedesis of the anterior and posterior spinal-cord vessels, is readily noted. In the majority of cases the posterior vessels apparently suffer the more, the same as the posterior nerve fibers. The additional strain to the anchorage and connective tissues in the spinal foramen may partly account for this; it may be due partly to the peculiarities of vessel distribution and termination, and to the fact that the spinal veins have no valves. Anticipating, for a moment, a portion of the theoretical conclusion, for the sake of emphasis, it would appear that the damage, inceptively and primarily, would be due to the blockage of the afferent sensory impulses of the joint structure and encompassing tissues, followed by reflex segmental disturbance to the efferent vasomotor, motor, and other fibers. In this connection it would be interesting to know the relative severity of nerve cell and fiber

change due to a disordered viscus,\* affecting reflexly the viscerosensory and visceromotor reflexes. Hyperesthesia and muscular contraction of the spinal tissues arising from viscus disturbance is a frequent observation, and we profit clinically by these symptoms. Severance of the afferent fibers from viscus to cord and



FIG. 52.—Nerve cells, axis cylinders and vessels of the tip of the posterior horn. This specimen shows only slight involvement. Compare with next figure. Williamson. X 120.

a histological study of its effects would probably instruct us considerably.

These changes, as stated, are detected in varying degree in nearly all the arterioles, capillaries, and veins. But in the tissues above and below the lesion there is marked diminution in both

\*See Weigs, "The Origin of Disease."

degrees and number of vessels involved. Various well-known methods are employed, such as Orth's fluid, formalin, alcohol, etc., with hematoxylin and eosin or congo red, and the Marchi methods with, at times, an additional lithium carmine stain. At the same time, invariably, normal tissues are run through the same fluids as a check. These lesions are acute pathologic disturbances, and not chronic ante-mortem disorders due to other causes, or post-mortem changes or artefacts.

The microscopic muscular changes are clear and well defined. The contracture is due to an interstitial myositis, wherein is easily seen increase of connective tissue and atrophy of the muscle fibers. It should be remembered that more or less initial muscular contraction subsides after two or three days, and that contractures do not, as a rule, embrace all of the muscle fibers, but certain groups. The deepest layers, those when contracted giving the sensation of a whipcord on palpation, are mostly involved. Sometimes only one side is affected. The nerve to these fibers is found degenerated, as well as the related arterioles and veins. The nerve degeneration is due to the nutritionally disordered cells of the anterior horn. We do not believe the muscle disorder is due to direct traumatism, for certain it is that many of them are not factors in maintaining the lesion. This statement should not be misinterpreted clinically, for unquestionably muscular contractions and general muscular tone is a factor to be reckoned with in both producing and adjusting a lesion.

It is the ligaments that maintain a lesion of the chronic type. The injury here is considerable; not necessarily in the sense of lacerations and general exudative sequelæ. But the ligaments are strained and stretched, and more or less hyperplasia follows. Proliferative changes and thickening are observed. Arthritis involving the cartilages of the articular processes is not the rule. In most instances the cartilages of the articular processes are normal, as well as the intervertebral disc. But the ligaments inclosing the former suffer more than those of the latter. The osseous tissue is histologically normal.

Here a word of caution may be justified. In this study of

the lesion an attempt has been made to determine just what the lesion is—that is, the initial pathologic changes, not its many possibilities and variations. There must be definite general underlying principles. Our aim has been to seek these, rather than to cover the field of pathology, with its many varying phases.

### THE VISCUS EFFECT.

The effect of osteopathic lesions upon viscera is more readily studied, owing to the easier technique of dissection and staining. In addition to the histologic methods, at least two important organs, the stomach and kidneys, can be clinically studied by means of chemical and microscopical analysis. In this sketch it does not seem necessary to go into innumerable details. We are of the opinion that an outline statement of the facts, with a presentation of a few photomicrographs, will prove of considerable interest to the osteopath.

The lesion effects upon viscera correspond definitely to the path of spinal innervation. It would seem that, fundamentally, impairment of the vasomotors plays the important *role*, although undoubtedly disturbance of visceromotor, secretory and other nerves are necessary factors, and herein, probably vessel relaxation would take place as a reparative process. Congestion and inflammation are basic to the large majority of diseases, and in all of our experiments we find vessel disturbance a constant feature, whether in the immediate locality of the osteopathic lesion or as a remote effect, but still related physiologically by way of the nerve centers. Consequently, we conclude some involvement of the vasomotor mechanism is fundamental to at least a large portion of visceral lesions. Remember we are considering only the osteopathic experimental field as it is presented to us, and not attempting to correlate it with other undoubted etiologic factors. The effect upon stomach and intestines is marked. First, clinical analysis shows that secretory, motor and digestive powers are altered and lessened; that is, of course, if the osteopathic lesion is a fairly deep-seated one, affecting the stomach innervation.

Then the histologic examination reveals one or more characteristic pathologic changes. In the lesser changes, as in all, we note vessel congestion in the submucous coat. Usually accompanying this is diapedesis. In the more marked cases the cells of the mucous coat are nutritionally involved; there are areas of feeble staining and parenchymatous changes, with accompanying pathologic disorder. This is found in areas of both the stomach and intestines. These changes, like all the visceral ones found, are definite acute ante-mortem lesions. At most, the period of time from death of the animal to the tissue being placed in the fixing fluid is only a few minutes.



FIG. 53.—Area near the tip of the posterior horn. Same animal as figure above, but different cell group. Note the beginning degeneration of the nerve cells, the pericellular spaces, the swollen axis cylinders, the several hyperemic vessels, and the cell infiltration. Other groups were found still more disturbed, some less so, while a few are normal. It does not seem there can be any question but such lesions are important sites for further pathologic involvement. Williamson. X 120.

The kidney changes are very interesting. These have taken place when the lesion was produced in the section comprising the eleventh, twelfth, and thirteenth dorsals only. It would seem without question that the vasomotors are principally at fault—that is, the initial nervous lesion affecting the kidney is by way of these fibers. The disturbance is a vascular one, resulting in congestion and a typical hemorrhage infiltration. The nephritis, of course, is acute, and the urinary findings are characteristic of such. The urinary changes are commonly manifested the third day, sometimes the fourth and fifth. In two cases correction of the lesion was attempted, and in ten and fifteen days respectively the urine was negative and remained so. An interesting point to note is that the vascular disorder seems to occur first in the glomerulus, and between the glomerulus and capsule; then throughout the tubules. There is probably an anatomical reason for this, due to the vessel's distribution and ending in the tuft.

In our experiments the most frequent lesions have occurred in stomach, intestines, and kidneys, for we have experimented principally with lesions to these organs. And visceral changes occur only when the vertebral perversion corresponds to the respective viscus innervation. The nervous distribution in the dog is nearly the same as the human. Those organs having the greatest and most sensitive nerve supply are naturally the quickest and easiest affected.

The liver and spleen in a number of instances were found congested. The liver, especially in areas in the middle lobe, was involved, and the cellular tissue nutritionally affected. This was shown by feeble staining and perivascular infiltration.

In two cases the pancreas was found acutely disordered. There was considerable congestion throughout several of the islands of Langerhans (and further study and experiments may reveal that this precedes the atrophic changes noted by Opie). The urinalysis after the fourth day showed a moderate amount of sugar.

The adrenals in one case of lesion of the lower dorsal showed a small amount of congestion.

A parenchymatous goitre was definitely produced in two of the animals. One of these had a lesion between the second and third cervicals; the other case between first and second dorsals. In both of them several of the near-by lymphatics were enlarged. Occasionally the lymphatics, especially near the liver and intestines, when these organs were disturbed, showed enlargement.

All of the visceral lesions were of an acute character and correspond definitely with the vertebral or rib lesions. The reader is referred to the cuts for more detailed information.

In later experiments (partly reported in A. O. A. Journal, June, 1911, and others not completed) the spleen, pancreas, and adrenals were involved. Goitres have been produced and cured in the same animal; this between second and third cervicals (probably vasomotors).

#### THE CONTROL.

We are aware that in most experimental work an important part is the so-called control. The work parallels surgical experimentation in so far as many of the principles are concerned. Care has been taken in the selection of suitable material. Normal animals have been dissected and the tissues microscopically examined. Almost invariably specimens of the several viscera not physiologically connected with the lesion have been preserved; normal nervous and vascular tissues above and below the lesion, even from distant parts, as a leg, have been retained; and all were fixed, stained, and mounted in the same manner and at the same time as the pathologic specimens. This in itself, to us, has been a very important control. The tissues were marked and detail notes made. The dissection was unusually careful, and with such accessible tissues as the viscera, sympathetics, and spinal intercostal fibers, there is no occasion for any damage being done. From the living tissue to the fixing fluid, no other method offers such a minimum of time for post-mortem changes. The pathologic changes are unquestionably ante-mortem, not post-mortem or artefacts. They are acute changes, not chronic



ones. The changes correspond to the osteopathic lesion, and this was shown by a variety of technique methods. Finally, clinical data bears us out. Probably a section of certain nerve fibers (other than has already been done) contiguous to the spinal structures would reveal some interesting data, but this requires a high



FIG. 54.—A normal cell from the posterior horn of the spinal cord. Note the Nissl granules. Nissl, Gothard, Luithlen and Sörgo's modification. X 600.

degree of surgical skill, and, moreover, a thoroughly trained physiologist can do it better, and we have access to their contributions.\*

### CONCLUSION.

In conclusion, therefore, the following points are submitted bearing upon the theoretical and practical interpretation of the osteopathic lesion. It seems logical, in view of the above facts, that the explanation of the osteopathic vertebral and rib lesion rests upon something more than mere pressure of maladjusted

\* In our later experiments we have added the control features adopted by Dr. Deason.

tissue upon nerve fiber or vascular channel; this at best can be only a part of the pathological process. In the first place there is a physiological disturbance of the muscular, fascial, ligamentous, and osseous tissues, which causes interference with the normal afferent influences to the spinal-cord centers, and this is more or less permanently maintained by the lack of freedom of the normal joint movements. This obstruction of normal afferent stimuli is only the initial step, for disturbance of innervation through the mechanically changed relationship of the structures, physiology teaches us, initiates a corresponding and dependent change in the spinal-cord segment. The immediate contraction of the muscles, for example, and their maintenance show this to be the case. Such interference of the ever constant nerve force must necessarily disturb functioning, and, as a consequence, the subsidiary vasomotor centers, with others, are affected. Mere inhibition of part of the nerve current, causing resultant disorder or certain reflex arcs, would probably affect nutrition. But we find vessel relaxation and congestion a prominent feature. The arterioles, capillaries, and veins are pathologically affected by the disturbed innervation. The blood stream is slowed, the endothelial tissue compromised, and plasma exudation takes place. This is followed by diapedesis even to the frequent extent of hemorrhagic foci, especially in and about the nerve centers of the cord and ganglia; and thus nutrition of the local parts is jeopardized. This, then, means that the nutritional centers, the ganglia, will not receive their full quota of nourishment, and thus the integrity of the neuron is impaired and primary parenchymatous degeneration follows. This, we believe, is the explanation, of at least an important part, of the pathologic inception of the osteopathic lesion. Other factors may eventually prove to be important contributing features, but our special purpose here has been, if possible, to offer an initial working basis.

Neither macroscopic nor microscopic findings of the tissues passing through the spinal foramen warrant the assumption that the osteopathic lesion is the result of mechanical pressure *per se* in this region. No doubt strains and tension of the fibrous and

connective tissues here, as elsewhere (and possibly even more so owing to the firm anchorage of the tissues), would have their effect upon nerve impulses and vascular channels, but the histological findings are no more pronounced here than in other structures. There is nothing in the examination to lead the writer to conclude that the foramen is distinctly lessened in diame-

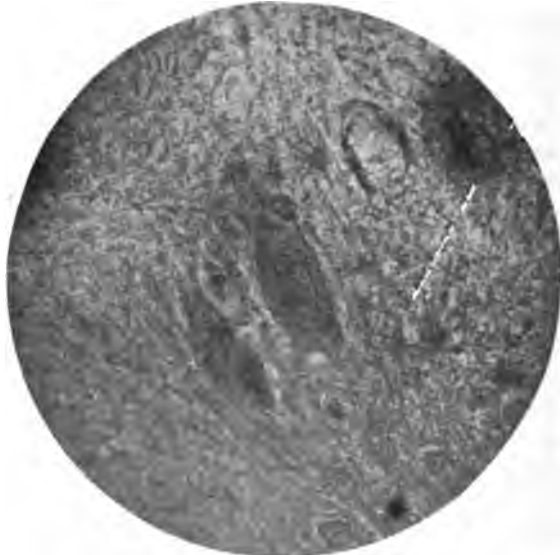

FIG. 55.—Degenerated cells from the anterior horn of the spinal cord. The upper cell shows chromatolysis; the cytoplasm is swollen and the nucleus has moved toward the periphery. The lower is in a stage of atrophy. In the upper right and left periphery of the cut are seen two hemorrhagic areas due to venous hyperemia. Nissl, Gothard, Luthien and Sborgo's modification. X 600.

ter so that it encroaches upon the conducting organs, or that there is distinct pressure upon artery, vein, or nerve. The morbid histology is the same here as in the corresponding parts. Naturally, it would take but little strain to disturb nerve currents, but it is in the ganglia that the greatest vascular change occurs, not along the conducting fibers. Although vasomotor tone, locally, even to the point of diapedesis, may occur from mechanical means or trauma remote from a center, still it seems to us the phenomena

of the osteopathic lesion, clinically and pathologically, point distinctly to a central or focal irritation (cord); and, moreover, the changes in the spinal nerve, artery, and vein would be localized in character resultant changes would be different, and less systemic and less evenly distributed pathologic involvement if the lesion was primarily a blockage at some point within the spinal foramen. And, moreover, the degeneration is not Wallerian after the manner of a distal end separated from its center. Two or three anatomical features stand out prominently in the dissection of the spinal-column tissues, viz.: the close contact of the spinal nerve, artery, and vein to the superior border of the rib and their firm anchorage within the foramen, clearly exhibiting how easily the maladjusted vertebra or rib may disturb these tissues; the fairly loose anchorage of the sympathetics, by the parietal layer of the pleura, along and near the head of the ribs, also suggesting that rib lesions may disturb sympathetic integrity. However, at best, from our observations, pathologic changes here can be only a part of the entire morbid picture.

In the large majority of cases only a portion of the cells are affected, likewise the axones. Segments of the cord, as is well known, are neither histologically nor physiologically isolated, so to speak; neither is the osteopathic lesion a complete severance, organically or functionally, of a certain segment. Certain paths are more disturbed than others; and from all indications the entire neuron suffers, thus pointing, nutritionally, to a central effect, with a corresponding disturbance to the subsidiary and collateral neurones. This accounts for the pathologic changes in near-by segments and ganglia, and, indeed, for the effect upon related viscera. No doubt the majority of these early changes are amenable to treatment, for the degeneration has not often gone beyond a stage of repair. Many lesions, if not all, unquestionably lower the amount of vitality a related tissue or organ should receive, and thus are important predisposing etiologic factors.

Nervous tissue, particularly the ganglia from the cord to the sympathetics, and the connective tissue are richly supplied

with blood (which always indicates intense physiologic activity). This point can not be too greatly emphasized. Osteopathically, the greatest disturbance seems to be in these nerve centers. Owing to the sensitiveness of nerve cells to circulatory changes, it is a slight step from functional impairment to organic disorder. When such occurs it is only another short step to visceral impairment. The same lesion, apparently, may affect the tissues differently—that is, as to precise locality—although all lesions affect the tissue more or less the same pathologically. Physiologically and clinically we know, owing to the neuron morphology, that certain paths are related anatomically and physiologically to different segments; likewise tissues and viscera to different segments.

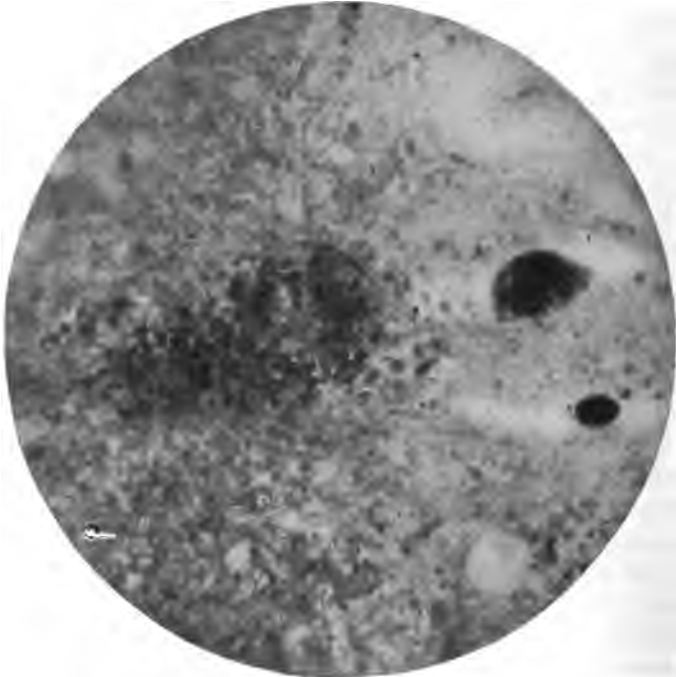

FIG. 56.—Diapedesis in posterior horn midway of base and tip. The two dark spots are engorged and dilated veins. The mass of blood corpuscles to the left is from the larger vessel. This is only one hemorrhagic spot of several in this specimen, some larger and others smaller, scattered throughout the gray matter. X 325.

Practically, a thoroughly related structure and a definite technique are conducive to either production or correction of the osteopathic lesion.

There can be no question experimentally, as is well known clinically, that the osteopathic lesion is an important etiologic factor in visceral perversions. We have touched upon the probable pathologic explanation, the importance of vasomotor disorder, in explaining the pathogenesis of visceral lesions wherein the osteopathic lesion is the etiologic factor. It would seem that Dr. Louisa Burns' excellent experimental work would have an important bearing upon this point. However, this phase of the work, the same as the remaining portion, is presented for what it may be worth. This is merely a start; but we feel justified in saying that we firmly believe the experimental side of osteopathy, like the clinical, merits the earnest attention of the entire profession. We are content for the moment, as has been stated, to let the facts speak for themselves; theoretical interpretation to a finer degree rightly comes later, when we have much more data.\* There is an additional practical point we believe should be specially emphasized, namely, the importance of leaving the osteopathic lesion alone when once something had been accomplished. Dr. Still has continually spoken of this, and experimental work substantiates it. Too many of us treat too often and too hard, and thus do not allow nature a fair opportunity to repair the weakened tissues.

---

\* We firmly believe the osteopathic lesion has a very potent bearing etiologically upon cellular changes. "Variations in minute detail of colloidal arrangement in itself, and in relationship to dissolved pabulum in the shape of organic and inorganic crystalloids, lie at the root of the varying activities of the cells, and of all physiological and pathological changes." (Benjamin Moore, "The Origin and Nature of Life.")

## CHAPTER XLIV.

### THEORETICAL.

We are prone to overlook the unity of the body. We disarticulate the mechanism at the expense of emphasizing its unity of structure. No doubt nerve roots present distinct functions, but we should not err by thinking these functions are entirely independent. All cells of the body are brought into relation and conjunction through the nervous system. Comparative anatomy and embryology teach us it is the nervous system that unifies the parts. There has been a gradual separation or integration of the body unit with a corresponding co-ordination of its functions.

The innumerable afferent impulses, the continuous flow of sensory nervous force (not necessarily implying consciousness), the relation of receptor to effector, the so-termed nervous tension due to our external and internal environment is a fundamental essential to well being. This slight and imperceptible current of impulses, constantly present, maintains the tone.

Sensation induces motion and motion induces sensation,\* both controlled by separate parts of the same nervous mechanism, but mutually dependent. And in health there is a constant sensory tone as well as muscle tone. Variation of environment necessarily produces a change of tonic stimulation. In just so far as the body mechanism responds and reacts to tonic stimulation through its integrals and their co-ordinating functions will the effects be stimulating or depressing. Important factors are the environmental changes, the *intactness* of the nervous mechanism, and the integrity of the nutritive supply. We will not go into details relative to the first. Nevertheless it covers a wide

\*Morat's "Physiology of the Nervous System."

field from temperature changes, physical and chemical surroundings, sanitary conditions, dietetic habits, to mental attitudes and situations. Herein we are especially interested in the blockage of the afferent impulses following a certain condition that may arise, viz., structural perversion—the so-called osteopathic lesion.

It is evident from the teachings of physiology that any “structural perversion which by pressure produces or maintains

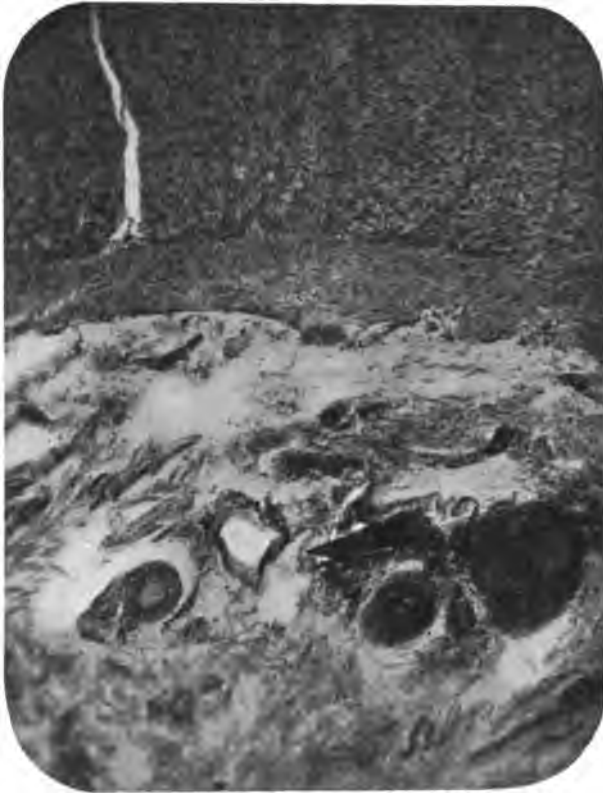

FIG. 57.—Passive congestion of stomach as shown by the extreme dilation of the vein, the ecchymosis, and the actual hemorrhage outside of the vein. This depicts lack of tonicity and early degeneration of the vessels. Hematoxylin and eosin. X 75.



functional disturbance"\* must among its initiatory changes result in a cessation (partial at least) of the corresponding tension or tone. Consequently any physical lesion that lessens mobility, flexibility, elasticity of tissue, would be an osteopathic lesion. And in proportion to the extent of structural rigidity, its locality and its length of maintenance will dependent conditions be manifested.†

Physiology also teaches that the integrity of the neuron is dependent upon at least two important conditions; first, its nutritive supply; and, second, nervous impulses. Lessen either the nutrition or the ever constant nervous tension, and a corresponding body change will be instituted. Immobilization of a spinal area, of muscular unbalance is just as much a lesion, although not necessarily a serious one, as a severe rotation between two vertebræ. This condition is an external environmental one and disturbs the nervous mechanism after the same manner (fundamentally) as an appendiceal lesion or an obstructed common bile duct. In each instance the effect is primarily an afferent one by way of the posterior spinal ganglion to the associated neurones of the reflex arc. The inception exemplifies an exaggerated physiologic state which, if the lesion is maintained, soon passes into a so-called pathologic condition.

It would not be physiologic to assume that the disturbance in its effect rested here. Neither is it necessary to step outside of physiologic teachings to assume that the above initiatory change is due to a partial closing of a spinal foramen with consequent pressure on an emerging axon,‡ or to assume some fanciful idea that the lesion is due to "pressure" on some "osteopathic center." If either of these conditions were present treatment of the condition would pass into the realm of operative surgery. Much of the misinterpretation arises here from our misunderstanding of fundamental anatomy and physiology (although even of this we

\* Hulett's "Principles of Osteopathy."

† "The nutrition of the nerve cell depends to some extent on its systematic activity. Disease may lead to degeneration, and degeneration or interference with the functional activity of one system produces an effect on the functional activity of another."

‡ Research Institute Bulletin, No. 1.

know precious little). We forget, for example, the ramifications of the primary sensory neuron and its extensive connections. It does not stop at the corresponding segment. Not only do many of the fibers extend upward into segments above in addition to the association neurones, but others extend downward into lower segments.\* Consequently, although we have so-called functional centers they are not entirely independent. We must ever keep in mind the concatenation not only of organ to organ through the several ferments, but that nervously there is a constant interdependence which not only controls and regulates the separate tissues and organs, but the mutual interrelation—the unity of the body—as well.

This view of the osteopathic lesion refers to the initiatory change only—the interference with afferent impulses. Something besides the immediately noticeable dependent motor change must take place, for the afferent impulses are essential to the nervous balance, equilibrium, of all the tissues, vasomotor and secretory and visceromotor, etc. Naturally, we think of the vasomotors first because they control that other master tissue, the circulatory system. And without proper nutrition more than without sufficient impulses will the neuron become impaired. Again physiology teaches us that if the vasomotor tone is impaired the vessel dilates, the blood stream is slowed, and the physiologic balance between the fluids of capillary and lymph space is disturbed.†

Although osteopathically the osteopathic lesion in its initiatory phase principally disturbs the well being of external environment, we should not overlook the physiologic importance of the internal environment as expressed through the nervous system. Either a vertebral lesion or an intestinal lesion will be manifested

\*"The articular surfaces of the bones are very richly supplied with sensory nerves. The axons of the sensory nerve cells, entering the spinal cord by its posterior roots, break into branches, a short one which descends to the first or second, rarely the third, segment below the point of entrance, and a long branch which ascends by way of the posterior tracts to the medulla." "Collaterals from axons of sensory roots enter into relationship with the nerve cells of the anterior horn. These collaterals, together with some axones from cells of posterior horns, carry impulses concerned in those reflexes which affect spinal and other skeletal muscles. Thus there is a path from articular surfaces to the spinal muscles that is involved by the bony lesion."—(Louisa Burns, "The Bony Lesion a Cause of Disease," Jour. of Osteo., Nov., 1909.)

†Research Institute Bulletin No. 1.

by reflex muscular contraction. In either instance a disturbance of afferent fibers initiates the effect upon the nervous tension or tone. Unquestionably this teaches us that internal afferent tone, for example, the alimentary tract, is essential to health, the same different in degree as external afferent tone.



**FIG. 58.**—An early parenchymatous degeneration of the mucous coat of the stomach as shown by the feeble stain taken up and in places by its complete absence. In a few places there is partial atrophy; this is limited to the glands themselves, and is specially shown at the free ends. Under high power cloudy swelling and degeneration of the base and nuclei can be seen. Hematoxylin and eosin. X 100.

We commonly think of motor and sensory spinal cord centers as being separate and distinct; such is true to a limited extent only, for both are interdependent. Other so-called spinal cord centers are vasomotor, visceromotor, reflex, etc. All are part and parcel of interdependent functions and all en masse are essential to the body unit.\*

So in a strict sense there is no such thing as an independent organ, pictured from the viewpoint of an entity. The vasomotors and visceromotors and secretory fibers must under health conditions receive their full quota of nervous tension or impulses. The osteopathic lesion will disturb this balance, from all the evidence, just as quickly as the sensory or motor balance, but not being related to so-termed sense organs directly, we are less conscious of the disturbance. Consequently, in all and through all, sensory, motor, vasomotor, visceromotor, etc., must we look for the beginning pathology.

As has been intimated, nerve centers are partially grouped anatomically as well as functionally due to evolutionary changes, but each segment is only partially an anatomic and functional center. The segments above and below enter anatomically, more or less, into direct relations whether we are considering spinal cord proper, posterior spinal ganglion, or sympathetics. Herein is suggested to a certain extent the key to characteristic osteopathic technique. Our work is to adjust specific anatomic lesions, that is, lesions of gross structural perversions (mechanical), whereby nervous tension has been more or less partially blocked. The majority of these lesions in order to specially affect a certain organ will be found within a certain area because within certain segments (not commonly a single one) are grouped anatomically the various centers functionally related to the organ. This must not be interpreted too literally for it is all due to a more or less definite change, as heretofore stated, arising from evolutionary forces. Thus segments are partially independent but all overlapping most intricately and all grouped together most complexly to form a unit. Vasomotor and visceromotor centers so far as

---

\*Hill, "The Body at Work."

organic life is concerned give rise to the nervous-center idea, owing to their great importance and to the definite change produced by way of the reflexes when corresponding segments, afferent fibers, are stimulated. True osteopathic technique is neither mechanical stimulation nor inhibition of nervous tissue. Release the osteopathic lesion by adjustment and the quiet, permanent and imperceptible stimulation, nervous tension or balance, or tone, will be forthcoming—and this is osteopathy. Specific technique is specific adjustment, wherever indicated, nothing more or less; wherein the rigidity, the immobilization, the subluxation is reduced by mechanical means and nervous balance established. Indiscriminate “stimulation,” “manipulation,” and “general treatment” is almost certain to defeat specific purposes, for in the first place it is not indicated, and secondly reflexes normally intact are disturbed at the expense of the already labored reflexes of the lesion.\*

#### **A FEW GENERAL PRINCIPLES.**

Whatever the character of a nerve stimulus, there is always a chemical and physical change in the environment of the nerve cell. And this change or activity is propagated through the protoplasm of the neuron. Much, therefore, depends upon the integrity of all parts of the nervous element, its functional and structural relations, as well as the basic nutritive supply.

It is interesting to note that the neuron may function for a time without a cell body, but as soon as the nutrition of the protoplasm is utilized, function ceases and the nerve element dies. We must remember two fundamental facts: that an intact nerve cell (structurally) and that both functioning receptive and excitatory cells are absolutely essential to the health of the organism. Associated with this are the facts that “structural differentiation of the cell is correlated with a functional polarity,” and that the process which receives the impulse “corresponds in form and time of development to a cell of the usual form.”

\*See Abrams, “Spondylotherapy,” p. 8.

Another point we should keep clearly in mind is that a nerve element is not an entity. Within all probability every cell and group of cells are dependent to a greater or less extent upon the intactness of the body mechanism. A cell may be termed a structural and functional unit of any organ, but it is the organ or organ-



FIG. 59.—Acute catarrhal inflammation of the intestine (ileum). Hematoxylin and eosin. X 350.

ism complex that is of special specific significance, although every part of the protoplasmic mass is an essential. But it is the functioning en masse that is of particular significance. Thus has arisen the partially true statement that a neuron is independent only from a trophic viewpoint. Osteopathically (readjustment) we are daily taught by the clinical point of view that the various

nervous mechanisms and systems and correlations are specific only within certain limitations; that afferent impulses are essential to functioning; that elasticity, flexibility, mobility, of the skeletal tissues means health, vitality, life; that afferent impulses are not necessarily all sensory ones; that readjustment, not mechanical stimulation and inhibition, is the one essential to osteopathic technique; and that technique is diametrically opposed to any routinism, but is specific mechanical adjustment of minutiae as well as of the grosser tissues.

To the physiologist and pathologist a knowledge of the functional systems is necessary, for the various pathways of the nerve elements are shaped and decided both by the inheritance and experience of the individual. To the practicing osteopath all of this is of importance, but the one essential beyond others is to understand anatomical mechanics and architecture—to practice adjustment.

### **FUNCTIONAL DIVISIONS.\***

We know that all action externally or internally is the result directly or indirectly of stimuli, and that given certain stimuli distinct and characteristic response will follow. This is true of all nervous activity, whether the change relates to the external world or has to do with internal nutritive processes.

Consequently we consider, morphologically, for convenience somatic and visceral divisions, the former dealing with the external surroundings and being divided into afferent and efferent divisions. The latter, being concerned largely with the viscera, is also divided into afferent and efferent divisions.

These divisions, somatic afferent and efferent, visceral afferent and efferent, are fundamental both structurally and functionally, and with exceptions the four kinds of activities, "the reception of somatic stimuli, the direction of somatic movements, the reception of visceral stimuli, the direction of visceral activities," "are called for in all segments of the body, and consequently

---

\*The data in this and the succeeding section has been largely taken from Johnston's "Nervous System of Vertebrates."

each of the functional divisions is represented in each segment of the body, and all the segments of a given division are serially homologous with one another." This is of special interest to the osteopath when considering the importance and significance of the osteopathic lesion to visceral disorder. We know that vasomotor control, visceral muscular tone, and secretory activities constitute an important part of visceral integrity. To what extent the somatic stimuli are contributing factors to these visceral activities and consequently nutrition is of great significance in discussing the relative import of the osteopathic lesion as an etiologic factor.



FIG. 60.—Passive congestion of kidney. Engorged vein and slight cell infiltration. Every animal with lesions from eleventh to thirteenth dorsals presented congested and inflamed kidneys. Urine analysis before and a few days after lesion production supported the osteopathic lesion theory. Hematoxylin and congo red. X 110.



**Somatic Afferent.**—We will sketch a few points bearing upon the several functional divisions. The first division, the somatic afferent, referring to the cutaneous nerves will answer our purpose. These form a large part of the dorsal spinal nerves of the trunk, the section of the body we have experimented with. However, the same principles will be applicable elsewhere as here. These fibers have their ganglion cells in the spinal ganglia. The distal ends are found between the cells of the epidermis and consist of free branches. From the ganglion cells the central fibers pass into the dorsal part of the cord and bifurcate. One branch, the longer, extends upward and the other downward, ending finally in the dorsal horn; these fibers form the dorsal tracts. Each branch gives off collateral branches, some to one side of the cord, others to the opposite side, while still others pass to the ventral horn and to other areas. Thus it is readily seen that there is a basis for a great variety of reflexes, the simplest being with collaterals to the ventral horn.

**Visceral Afferent.**—The visceral afferent division is much smaller than the cutaneous afferent system. These are the fibers that bring impulses from the viscera to the spinal cord and brain. Johnston says: "They are distributed to the mucous surface in much the same way as the general cutaneous fibers of the skin. In the absence of special knowledge as to their appropriate stimuli it may be supposed that the fiber endings are stimulated by pressure as are the general cutaneous endings. Although it would be confusing to apply the term tactile to visceral impulses, it is probable that there is a close analogy between the two. The difference between cutaneous and visceral sensory apparatus is not in the form of the endings or the mode of stimulation, but in the connections of the two kinds of fibers in the central nervous system." The above is of more than ordinary osteopathic interest. If the osteopathic lesion ranks a very important etiologic factor, as we think it does, the relation and connection of the various functional nervous divisions both as to impulses and nutritive supply of is primary and fundamental consideration.





"These visceral afferent fibers form a component of each of the dorsal nerves of trunk." Their ganglion cells are in the posterior spinal ganglia. The white rami conduct the fibers to a sympathetic ganglion and then by way of the sympathetics to the viscus. Clarke's column, which is in a mesial position to the base of the dorsal horn, contains the central endings in the cord. The neurites from the cells of this column constitute the direct cerebellar tract. Some of the fibers of the visceral afferent have other central connections, but the bifurcation and tract formation is not so marked as in somatic afferents. Of course an important relation here is that with the visceromotor reflex.

**Somatic Motor.**—These nerves arise from the cells of the ventral horn. They pass from the ventral surface of the cord and form the anterior fibers of the spinal nerve. The ventral nerve unites with the corresponding dorsal nerve near the distal end of the ganglion of the dorsal nerve and thus is formed the composite spinal nerve. Division of the spinal nerve into dorsal and ventral rami takes place. Near this point the ramus communicans passes to the sympathetic.

The central endings of the somatic nerves are in the latero-ventral area. The cells as well as the dendrites are large and the latter cover a large territory. A number of the neurites pass through one or more segments before making their exit. Somatic motor fibers and their collaterals in the central nervous system are extensive, for bodily movements is an important function. Between the cutaneous surface and somatic motor nuclei there is a direct connection. The connection with these motor nuclei and visceral sensory is not supposed to be so direct; further investigation is required. But the motor neuron includes an important field for stimuli from many sources and bears direct or indirect relation to movements of the body.

**Visceral Efferent.**—The visceral efferent fibers arise from nuclei in the lateral horn and pass out by way of the ventral roots through the white rami into the sympathetic ganglia. Probably visceral afferent collaterals directly connect with the visceral efferent nuclei. The correlation of the somatic and visceral

functions is not understood. There are different tracts and different nerve centers.

The visceral efferents supply the smooth muscles and glands of the body by way of the sympathetics as well as the muscles of the heart and blood vessels.



FIG. 61.—Hemorrhagic inflammation of the kidney tubules. In addition to the hemorrhagic areas beginning cellular degeneration is readily noted. Hematoxylin and eosin. X 110

The great osteopathic lesson to be learned from this brief resume of nervous anatomy is twofold: First, although to a certain extent, both structurally and functionally, the nervous system is partially separated into divisions, there is an absolute dependency of one part to the other to stimuli. These impulses are part of the continuous life of the individual and each division is an absolute essential to every other division, both structurally

and functionally. This is shown by both external and internal environment as well as by the morphological construction. Embryologically the sensory and motor fibers, the glia, the neuroglia, the sheath of Schwann as well as the different nuclei are all interdependent. Impair one portion even functionally and all of the others, to a great or less extent, are impaired.

Secondly, nutritively there is even a greater significance to the point that one part is dependent upon others. Although trophically the neuron is termed an independent structure, still this is a fact only when nutrition is intact and impulses are normal. One of the most important facts of anatomy is to note the grouping of nuclei and the forming of ganglia and to study how absolutely dependent their integrity is to intact circulatory environment. Their circulatory dependency can not be subdivided into parts, more or less independent, as their functions are divided, for a group or ganglion may as a whole be to a greater or less extent impaired by the disturbance of a single vessel. This is a point, we believe, that can not be too greatly emphasized, for its bearing upon osteopathic technique is most significant.

### **THE SYMPATHETIC SYSTEM.**

Embryologically the sympathetic system has the same origin as the cerebrospinal system, which explains the intimate functional and pathological relations between the two systems.

Its development, however, is later than the cerebrospinal system. It is an "outgrowth of fibers from the ventral root and also from the dorsal ganglion, in the direction of the aorta." This continued outgrowth of cells retains its connections until finally corresponding to each segment a pair of ganglia is formed. These are the ganglia of the chain and their connections are the rami communicantes. Later the ganglia are connected longitudinally; also additional ganglia are formed. Thus are formed the pre-vertebral ganglia, and still a little later the cell migration forms the peripheral ganglia, such as the ganglia of the heart and digestive canal. While the above is taking place some of

the cells of the ganglia of the chain and probably of other ganglia "send fibers back along the rami communicantes into the spinal ganglia or the rami of the spinal nerves." These fibers are called the gray ramus communicans. The fibers which grow out from the spinal nerves in time become myelinated and consequently are called white rami communicantes.

Thus the important feature to be noted here is that there is an intimate anatomical connection between the ventral root and dorsal root ganglion outward to the ganglia of the chain, the prevertebral ganglia, such as the cardiac, solar and hypogastric plexuses, and the peripheral ganglia, such as the small ganglia of the heart and Auerbach and Meissner plexuses; and then connection back again to the spinal ganglia or the rami of the spinal nerves by way of the gray rami.

Osteopathically this anatomical relationship is of the greatest significance. It enters into the everyday consideration of the practitioner. Experimentally we have found that all the ganglia, including those of the cord to chain ganglia, are subject to pathologic changes due to the osteopathic lesion.\*

Reference to a few more anatomical relations will probably help to elucidate this problem, although a few of the nervous connections were mentioned in the previous section.

The visceral sensory fibers have their ganglion cells in the spinal ganglia. These "are the largest of the myelinated fibers running in the sympathetic nerves and may be seen to pass through one or more of the sympathetic ganglia without forming any connection with the sympathetic cells." The distribution of the nerves is in the mucosa of the viscera. The central ending is in the visceral sensory column of the cord. Thus it is seen that these fibers are not really a part of the sympathetic owing to their not being anatomically connected. This fact can not have other than an important consideration in explaining etiologically the relation of the osteopathic lesion to visceral disturbances. It is claimed that these fibers "are older than the sympa-

\*Morat, speaking of the general laws of Waller, says: "They may be verified in all nerves, in the tracts found in the spinal column and in the brain and the great sympathetic system." See section, this article, "Changes in Nervous Tissue."

thetic system and that the sympathetic ganglia are placed along the course of these primitive visceral sensory fibers.”

Then there are small myelinated efferent fibers from the cells of the spinal cord that pass out by way of the ventral roots. They enter the ganglia of the chain and end in the first ganglion, or

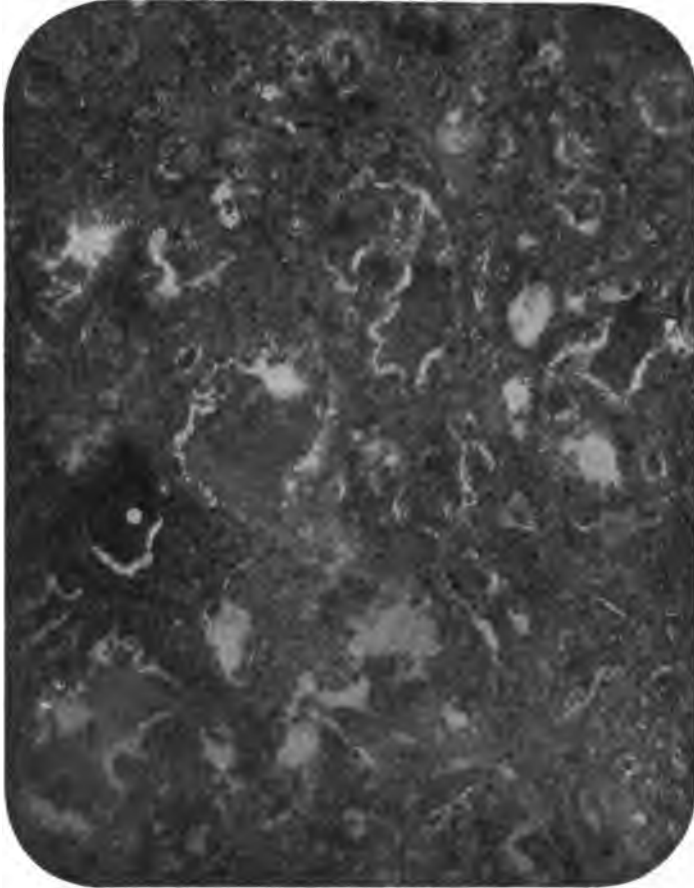

FIG. 62.—Acute parenchymatous goitre produced by the osteopathic lesion. Some of the colloid spaces are nearly normal; others show change from cell proliferation. Hematoxylin and eosin. X 75.



pass through it to another ganglion, or end in a prevertebral ganglion, or a peripheral ganglion. When passing through one ganglion to another they may give off collaterals. These fibers end by piercing the capsule of the sympathetic cells, ganglia of the chain, prevertebral and peripheral and form pericellular baskets; so that "impulses sent out from the central nervous system are transferred to the sympathetic excitatory cells." Thus, probably, "the great majority if not all of the excitatory cells of the sympathetic are thus brought under the direct influence of the central nervous system." Consequently it is readily seen that this type of nerve element of the sympathetic is also an important factor for osteopathic consideration.

Another type of nerve element that goes to make up the structure of the sympathetic system is sympathetic excitatory cells. Their structure has much in common with nervous tissue elsewhere. They may or may not become myelinated, but the fiber is very small. These are fibers that innervate all smooth muscle of the "alimentary canal, the ducts of glands, the urogenital system, blood vessels, the skin or the eye."

The fourth type is the sympathetic sensory cells. These are found in the peripheral ganglia and have long dendrites that "are supposed to be distributed to mucosæ and serve as sensory fibers." They give off branches where they pass through the sympathetic ganglia.

Enough anatomical data has been given to serve our purpose, that "the afferent and efferent neurones whose cell-bodies lie respectively in the cranial or spinal ganglia and in the brain or cord belong properly to the cerebrospinal system and not to the sympathetic," so that "in a strict sense the sympathetic consists solely of the neurones whose cell-bodies lie in the various ganglia, the excitatory and sensory sympathetic cells." Visceral activities is the cause of this off-shoot of the visceral afferent and efferent divisions of the nervous system. The off-shoot is really an interpolation "in the efferent limb of the reflex chain of a peripheral neuron between the cerebrospinal fiber and the organ innervated." There is comparatively little independence, peripheral reflexes,

of the sympathetic system. "The great majority of its actions are directly aroused by efferent impulses coming from the brain or spinal cord and in response to the stimulation of visceral sensory fibers which run through, but have no connection with, the sympathetic ganglia." Hence an important part of the osteopathic lesion pathology must be based upon this last statement. This factor must lie within the findings, pathologically, of the cerebrospinal ganglia. Anything that disturbs their impulses or nutrition must be basic.\*

### IMPORTANT VASCULAR CHANGES.

Within all probability the chronicity of the pathology following the osteopathic lesion is dependent upon nutritive disturbance, first of the nerve cell, and secondly of the vascular tissues. To what extent the mere blockage of local afferent fibers produce serious and long sustained functional disturbance and structural involvement would probably be debatable.† Consequently we are obliged to look for deeper and more significant factors. Although irritation or blockage or disuse of certain afferent fibers must have a deleterious effect, inceptively, upon its dependent reflex arcs, the remaining predominating tissue concerned with metabolic changes is the vascular system. And likewise with the vascular system as with the nervous system the problem

---

\*In this slight sketch we have said nothing about the bulbar autonomic system, the importance of the vagi and glosso-pharyngeals, stellate ganglion, etc., or the sacral autonomic system. Our purpose is to present an outline picture only, of the basic points of osteopathic pathology. We especially refer to Quain's Anatomy, Vol. III, eleventh edition, and Oppenheim's text book, Vol. II, fifth edition.

†Porter in Harvey Lectures, 1906-07, under "Vasomotor Relations," says: "The maladjustment between afferent and efferent impulses is the source of many ills in our modern life." "The vasomotor system seldom if ever dilates or constricts all the vessels at one time. The same afferent impulse will cause the vasomotor center to dilate the vessels of the face while it constricts those of the abdomen. The effect upon the general blood pressure depends upon the relative size of the dilating and constricting areas. Here the splanchnic nerves, which govern the vessels in the abdomen, have great importance." "The more the circulation is studied, the stronger is the conviction that it is not a fixed state, but a sensitive equilibrium, the result of the constantly varying action of a great number of factors." A great clinical fact is constantly presented to the practitioner: There are comparatively few healthy individuals; and the diseased ones present an innumerable variety of osteopathic lesions, which upon an adjustment with a regulation of habits works a wonderful change in the health of the individual. Vessel dilatation must play an important role. Vasomotor spasm and paralysis induced by the osteopathic lesion is certain to lower resistance. Also Morat's "Physiology of the Nervous System," Oppenheim's, "Nervous Diseases," Vol. 1, p. 124; Am. Jour. Phys., Mch., 1911; McConnell, "The Vasomotors," A. O. A. Jour., Mch., 1912.

must be approached from both the anatomic and physiologic sides.

The osteopathic lesion as an initiatory factor is an anatomic condition—a structural perversion—and no matter from just what points or physiologic phases the inception arises, certain definite pathologic changes are noted as a consequence. Just what proportion of this inceptive role the disturbance of afferent impulses play, further physiologic experimentation can alone determine. Consideration of the afferent vasomotor reflex will probably throw considerable light on the problem. But mere anatomic perversion—subluxation, rigidity, etc.—must also, by virtue of its disturbance of anatomic structures injure or damage or disturb circulatory integrity. Nervous tissue is very sensitive to circulatory changes. Mere compression of the abdominal aorta for from fifteen to forty-five minutes will produce temporary paraplegia. If the compression is kept up for an hour or more, permanent paraplegia is the result. The degeneration in these cases is confined to the gray matter and in its connecting tracts, while the spinal ganglion and pyramidal tracts are not affected.

It is the vascular changes of a character approaching inflammatory phenomena—the dilated veins and capillaries, the slowed blood stream, the endothelial compromise, the plasma leakage, leucocytal invasion, and diapedesis—that are of great significance, for when these changes occur in the nervous structures dependent nervous tissue must degenerate. Whether the vascular change is brought about by direct vascular pressure or disturbed afferent impulses by way of vaso-constrictors the significance of the pathology speaks for itself. (And it should always be remembered that nerve tissue has a very rich blood supply.) If the vasomotor centers are automatic only, deep-seated structural perversion affecting the circulation of these centers alone would answer;\* but late physiologies teach that probably the centers are not automatic. (See first foot note under Chapter XLV Practical.) Experiments show that the field of vascular

---

\*See McConnell, "The Vasomotors," *A. O. A. Jour.*, Mch., 1912; "Osteopathy in the Light of Evolution," *A. O. A. Jour.*, May, 1913.

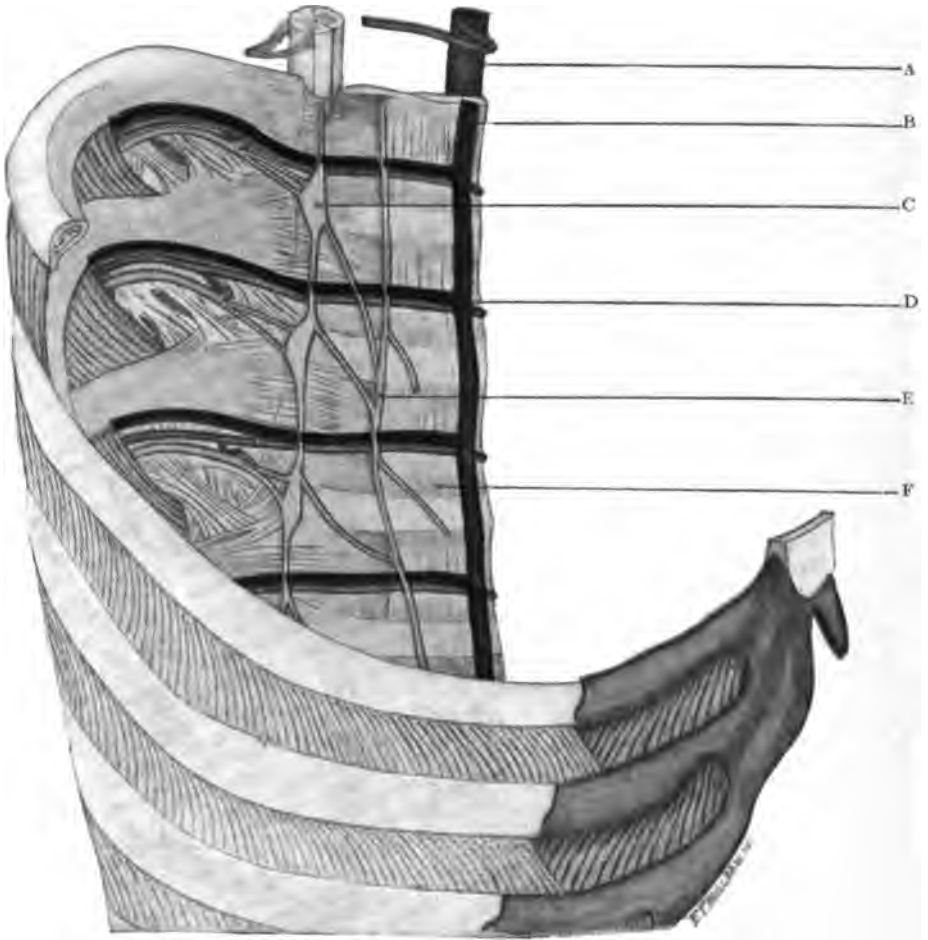

PLATE XXXI.—A, Aorta; B, vena asygos major; C, lateral chain ganglia; D, intercostal vein; E, great splanchnic; F, anterior common ligament.



circulation to the different segments is comparatively extensive and that within all probability the serious or predominating lesion is to the nutritive supply of the ganglia.\*

The above phenomena that approaches the pathology of inflammation is probably basic of many disease changes, whether in nervous tissue or other tissue or viscus, for nervous and vascular structure are both predominating structures. Thus the osteopathic lesion may be both a predominating lesion (lowered resistance) or an active lesion. "Inflammation is the process by means of which cells and serum accumulate about an injurious substance and tend to remove or destroy it;"† but an injury may be mechanical, chemical, thermal, or bacterial. And the injury may show various nervous phenomena and be situated a long way from special influence of nervous centers. But we are of the opinion that the above features are a basic outline explanatory of an important part of osteopathic pathology.

One point further: Although "inflammation is the reaction which follows an injury affecting the walls of blood vessels; increased permeability facilitates the escape of plasma and corpuscles into the surrounding tissue," bacterial infection is not the only cause, for "an immense number of sterile substances, both fluid and solid, soluble and insoluble, organic and inorganic, incite a reaction which differs in no essential respect from that which follows the invasion of micro-organisms."‡ This would seem to teach us that a fundamental law of nervous physiology is that a nervous equilibrium represents a fluctuating vasomotor balance dependent upon either, or both, afferent tone and nerve-cell nutritive integrity. Muscular contracture, spinal rigidity, vertebral subluxations, a displaced viscus, or a foreign body effect fundamentally nervous tissue and vascular structure after

---

\*"The arteries in the brain and spinal cord are end-arteries; that is, are vessels whose branches do not anastomose with those of neighboring arteries, but break up into capillaries continued in the veins. Martin's General Path. See also Oppenheim.

†Opie-Harvey Lecture on Inflammation, Feb., 1910. See also Martin, Gen. Path.; Tloma, Gen. Path. The nervous system we have taken for granted may be disturbed by other causes than osteopathic, e. g., heredity, infection, auto-intoxication; but in these the osteopathic lesion is undoubtedly often a factor.

‡Opie-Harvey Lecture, 1910.

the same manner. Local congestion of any part of the body produces phenomena basically of the same character. But the locality of the lesion may be most significant, e. g., the spinal osteopathic lesion being contiguous and in fact not only environing but dynamically penetrating most important structures. Thus must not only engorgement, ischemia, altered blood state and various tissue changes play their role. Likewise adhesions, contractures, and various stages of chronicity play a subsidiary role to a vertebral lesion. The locality and character of the gross anatomic change to the finer and far-reaching histologic disturbances are innumerable.\*

### CHANGES IN NERVOUS TISSUE.

One of the most significant phases of osteopathic pathology is to be found in disturbed vascular supply to the nervous tissue.† Judging by our experimental findings (microscopical), the nutritive changes in the ganglia must be paramount. Starting from the ever constant fact that nervous tissue is unusually well supplied with nutritive vessels, any change in these vessels would seem significant. And these changes, dilatation, serum leakage, etc., have been repeatedly noted. The ganglia from cord to sympathetic are unquestionably affected.

The ecchymoses, diapedesis, cellular atrophy, and neuron degeneration can have but one interpretation, especially when concomitant with, and anatomically related to, the perverted tissue (osteopathic lesion) and concurrent visceral functions are disturbed, that the osteopathic lesion is a vital part of etiology.

The restriction of a blood current to a part is of primary importance and particularly so when nervous tissue is concerned. Morat speaks of three orders of nervous degeneration, Wallerian, ascending, and atrophic. Osteopathically, we believe, it is the

---

\*But in all the maze of histologic, physiologic and pathologic data, we must not lose sight of fundamentals, for if the osteopathic lesion does not fill an important gap in etiology or phenomena basic to perverted physiology the osteopathic lesion is comparatively an insignificant factor.

†Research Bulletin No. 1, "The Osteopathic Lesion."

atrophic order of degeneration that invites special consideration; not necessarily "through prolonged default of functional activity," but through definite and active pathological changes dependent upon vascular disturbance. This reveals to a certain extent a new pathology, not that "a vascular dilatation followed by diapedesis and leucocytal invasion" is a newly discovered condition to an extensive pathology, but we believe this is a "new pathology" as interpretation in so far as study of the osteopathic lesion has revealed.

That there is a certain basis for this pathology, other than osteopathic, medical literature shows. We would refer to Oppenheim, Vol. I, pp. 109, 269, 395; Vol. II, pp. 1163, 1172. He also cites an interesting point, p. 1313: "It has been long since shown by clinical observations that a disturbance of vasomotor innervation leads in the end to degenerative changes in the vessel walls."\*

### SUMMARY.

Two or three features of the nervous system, broadly stated are fundamental to an understanding of the osteopathic lesion:

(a) Co-ordination of the innumerable activities dependent upon both external and internal environment. Internal bodily activities initiate changes as well as external activities, and conduction and co-ordination of these impulses constitute the "biological significance of the nervous system." Osteopathically, the structural and functional unification of the different segments constitutes the anatomical and physiological basis of the lesion;

(b) There are various kinds of "sensory" stimuli, whether from external or internal sources. The several afferent fibers are simply limited to the character of stimulus necessary to initiate an impulse. A structurally intact fiber is the first essential to health, while a constantly functioning fiber in response to its

---

\*For supplementary reading consult Bevan Lewis in Allbutt System of Med.; Meigs, "Origin of Disease;" MacKenzie, "Symptoms and their Interpretation;" Research Bulletin No. 1.

An interesting series of articles by Solis-Cohen bearing on angio-neurotic conditions will be found, "N. Y. Med. Jour.," Feb. 19, 26 and Mch. 5, 1910. Angio paralysis and angio spasm are undoubtedly an important part of pathology.



characteristics, whether from immediate or reflex sources, completes its purpose. We should not lose sight of the fact that all nervous phenomena from special functioning to bodily tone are unequivocally dependent upon the so-termed reflex changes. Keeping in view the basic point that all nervous response is absolutely dependent upon the afferent fiber, reflex arc, and efferent fiber, will be most valuable when discussing nervous structures more or less arbitrarily "specialized" and "differentiated";

(c) "The superiority of the nervous system of man does not consist, in the main, of superiority in sense organs or motor apparatus, but in the enormous development of the intermediate neuron system." (Some of our data here is derived from Bailey and Miller's Embryology.)

These intermediate or central neurones mediate between the afferent and efferent neurones. This increases the complexity of the nervous system by associating all kinds of stimuli, adding complicated combinations and extensive co-ordination. There is a vast difference in the complexity of a two-neuron reflex arc and a three-neuron reflex arc. In the human brain the special distinguishing feature is the association neurones. Thus evolutionary change is not so much a segmental one as it is a development of the associating mechanism. An important consideration here is that data derived from animal experimentation is reliable and applicable to all vertebrate nervous systems.

A striking and significant point in the highly developed nervous structure is the concentration, centralization, and fusion of the nervous tissues by increase of ganglionic structure and association fibers. This is early initiated in the embryo by the formation and closure of the neural tube. Among other changes in the morphology of the afferent and efferent neurones, there is brought about a certain physiological dependence of the internal (visceral) and external (somatic) structures, although the inter-  
polation of neurones in the autonomic system represents a certain independence. However, the cord sends efferent fibers to both somatic and visceral structures, and within all probability the integrity of a segment is dependent upon all incoming stimuli of its own as well as contiguous segments. There may be a certain

amount of physiological dependence, still the intersegmental neurones are an essential to group and higher functioning.

In the osteopathic lesion (pathology) we should keep in mind the fact that the changes are more segmental in character rather than always showing a very definitely localized point of obstruction. Reflex activity is the basis of physiologic functioning, and the several segments are in reality a series of reflex arcs. Whether inceptive pathologic changes are, like the vertebral osteopathic lesion, contiguous to the central nervous systems, or are brought about by a duodenal ulcer or adherent appendix, the nervous involvement is expressed through the reflex arc. No matter how specialized the nervous structures may be, there is basically a dependent reflex change as well as a greater or less widespread disturbance of nervous equilibrium.

Nervous equilibrium is not alone a localized phenomenon, but instead a generalized one, as expressed, for example, in the nutrition, tone, and neuro-muscular balance being dependent in its greatest efficiency upon all afferent fibers, reflex arcs and efferent fibers. Even the innervation of a single skeletal muscle comes from more than one segment or the intestinal motors may be blocked from more than one point by either central or peripheral lesions. Normal impulses, free circulation (arterial, venous, lymphatic), and sufficient oxygen are fundamental to metabolism.

Embryology, histology, physiology, pathology, and experiment have all contributed to a partial understanding of function and perverted function, but the greatest of pathological results medically have been a noting of effects and not of causes, in so far as the innumerable disorders and their infinite gradations are concerned.

Nervous and vascular tissues are master tissues, hence, logically we must look to these tissues, for the inceptions of bodily ill health. Fundamentally, anything that impairs these tissues will be reflected upon their dependent parts, and the importance, physiologically, of the tissue or organ involved (e. g., kidney) will further determine the character and gravity of the secondary changes. Here, however, we are specially interested in the inception and immediate effect of the osteopathic lesion.

**EQUILIBRIUM AND HEALTH.**

Before one discusses the nature of ill health, some sort of health standard should be instituted. Health from the standpoint of nervous functioning is dependent upon a stable equilibrium; this means not only uninterrupted nervous conduction, but sufficient nervous impulses. Likewise, in vascular functioning, the flow must not only be unimpeded, but it must be sufficient and continuous. In other words, physiologic equalization is the fundamental requirement.

Probably neither physiologists nor clinicians have sufficiently emphasized the necessity of the afferent impulses, whether so-called "sensory" or others, that constitute the basis of all nervous activity. Every movement, exercise, work, recreation, air currents, respiration, alimentary activity, vascular propulsion, bathing, environment, has its effect upon afferent innervation, in fact, is basic to so-termed hygiene.

The principle of the summation of stimuli is well exemplified here, and constitutes a fundamental principle of bodily health and development. (And it also constitutes an important part of pathology.) The effectors must function continually and regularly in order that the receptors may execute their part. In order that the body may work as a concatenated whole, every part must fulfil its requirements. Herein, in our opinion, is the basic point to osteopathy. Given an osteopathic lesion, whether osseous, muscular, or visceral, the first effect is one of nervous blockage. The activity, impulses, and rhythm of the local forces are at once disturbed so that both local and correlated tissues are impaired, dependent upon their character and specific functions. A twisted vertebra, rib, or innominate will have no different effect, basically, as has been stated, than an adherent retroverted uterus, a fibroid degeneration of the appendix, or a broken plantar arch although the location and relation of the vertebra to the central nervous system are of vastly greater impeding significance.

**ANATOMIC AND PATHOLOGIC CHANGES.**

Anatomical perfection (structurally) is the basis of health from a characteristic osteopathic viewpoint, for this implies perfect nervous and vascular functioning, provided hygienic measures are carried out (although upon a broad biological basis function precedes structure, and practically physiologic activity and mobility is the health criterion). It would be beside the point, as we view it, to always look upon the osteopathic lesion as some specific or individualized lesion of the nervous system alone, as for example, degeneration of the posterior column in tabes dorsalis, or degeneration of the pyramidal tracts in early acquired spastic paralysis, yet this is the viewpoint of many when they insist (without any verified observation) that the pathology of the lesion follows pressure of the fibers at the spinal-foramen exit. If this were the case the pathology of the lesion would be a comparatively simple matter. No one will question but that such a condition may occasionally be found, or that very serious consequences may not follow, but we believe that the field is fundamentally a much broader one.

Although the ligaments to a large extent maintain the chronic lesion (anatomically) it is the circulatory derangement, impoverished nutrition, that maintains the pathologic changes. Whether part or all of the vascular pathology inceptively is due to segmental strain or stress *en masse*, or the result in part or as a whole of nervous blockage, resultant anemia, or hyperemia followed by edema and anemia of cord centers, sympathetic ganglia, and viscera are within all probability dependent upon nervous phenomena. Thus, taking the vertebral maladjustment as a type of an osteopathic lesion, the inceptive effect is a functional derangement in part, of the corresponding nervous segment. Upon a nervous basis alone, this is followed by either inhibition or stimulation (probably the latter at first), of involved nervous tissues. These functional derangements, if continued, are followed by organic changes.

Organic change implies first a lessening of the nutritive intactness of the nervous element, either to lack of normal stimulus or traumatic damage, or to stress (mechanical) upon blood vessel or lymph channel; or, of probably greatest importance, upon involvement of vasomotors.\* Following this further involvement and complication may arise, (a) infection, (b) toxins, (c) chemical changes, due to the lowered resistance.

The location of the vertebral lesion is what makes the mal-adjustment significant. The central nervous system, more than any other tissue, is less resistant to circulatory impoverishment. Then general fatigue is an additional common factor frequently overlooked by the physician. A physiologic unit will be maintained so long as the system is sufficiently energized, even if certain slight pathologic conditions are present. Forces that sustain one in health and ill health are largely of the same character, but vary greatly in degree as gradations of health conditions are initiated.

---

\*Relative to the theory of trophic nerves an instructive series of experiments will be found in the *Am. Jour. of Physiology*, Sept. 1, 1910, "The Rate of Healing of Wounds in Denervated Skin Areas and its Bearing on the Theory of Trophic Nerves," by Clara Jacobson with an addendum by Prof. Carlson. Among the conclusions are the following: "The results of the experiments reported indicate no diminution in the rate of healing of wounds in a denervated (sensory and motor) skin area as compared directly with that in a normal area." "It seems that so-called trophic disturbances may be due to vasomotor changes with increased susceptibility to infection or to the loss of protective reflexes from loss of sensitivity to injurious agents." Prof. Carlson adds: "I fail to see the possibility of this distinction (referring to Tschermak that there is no evidence for the existence of separate or specific trophic nerve fibers, but consider it highly probable that motor and sensory as well as afferent nerve fibers convey trophic impulses as an accessory function) between motor-sensory-tonic and trophic impulses in the same axis cylinder on the basis of our present knowledge or the advisability of retaining the term trophic for this conception. It seems to be true, in general, that moderate amounts of the special activity of organs are favorable to their metabolism and growth. The impaired metabolism and consequent atrophy in muscle, glands, and nerve centers following lesion of motor, secretory, and afferent pathways respectively can therefore be wholly accounted for as a direct result of the cessation of the special organ activity." "The changes in muscle, gland, and nerve cells in consequence of lesion of or altered activity of conduction paths are probably the result of disuse or altered special organ activity. And the so-called trophic changes in the skin and epidermal structure can be accounted for by altered activity of the capillary cells in consequence of the hyperemia, increased pressure and possibly interference with secretory fibers."

## CHAPTER XLV.

### PRACTICAL CONSIDERATIONS.

Adjustment is the magic coat of osteopathy. The condition of being adjusted is the essential quality that masters the secret forces of nature so that wholeness of the body is attained and maintained. To adjust is a law, for it represents a definite relation between facts. And the clothing of the body with the law represents one of the fundamental factors of biology.

Correction of the lesion, to adjust, is an accomplishment that requires considerable observation, experience, and practice. The art can not be learned in a day. Many factors, anatomic, physiologic, and pathologic details, as well as judgment, enter into consideration. Basically the perceptive faculties have to be creatively changed in order to not only recognize the lesion but to interpret it; and this requires much time and conscious effort. As Poincare has emphasized in one of his books, "so-called correct perception is connected with a long-continued process of perceptual education, motivated and initiated from within." And this is just what the student so rarely appreciates. He is not willing to spend the time and effort and actual labor necessary to perfect himself, and the result is mediocre ability. He too often wilfully fudges the issue with a lot of hodge-podge methods at the expense of clean-cut therapy, and naturally the result is disappointing.

Havelock Ellis wrote the following in reference to a certain scientific method. We quote it because it is so apropos to the method of osteopathic adjustment: "A scientific method is, strictly, an instrument. Its value depends upon the user." In adjustment we have an "instrument of great precision, but the best instrument in the world will not enable a man to select his facts rightly or to interpret them correctly." Here is exactly

the test-point in practical osteopathy—selection and interpretation of facts. It is not only individual variation in every case and lack of experience that may prevent an accomplishment of desired and possible results, but after certain and sufficient data is secured the interpretation may be absolutely wrong. Then in addition to all this there is the art dependent upon tactile education, precision and co-ordination, that when perfected is the acme of the technician's ambition. To him this is the means to the end of the joy of living; as Stevenson said, "to miss the joy is to miss all."

Structure and function are most intimately inter-related. We believe that evolutionarily function precedes structure. Take, for example, natural selection, a factor of evolution, adaptation of structure is the principal fact or reality gained by the organism. The striving and expressing of function results in both changed and added structure. This, in our opinion, is of great biological significance. But in the field of disease where a very complex organism is structurally deranged the relationship between structure and function is different; for here the osteopath comes to the aid of an organism that is either deranged structurally so that functional processes are impaired; or he harmonizes the environment to the individual and short-circuits the process of evolution or reduces its effects to a minimum, so that the weakest has a greater chance to survive; or on the other hand he frequently harmonizes the individual to the environment,\* as when he regulates the patient's daily regimen. Thus in the practical work of the healing art we consider structural integrity as basic, for we are dealing with problems of the moment and with the body as we find it, and not as the forces of applied eugenics and heredity may improve future generations. Our work is one of expediency. Although the functional test is the important one, structure must

---

\*We should appreciate that environment includes a very wide field (see Henderson, "The Fitness of the Environment"). "It is possible that the neurones possess some automatic power, i. e., some power of initiating nervous processes, as a result of changes in the fluids surrounding them. This automaticity, however, is not a prominent feature of the nervous system, which has been evolved as a purely reactive mechanism to the afferent impulses resulting from the material changes continually taking place in the environment of the animal." (Starling, "Human Physiology.") See also, Sherrington, "The Integrative Action of the Nervous System."

be intact before it can find complete expression or function. Herein, then, arises the practical point in osteopathy—integrity of structure.

We unhesitatingly place the so-called bony lesion as the prime consideration in characteristic osteopathic technique, for integrity of structure demands it. Morphologically and technically the connective tissue constitutes the structural basis, for both configuration of the organs as well as the body as a whole are conformed thereby, but later development chemically changes the density of the bones so that veritably they become the actual foundation of the mechanism.

- Intimately inter-related and associated with the bony structure are the muscles and ligaments. The former are a fairly stable but at the same time a quivering mass of organs that give form and shape and support and litheness to the body, that brings about balance and stableness of the mechanism, and that furnishes motive power and leverages for the several segments and members and the organism as a whole. Their structural and functional integrity is of the greatest importance in not only maintaining health, but are essential to the growth and development. We can not divorce one part of the structure without impairing or taking away something from another part or from the entire mechanism. It is the aggregate of structure and function and their concatenation that makes the individual. In other words every part must be intact and every function exercised before wholeness is attained.

Associated with the bones and muscles and ligaments are the viscera which may be structurally deranged and misplaced and as a consequence create a train of symptoms that from an etiological viewpoint come under the category of the osteopathic lesion. Specialization of cell and organ has not altered the underlying principle of adjustment (indeed, it has called for more precise attention), but has simply added to the complexity and intricacy of the organism. Exercise of function is the open sesame that unlocks the magic door of potentiality so that the forces of growth, development, and repair find expression. The comple-



ment of function from the angle of osteopathic technique is precise adjustment of the anatomical parts in order to allow the necessary freedom of the forces.

The practical interpretation of the lesion must not be construed as a peripheral blockage *per se* whether the periphery so far as the nervous system is concerned communicates with skeletal tissues, the digestive, pelvic, or respiratory apparati, or some other part, but in addition the blockage has a far-reaching and deep-seated effect, other than so-called nervous reflex, to the dependent metabolic processes, especially the ganglia of the central nervous system. If the factors that create and establish tone are dependent upon external, peripheral stimuli, and which stimuli may be applied even to abstract and non-spatial dealings of the mind,\* the physiologic interpretation of the lesion is only a perversion of those processes due to an alteration of the circumstances that normally contribute to establish tone; and clinical experience and experiment prove this to be the case. This is the practical significance and importance of the osteopathic lesion, and the niche it occupies in the etiologic field is far from a small one.

### **OSTEOPATHIC CENTERS AND SPECIFIC TREATMENT.**

Probably considerable confusion and misunderstanding has arisen in our technique due to the association of the terms "osteopathic centers" and "specific treatment." "Osteopathic centers" has always been more or less a hazy term, based largely upon the location or rather aggregation of the so-called visceromotor, secretory, and subsidiary vasomotor centers in the spinal cord, implying that by so-termed stimulation or inhibition or manipulation of certain spinal areas definite effects upon the viscera will be forthcoming. This idea, we think, has led to a misinterpretation of the so-called specific treatment or manipulation. Hence has followed with a number of osteopaths technique that is far from osteopathy and is nothing more or less than a "movement cure."

\*J. S. Huxley, "The Individual in the Animal Kingdom."

Osteopathic centers are nervous centers. An interpretation of the latter term will clear up the former. Centers are nothing more nor less than an association and collection of neurones into a partial system in order to carry out certain systematic functions.\* Thus there is both an anatomical and functional relationship and the aggregation of the gray matter is the greater when the demands are more complex or of a higher order. This co-ordination of functions really means functional or nervous centers not trophic. Embryology teaches us that there is a fusion of the segments of the gray axis giving origin to the functional association. But the segments are neither entirely independent morphologically or functionally. Even a slight acquaintance of the relation of embryology to the closely interrelated spinal cord and brain segments to the sympathetic shows this most clearly. And a study of the osteopathic lesion embryologically considered, as well as a study of the experimental lesion, still further accentuates this fact. Hence the basis of the nervous system being made up of an aggregation of units of more or less common and definite functions, but the functions of the several partial definite systems being graduated into others and all together comprising an independent whole.

So far as locality is concerned, treatment can be "specific" to a certain point only—in just so far as one of these functional units when disturbed by a certain lesion has its certain specific functions impaired, for an account of the dependency of these functional units one to the other the equilibrium of the entire system is disturbed. Now, owing to the probable general disturbance, to a greater or less extent, "specific" treatment does not necessarily imply the other extreme, a general body manipulation. This latter, alone, may defeat the entire purpose of the treatment; at any rate it precludes any definite osteopathic diagnosis.

Specific treatment means specific adjustment—this is funda-

---

\*Morat states, "The connections which the different portions of the neuron gather together are centered in the nerve cell, whence the name 'trophic center' is given to the latter. In their turn the neurones associate and collect themselves together in more or less independent system, in 'functional centers' (or nervous, properly so-called)." See, also, Johnston, "Nervous System of Vertebrates."

mental to osteopathic technique. Without specific adjustment osteopathic etiology and pathology amounts to but little to the practitioner. Although the characterization and significance of osteopathy is based upon our interpretation of etiology, to the practitioner it amounts to but little if specific adjustment is not accomplished. Consequently specific treatment is not treatment of "osteopathic centers" whether by so-termed "stimulation," "inhibition," or "manipulation"; neither is it a "movement cure," "routinism" or "medical gymnastics." Specific treatment can mean nothing more nor less than specific readjustment of the osteopathic lesion;—and we know the osteopathic lesion is "any structural perversion which by pressure produces and maintains functional disturbances." Definite mechanical principles must be followed according to the individual case. This is characteristic treatment; and it requires most painstaking effort, for every case presents new problems to solve.

All of this, however, does not preclude a certain amount of muscle relaxing or muscle toning or prescription of exercise or other hygienic measures. Lesions naturally vary in character and extent and present varying factors. From the very frequent vertebral rotation to the extended rigid area a great variety of structural perversions may be found. But it is the definite adjustment of part to part, and of part to whole with a minimum of shock, and knowing when it is done, that characterizes the treatment.

### **THE TWO FUNDAMENTALS.**

In our study of the osteopathic lesion, both clinically and experimentally, we are thoroughly convinced there are two fundamentals that must be observed in order to secure a maximum of success in treatment:

First, the bodily mechanism should be basically intact before further adjustment or correction is attempted. By this we mean the spinal column base (pelvis) should be structurally normal. Every mechanism should be "leveled up" before one can expect the superstructure to assume a relationship with a minimum of

friction or before one can hope to adjust the "boxes" with any degree of success; and it is not straining a point in the least (to the contrary, it is most practical) to say that with the human machine the relationship of sacrum and innominata (aside from the consideration of a possible "broken" plantar arch) must be "leveled up" or adjusted. This, then, gives us a foundation upon which to adjust the superimposed parts. Dr. Still has repeatedly urged us in our technique to commence at the bottom and seriatim "line up" the lesions above. Many lesions are compensatory or secondary to some lesion lower down in the structure, and will not yield or stay adjusted until the basic lesion is corrected;

Second, a fundamental point in technique is specific adjustment. It is not enough to know where the lesion is, but we must know just how it is displaced. Most lesions are due to some form of rotation, and if we can analyze its characteristics it is then simply a matter of releasing the articular processes and negotiating the return by the characteristics presented.

We know this sounds easier than it really is. But, fundamentally, a lesion in nearly every instance is a rotation, and if we would spend much more time on diagnosis and far less on hit or miss technique, with a little mechanical ingenuity, our therapeutic efficiency would, at the very least, be doubled. The technique should be a comparatively easy matter; it is the diagnosis that is difficult. There are many features that should be considered. Aside from the mere mechanical problems there are the various local and general pathological conditions, strength and age of patient, etc.

There is one other point, however, which should almost be dignified to a position as fundamental. It is a corollary of the above two fundamentals; it is to locate the "key" to a series of lesions, a curvature, a rigid area, or what is not infrequent, a distant lesion. To illustrate: A cervical lesion may be secondary to a dorsal twist, or rigid area to a lumbar or innominate deviation; in fact, there are innumerable gradations and combinations. Herein lies the really difficult work.

In contrast to the above there are two things adjustment technique is not:

First, treatment of "osteopathic centers." There is no such thing as specific treatment of centers (as we have emphasized), as some of us may be led to believe; but there is most decidedly such a thing as specific treatment of osteopathic lesions, and this may be respective or irrespective of centers. A center is nothing more or less than a physiological grouping of neurones (as heretofore stated) for the special purpose of accomplishing some special act; for example, of contracting the walls of the stomach. It is not confined to a segment alone, but the co-ordination includes two or three or more segments. Naturally a lesion within an area of say four or five segments will affect the innervation of a viscus through vasomotor, visceromotor or secretory fibers. The specific features of the lesion arise not so much with the matter of regional location as with the matter of maladjustment, and our ability to adjust with a minimum of exertion. "A nutritional center" is simply the nucleus of the neuron;

The second point of what "not to do" is muscle kneading and stretching. Not but what this has a place and is good secondary treatment, but it must not be confused with the infinitely more essential and characteristic feature of specific adjustment. Many a refractory, contracted, or rigid area will yield in no other way than by adjusting some local or distant lesion.

Lesions are very apt to occur in the anatomical weak points (where there is a "break in the continuity of structure"), and where habitual strain and stress is greatest, although not by any means confined to those areas, such as the innominata, fifth lumbar, lower dorsal, upper dorsal, atlas, etc. Then in addition to the above, the relationship of a joint should be considered from both the static and functional viewpoints. An abnormal static position may locate the key to the lesion while the functional relationship will readily supply the key to executing the technique.

To sum up: In our opinion, the study of practical technique should be more elemental. There has been too much confusing and clouding of the essentials by the various phases of general

treatment, gymnastics, exercises, massage, stimulation, inhibition, osteopathic centers, and the like. Not that all these things are to be classed as "anatomy musing"—time-killing stunts, but that they are utilized too often by those who really know better, as well as by the careless and inefficient, as osteopathic scape-goats. Consequently, a little of definitely applied mechanics with judicious attention to hygiene, diet, and corrective exercises, will approach Dr. Still's conception and success.

## CHAPTER XLVI.

### THE PRACTICAL APPLICATION.

It would carry us beyond the confines and purposes of this article to outline the technique of the lesion. It has been our special scope to sketch the physiologic relation and importance of the same and its wide application in the etiologic field. We have emphasized that it is the etiologic concept of disease that characterizes the science of osteopathy. The art, the technique, is only a means to an end. However, of course, the means to an end is no small part of a school of the healing art, for upon the successful interpretation and application of a therapeutic measure does health or ill-health, or life or death, depend.

After a student has become thoroughly imbued with the osteopathic concept, it is then a matter of study and observation and practice and experience before he can hope to become a fair technician. He must possess or acquire a certain mechanical aptitude, a well-educated sense of touch, and a thorough appreciation that every case presents a distinct individuality. Although basic principles remain the same, the application is always different. There is no formula or rule of thumb to follow; this seems to be one of the most difficult things for the novice to thoroughly appreciate. Then in conjunction with the problems of technique arise those comprised in the fields of hygiene, sanitation, dietetics, surgery, toxicology, etc.

On broad lines the field of practice includes prevention, cure, and palliation. Physiologic functioning is the great desideratum, based upon the fundamental biologic principle that function precedes structure; this constitutes the great field of the future as exemplified in the growing child wherein growth, development, and plasticity of tissue are prominent features, and thereby nu-

trition, exercise of function, education, and integrity of structural relations are the means to the end. But upon the other hand the converse of this great principle, function precedes structure, is also true, and that is structure determines function, provided we remember that we are dealing with the individual whose structures are either predetermined or in the adult have already attained completeness.\* Herein, then, arises the immediate value of osteopathic adjustment and the significance of the principle to the physiologic unit, for normal structuralization is the basis of health from the standpoints of expediency and future normalization. This is the sound basis upon which technique rests, which of course must be tempered by good judgment as pathology, age of patient, environment, habits, etc., suggest.

The physical make-up of an individual as shown by conformation, configuration, relation of segments, poise, and equilibrium is naturally influenced by the ever constant force of gravity. There is always a constant and definite relationship between the structural lesion effects and the line of gravity. The interplay between the osteopathic lesion and the gravity line is as distinctive as between the pull of gravity and the different segments of the body. The relative proportions, or ratio, as exemplified by weight of head, torso, abdomen, pelvis and limbs, the mensural ratio as well, and the mobility, flexibility, and resiliency of tissue as shown by posture and poise, are all factors of the utmost practical importance in this inter-relationship between the line of gravity and the osteopathic lesion. Compensation and adaptation upon the structural plane is but another way of expressing this relationship.

Taking the vertebral lesion as a type it is not structural deviation alone that characterizes the same, but in addition there are other factors that determine the pathognomonic validity of the lesion, viz., restricted movement, contracted muscles, tenderness, lessened vital response, variation in temperature, and disturbance of function.† These, or the majority of them, will be present whether the lesion involves a vertebra, rib, innominatum,

\*See McConnell, "Osteopathy in the Light of Evolution," A. O. A. Jour., May, 1913.

†The most important of these is restriction of movement, for the function of a joint is motion.



viscus, plantar arch, or any tissue or organ. With the vertebral lesion of a chronic nature the damaged articular ligament is the tissue that maintains the structural perversion; in the acute lesion it may rest with the muscles. From this arises a pathology due to nutritional changes in the nerve centers and from thence the neuron and its subsidiaries and collaterals initiate a more or less widespread involvement depending upon locality, severity, resistance, fatigue, and various contributing factors.

The *modus operandi* for correction depends upon a measure that has for its purpose a release of the constraining tissues. Take the vertebral lesion: the application of a mechanical force that will precisely and definitely loosen the articular ligaments, whether it is by means of "exaggerate-the-lesion" principle, or approximating the contiguous spinal segments so that all related tissues are more or less released, matters but little, provided the adjustment is specific and the resultant shock negligible. For the extensive field of technique the student is referred to the various works and articles that treat of this work. There is one point in practical osteopathy that is too frequently neglected and that is the effect of reflex irritation upon the spinal lesion. The lesion may be of such disturbing character as to produce a severe visceral involvement, e. g., of the digestive tract, and in turn the reflex upon the vertebral muscles embracing the lesion is added to that of the vertebral lesion. It may be impossible to adjust the lesion until the organic disturbance somewhat subsides through palliative and preliminary treatment of the lesion or dietetic measures that lessen the reflex effect, whence it will be comparatively easy to adjust the vertebræ.

In conclusion we wish to add that above everything else technique is specific work. Every case is a law unto itself. There has always been too much of the "routine habit" in vogue instead of clean-cut therapy. Dr. Charles C. Teall has well said: "If every osteopathic physician would analyze each movement in a treatment—what is needed, why it is given, and what it will accomplish, he would find that half his effort was unnecessary and it would make his work specific as well as compel a knowledge of conditions."

# SECTION X

---

RESEARCHES OF DR. BURNS  
AND DR. WHITING



# RESULTS OF OSTEOPATHIC RESEARCH.

BY LOUISA BURNS, M. S., D. O., D. Sc. O.,  
Professor of Physiology, The Pacific College of Osteopathy.

---

## CHAPTER XLVII.

### THE BLOOD CELLS.

In these studies of the development of the blood cells, and of the manner in which they are affected by abnormal conditions, the technique described by Emerson and used by his classes in the laboratories at Johns Hopkins, has been employed.

The usual examinations made of the blood include: 1. The estimation of the hemoglobin; 2. The actual count of the erythrocytes; 3. The actual count of the leucocytes; 4. The differential count of the leucocytes.

The hemoglobin is determined by means of Dare's hemoglobinometer. This is a very convenient instrument; its only handicap lies in the fact that it is not always exactly accurate. The Meischer modification of von Fleischel's hemoglobinometer is much more nearly exactly accurate, but it is clumsy to use and a great deal of time is needed both for the testing of the blood and for cleaning the apparatus afterwards.

In the studies here reported the von Fleischel instrument has been employed to check up the Dare's hemoglobinometer, and the Dare's then used for the determination of the hemoglobin in most cases.

The actual counting of the red and white cells was done by means of the Thoma-Zeiss apparatus. The counting chamber with Turck ruling was found most convenient. The blood was

diluted two hundred times with Toisson's fluid, both for the erythrocytes and the leucocytes. After mixing the blood by shaking for two minutes and discarding the first four drops of the solution, the counting chamber was filled in such a manner as to prevent any bubbles of air being found under the cover. The drop was large enough to flow into the moat slightly, but not to flow over the square of glass which supports the cover glass. The pressure made upon the cover glass was usually sufficient to cause the appearance of the rainbow colors. Sometimes the glass was not sufficiently perfectly ground to permit this appearance.

The erythrocytes were counted in fifty of the small squares on the counting chamber and the leucocytes over the entire field, that is, of thirty-six hundred small squares. The counting chamber was then washed and dried, and a second drop prepared and counted in the same manner. A third drop was prepared in the same manner, but no red cells were counted, and only the leucocytes in eight hundred small squares were counted. This makes a count of the erythrocytes in one hundred small squares, including two drops of solution; the leucocytes in eight thousand small squares, including three drops of the solution. Since each small square includes one four-thousandth part of a cubic millimeter, and since the blood has been diluted two hundred times, it is evident that the number of small squares found in one hundred small squares, multiplied by eight thousand, must give the number of erythrocytes in each cubic millimeter of blood. In like manner the number of leucocytes found in eight thousand small squares, multiplied by one hundred, must give the actual number of leucocytes in each cubic millimeter of blood.

The differential count of the leucocytes was made for the purpose of determining the relative numbers of the different classes of leucocytes in the blood. This determination cannot be made by the use of the counting chamber, partly because the chamber is too deep to permit a sufficiently high power of the microscope to be used, and partly because the rarity of certain

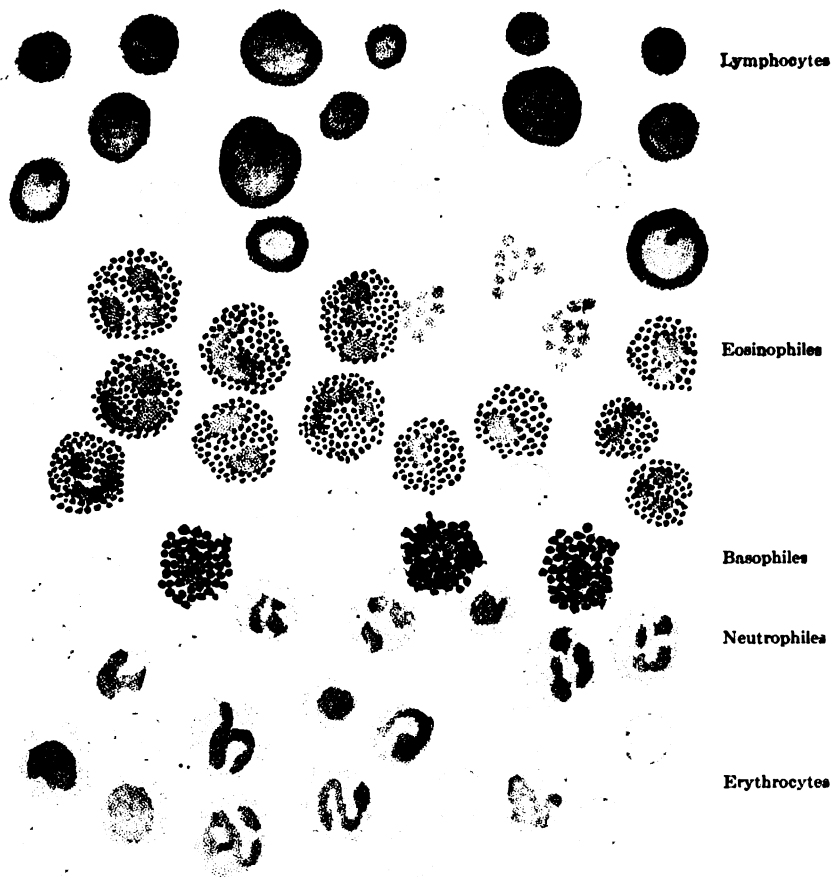

PLATE XXXIII.—LEUCOCYTES.



forms would necessitate the counting of an enormous number of chambers in order to secure anything like accurate results.

For the differential count, thin smears of the blood were made upon ordinary cover glasses. These were dried in the air and stained. Wright's stain, eosinate of methylene blue, was used in all cases included in this report. This was made with slightly varying technique, but the essential principle is the same—the precipitate from a mixture of watery solutions of eosin and of methylene blue was dissolved in methyl alcohol. The dried blood smears were covered with this stain and left for three to six minutes, according to the temperature and humidity of the air. Water was then added, a drop at a time, until the stain appeared quite thin. It was then left two to six minutes, then washed very thoroughly in water and mounted with water upon a slide and examined.

By this method the nuclei are all pale blue or purple; the lymphocytes have blue protoplasm and are hyaline, the neutrophils are light pink or lavender, with small granules; the eosinophiles are brilliant eosin color with very large granules; the basophiles are deep indigo, with very large granules.

For ordinary work a differential count based upon the naming of five hundred white cells is fairly exact. In most of the cases included in this report one thousand or two thousand white cells were counted.

Having determined in this manner the percentages of the various classes of white cells, it is necessary only to multiply the actual numbers of leucocytes per cubic millimeter by these figures in order to determine the actual number of each class of leucocytes present in each cubic millimeter of blood.

The cells found in normal adult human blood include the following classes:

- A. Erythrocytes
- B. Leucocytes.
  - 1. Hyaline leucocytes
    - a. Small lymphocytes
    - b. Large lymphocytes



## 2. Granular leucocytes

- a. Mononuclear neutrophiles
- b. Polymorphonuclear neutrophiles
- c. Eosinophiles
- d. Basophiles

C. Platelets are often included as cells, but their nature has not yet been determined.

The erythrocytes number four and one-half to five million to each cubic millimeter of blood. These figures are lower than the counts made in this locality indicate. Five to five and one-half million is more nearly an average count of the blood of normal men and women made in this laboratory. (The Pacific College of Osteopathy, Los Angeles, California.) It may be that the dry atmosphere of this climate is responsible for a certain amount of concentration of the blood.

Each erythrocyte is a thin, saucer-shaped body with no nucleus, and composed almost entirely of hemoglobin lying in the interstices of a protoplasmic stroma. The relative amount of hemoglobin carried by each erythrocyte is represented by a fraction called the color index. The color index is the fraction obtained by dividing the hemoglobin percentage by the erythrocyte percentage.

The relative amount of hemoglobin carried by any given mass of erythrocyte protoplasm is called the volume index. This is the fraction obtained by dividing the hemoglobin percentage by the volume percentage of the erythrocytes. This is secured by the use of a hemocrit.

Erythrocytes are constantly being formed by the hematopoietic cells in the red bone marrow, especially in the flat bones, such as the ribs. The life of an erythrocyte is known to be short, perhaps a matter of a few days, perhaps a few weeks. The amount of urinary and bile pigments formed from disintegrated hemoglobin each day gives some idea of the enormous destruction of erythrocytes occurring constantly in the body.

It seems that some erythrocytes are, or may be, formed by budding. These may never be nucleated. It appears certain

that they are also formed by means of the ordinary processes of karyokinesis, and that the nuclei are extruded before they go into the general circulation, under normal conditions. The number formed during any given time is only to be very vaguely determined; certainly many thousands of new erythrocytes are formed each minute of the day and the night.

Leucocytes are the colorless cells of the blood. They are always nucleated, include several different forms, and appear to have functions as variable as their structure. There are from five to ten thousand leucocytes in normal adult human blood in this climate.

The hyaline leucocytes are characterized by the absence of granules in their protoplasm. The protoplasm is scanty in amount, stains with basic stains (methylene blue, with Wright's stain), and surrounds the nucleus thinly. The nuclei of the hyaline cells are round or only slightly indented in a kidney shape. The nuclei may be eccentrically placed. Under slightly abnormal conditions and in the lower mammals the hyaline cells may contain a few basic granules. The small lymphocytes and the large lymphocytes differ chiefly in size; the large lymphocytes carry a relatively greater amount of protoplasm.

The lymphocytes originate in the lymph nodes, the red bone marrow, the spleen, the lymphoid tissue generally. The large lymphocytes make up four to ten per cent of the white blood cells, the small lymphocytes from fifteen to twenty-five per cent.

The granular leucocytes are characterized by the presence of granules of various sizes and staining properties lying in the protoplasm, apparently making up the mass of the protoplasm in some cases.

Mononuclear neutrophils carry the smallest granules. These take neutral stains; with Wright's stain they are either light pink or lavender. The nuclei are round or slightly lobed or notched, and are almost centrally placed. The cells called transitional are frequently included with this group. Two to four per cent of the white cells may be mononuclear neutrophils.

Polymorphonuclear neutrophils resemble the mononuclear

forms slightly. In these the granules are slightly larger, and they take a deeper pink color with Wright's stain. The nuclei are of many sizes and shapes. In many cases it is easy to see that the different lobes of the nucleus are united by slender threads of nuclear substance, but often the nucleus appears to be really multiple. In normal blood the polymorphonuclear neutrophiles have nuclei which look more like a ribbon folded upon itself in a rather complex manner than like a string of sausages. It is supposed that the polymorphonuclear forms are developed from the mononuclear forms, and that the greater the number of nuclei, or of distinct lobes in the single complex nucleus, the older is the leucocyte. These cells originate in the red bone marrow, chiefly, though some appear to be derived from the spleen and from the hemolymph glands. They make up two-thirds to three-fourths of the white cells of normal adult human blood.

Eosinophiles are characterized by the intensely vivid eosin color which they take with Wright's stain. The granules are very large, and take the acid stains with avidity. The nuclei are one or more and are rounded in outlines. They make up about two to five per cent of the white blood cells in human blood and originate chiefly in the red bone marrow.

Basophiles also have one or more rounded nuclei, and have their protoplasm almost filled with very large granules. These granules stain a deep and vivid indigo blue with Wright's stain. They are often lacking in normal human blood, but may take up one per cent of the white cells. They originate in the red bone marrow.

Under abnormal conditions other forms of white cells may be found in human blood.

Myelocytes are characterized by their large size, and by their large, rounded, and very eccentric nuclei. The nucleus occupies about one-third of the periphery of the cell. These are found in normal bone marrow, but only under pathological conditions do they appear in recognizable numbers in the general circulation. Rarely, one or two might be found in an ordinary smear of normal blood.





Amphophiles carry granules which have affinities for either acid or basic stains. With a pure eosin stain they appear eosinophilic, with methylene blue they appear basophilic. With Wright's stain they show both red and blue granules. These cells are normal to the blood of the lower mammals and to human blood during early foetal life. Abnormally they may be found in adult human blood.

Turck's irritation forms are usually neutrophilic. They are roughly triangular, and the large round nucleus occupies one corner of the cell. It is naked for about half its extent. These cells are normal to lower vertebrates; we have not found them normally present in the blood of any mammal examined. Under very severe nutritional disturbances they may be found in human blood.

Transitional forms occupy the gradation stages between the large lymphocytes and the mononuclear neutrophiles. They have hyaline, basic protoplasm, containing a variable number of very small neutrophilic granules. They are rarely found in normal human blood, and are included with the mononuclear neutrophiles in counting.

**Bony Lesion and Blood Formation.**—A report regarding the relationship between lesions of the ribs and vertebræ upon the formation of the blood cells was given at the meeting of the American Osteopathic Association at Minneapolis in 1909.

**Nerves of the Red Bone Marrow.**—The demonstration of the terminations of the nerves entering the red bone marrow is somewhat difficult, because of the bony spicules present. A modified methylene blue method gave best results.

The marrow was taken from the bone as soon after anesthesia was complete as possible. Pieces not more than ten millimeters were placed in a solution of 1-2% methylene blue in normal salt solution, preferably at blood temperature. After about ten minutes they became deep blue. Then they were washed lightly and quickly in water, then in a watery solution of picric acid, again in water, then the pieces were lightly teased apart in glycerine. By this technique very pretty nerve endings can be seen.

Many nerve fibers break up into fibrillæ among the marrow cells. We were not able to find any specific endings, other than these, nor were we able to find that they had any direct relation to the marrow cells. Other nerves terminate upon the walls of the blood vessels. Certain experiments indicate that these are dilator nerves.

After the preliminary anesthetic, usually ether, the thorax was opened and the ends of the ribs cut. The nerves were dissected back from the nutrient foramina for an inch or more, then cut. The vessels were kept separate from the nerves. The rate of blood flow from the cut ends of the ribs was noted, then the peripheral end of the cut nerve was stimulated—usually by a weak alternating current of electricity, but sometimes by pinching or pricking the nerve trunk. The blood flowing from the cut end of the rib increased and the blood became brighter in color. Similar tests were made upon the red bone marrow of the humerus of the cat and upon the skulls of both cats and dogs. The results were the same in all cases.

Tests were made upon human subjects in order to determine the relationship between the rib movements and the formation of the blood cells. For this purpose twenty-seven persons, suffering from no recognizable disease, but who were below par in physical vigor, were chosen. In all of these cases the hemoglobin was low; the erythrocyte count normal or higher than the average; the color index was low; the leucocyte counts showed slight variations from the normal, none constant except the relative excess of lymphocytes.

In every person thus examined the thorax was more rigid than normal and the respiratory movements were remarkably slight. In a few the respiratory excursions in quiet respiration were so slight that they could not be measured by the ordinary steel tape. The average expansion in quiet respiration was two millimeters; in forced respiration, fifteen millimeters.

Ten of the subjects were dropped from the tests for various reasons; seventeen were able to carry on the tests for seven weeks.

These persons were directed to continue in their usual habits of eating and living, except for the increasing mobility of the thorax. Three times each week treatments were given, for the correction of specific rib lesions when these were present, and for raising the ribs and increasing the mobility of the thorax in all. Breathing exercises adapted to each person's condition were outlined, and these also were planned for raising the ribs, increasing the mobility of the thorax, and thus facilitating the efficiency of the circulation and nervous control of the ribs. The obedience with which these directions were followed was evident in the fact that the expansion in quiet breathing increased from one to five millimeters, while the expansion in forced respiration increased slightly.

The blood was examined for each person at rather irregular intervals, depending upon circumstances. At the end of seven weeks the blood was examined for each person, and the records compared. The following changes were found to have occurred, evidently as the result of the treatment as outlined:

The hemoglobin was increased in every person, the average increase being 19% by Dare's hemoglobinometer;

The erythrocytes approached the normal in each case in which the normal count was not present at the beginning of the tests. There was an average loss of 5% in actual numbers; this was associated with increased regularity and size of the cells themselves;

The color index was raised in all but one case, the average rise being .185;

Microcytes were present in five cases at the beginning of the experiments. None were found in the last examination;

Poikilocytes were present in six cases at the beginning of the tests. A few were still present in three cases at the last examination;

In two cases the leucocytes were slightly diminished; in six they were slightly increased, in the other cases no changes were apparent. The white cells either remained normal from the beginning or approached normal during the tests. This was



true both of the percentages of the various classes and also of the actual numbers of each class present in each cubic millimeter of blood.

From these tests and from a study of clinic patients during their improvement, it appears that the character of the blood may be seriously modified by a lack of mobility of the ribs. The location of those bony lesions which affect the digestion and absorption of food, or the elimination of the bodily wastes, is evident. In addition, the place of the thoracic rigidity in interfering with the normal circulation and innervation of the red bone marrow must not be forgotten.

The habit of pronounced abdominal breathing, the wearing of clothing which impedes the movements of the ribs, and a sedentary life are important factors in causing these slight forms of anemia. An interesting point in development may be noted: One effect of our civilization is an endeavor to prevent manifestations of emotional storms. Thus civilized man does not yawn, laugh, or weep extravagantly, or display much of any feeling by means of the breath variations. Children and certain savage races are wiser; the respiratory movements thus made extravagant, increase also the circulation through the red bone marrow and the formation of blood cells. Perhaps no one would advocate a return to savagery for the sake of securing red blood cells, but certainly a return to the more mobile thorax and the greater chest expansion in quiet respiration is worth while for the sake of redder and better blood.

**The Blood of Neurasthenics.**—A report was made upon this subject at the meeting of the California State Osteopathic Association held in San Diego in May, 1909. The blood of thirty-three neurasthenic patients, without recognizable organic disease, was examined one or several times. The results are as follows:—

Specific Gravity .....	Decreased
Coagulation Time .....	Increased
Hemoglobin .....	.61.8% of the normal
Erythrocytes.....	104.4% of the normal
Color Index.....	.61





Leucocytes .....	14593	per cubic millimeter
Large Lymphocytes.....	711	per cubic millimeter
Small Lymphocytes .....	2743	per cubic millimeter
Mononuclear Neutrophiles .....	159	per cubic millimeter
Polymorphonuclear Neutrophiles..	10287	per cubic millimeter
Eosinophiles.....	496	per cubic millimeter
Basophiles .....	197	per cubic millimeter

Amphophiles, present in 9 cases.  
 Neutrophilic Myelocytes, present in 11 cases.  
 Microcytes, present in 12 cases.  
 Poikilocytes, present in 21 cases.  
 Microcytes, present in 1 case.  
 Normoblasts, present in 3 cases.

Examinations of the blood of fifty other patients with neurasthenic symptoms verifies the results given in this report.

The blood of neurasthenic patients shows the following characteristics: Low hemoglobin, high or normal erythrocyte count, low color index, slightly increased leucocyte count, eosinophilia, and a tendency to the appearance of the immature or atavistic forms. In a few cases the blood of patients supposed to be neurasthenic has varied recognizably from this picture. In all such cases some organic lesion has become manifest upon further investigation.

A report upon "Some Atavistic Characters of Abnormal Blood" was made in 1912. A summary was given before the meeting of the American Osteopathic Association in Detroit, and the paper was published in the Journal of the Association for September, 1912. This report was based upon a study of five hundred examinations of human blood and of the blood of thirty animals. Since that time the blood of other animals and of human beings under various abnormal conditions has been examined. These later tests add to the number of facts and to the details of the relationships, but do not, so fail to verify the conclusions given in that report.

**Hemoglobin.**—The hemoglobin percentage (Dare) varies rather irregularly among different animals. In general, the amount of hemoglobin increases from the lower vertebrates to the higher, from the young of all animals to the old, and is lower under abnormal conditions. There are certain exceptions to

these statements, as the percentage of hemoglobin is very high in diabetes, both insipidus and mellitus, due to the concentration of the blood. Dietetic variations modify the hemoglobin also.

**Color Index.**—The color index also varies irregularly. In non-mammals the color index is high, because the erythrocytes are very large. This is the case also in pernicious anemia. In small animals (for example, mice), the color index is usually low because the erythrocytes are small. The color index rises from foetal life to youth and from youth to old age. It is usually lowest in abnormal conditions, both among animals and human beings.

**Volume Index.**—The volume index refers to the relative amount of hemoglobin carried by a given amount of erythrocyte cytoplasm. The volume index is thus indicative more exactly of the evolution of the hemoglobin. It increases invariably from the lower to the higher vertebrates, from foetal to young blood, and from young blood to that of old age. It is higher under normal than under abnormal conditions, including diabetes and pernicious anemia.

**Erythrocytes.**—Below mammals the erythrocytes are oval, large, nucleated, and rather irregular in shape and size. They are usually fairly constant in staining, so far as the stroma is concerned, but vary in the density, due to hemoglobin. The stroma is very distinct and often includes granules of varying affinities.

Among mammals the lower forms generally show the more distinct stroma, the lower volume index, the greater irregularity of size, shape, and staining, and the greater tendency to disintegration during the manipulations necessary to counting and staining.

The ontogenetic development presents a similar series of events. From foetal blood to that of youth, from youth to adult life, and, under normal conditions, to old age, the erythrocytes contain a relatively greater amount of hemoglobin, are more regular in size, shape and staining, and retain their outlines more

constantly during the technique of the tests made in the preparation of this report.

The macroblast of pernicious anemia has long been considered a "harking back" to the invertebrate type of erythrocyte. The low color index in chlorosis and in secondary anemias, the low volume index in most diseases, the presence of poikilocytes, and the speedy disintegration of the erythrocytes in the making of smears and in the counting pipettes and chamber are characteristic alike of abnormal blood of human beings and animals, of the younger children and animals, and of the lower forms of mammalian blood.

**Leucocytes.**—Generally speaking, the leucocyte varies under both physiological and pathological conditions more rapidly in the lower mammals than in the higher; in the young than in the old, and in the feeble than in those of robust physique. It is thus evident that fluctuations in the leucocyte count are of less significance in the blood examinations of children and of feeble adults than in the examinations of the blood of robust adults.

**Lymphocytes.**—In all of the blood examined, human or animal, young or old, normal or diseased in any way, the hyaline cells are basophilic. The giant mononuclear hyaline cells are not normally found in the blood of any mammal examined. They are normal to birds, reptiles, and amphibia, and are found under certain very severe nutritional disturbances (pernicious anemia, spleno-medullary leukemia, just before death in a meningitis following a long septicæmia, etc.).

The large and small lymphocytes decrease in percentages from the lower to the higher mammals, from the foetal to the young, and from youth to old age, and under most conditions associated with diminished nutrition.

**Neutrophiles.**—Neutrophiles are rarely present below mammals, and are so unstable that they appear to be more rare than they really are. They are almost or quite invariably mononuclear in non-mammalian blood.

Among mammals the percentages of neutrophiles increase from the lower to the higher forms of life, from foetal to youthful

blood, and from youth to old age. Under abnormal conditions these cells vary in both directions, being diminished relatively in mal-nutrition and increased in the presence of inflammatory conditions.

The nuclei of neutrophiles present interesting variations. The mononuclear type is, phylogenetically, ontogenetically, and perhaps, individually, the youngest form. The fewer the number of nuclei, the younger is the cell type. Blood containing larger numbers of neutrophiles having one or two nuclei is thus to be considered more immature than blood containing great numbers of neutrophiles with four to six or more nuclei.

**Eosinophiles.**—Eosinophiles vary irregularly in phylogenetic and ontogenetic development. Among lower mammals the granules are often extremely large and are sometimes rod-shaped, as in the horse. They have generally larger and rounder nuclei in the lower forms of mammals and in immature blood, but this is not constantly true. Under abnormal conditions they appear to be increased in the presence of animal invasions practically invariably, and after certain bacterial infections. In certain functional variations, both physiological and pathological they may be increased. Their absolute numbers are decreased in tuberculosis and under certain other less well recognized conditions.

**Basophiles.**—Basophiles are found in great numbers in most non-mammalian blood. They are more often mononuclear among the lower forms, both of mammalian and non-mammalian blood. They are often absent in normal adult human blood, and may or may not be increased under pathological conditions. Basophilic granules are often present in the hyaline cells of the lower mammals and non-mammals, but are rarely found in normal adult human blood. They are sometimes found in human foetal or placental blood, in children's blood, and in the blood of adults suffering from severe mal-nutrition.

**Amphophiles.**—Amphophiles are found in the blood of non-mammals and of the lower mammals. The most beautiful amphophiles found in this laboratory (Laboratory of Physiology,

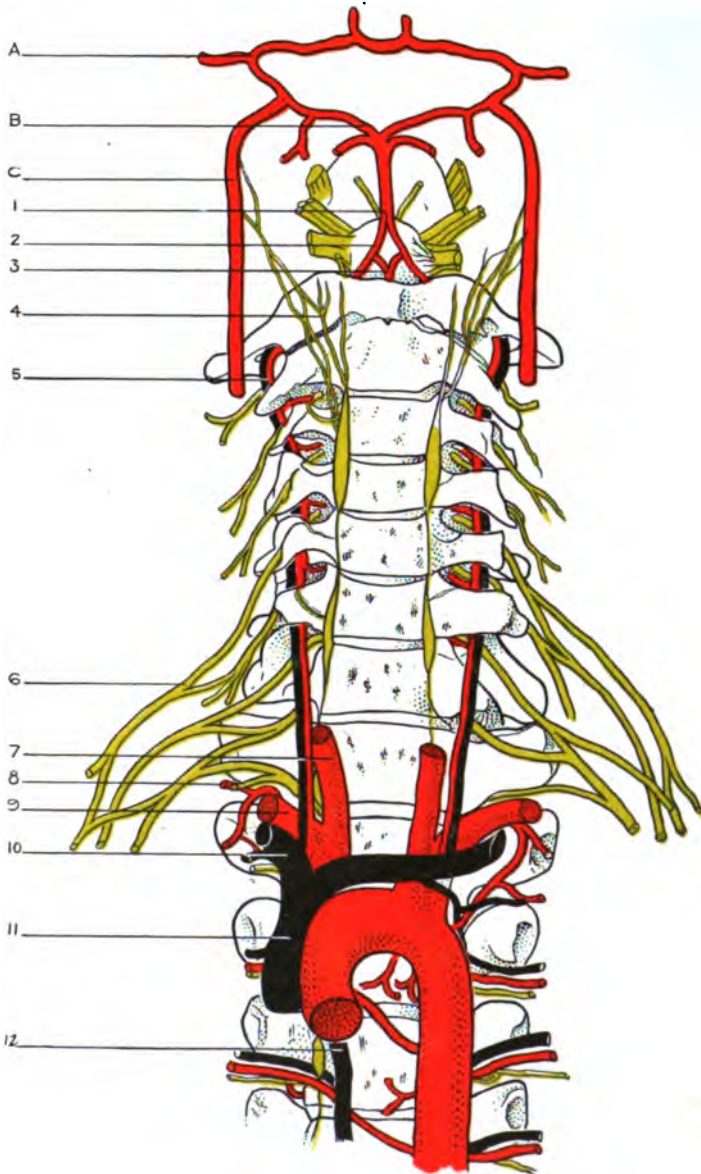

PLATE XXXVI.—Showing the arterial connections between the brain and cord and the cervical autonomies extending to the arteries of the head and neck. Note the close structural relations of bony framework with the blood and nerve supply. A, circle of Willis; B, posterior cerebral; C, internal carotid; 1, basilar artery; 2, vertebral arteries; 3, anterior spinal arteries; 4, sympathetic chain; 5, vertebral artery and vein in transverse process; 6, brachial plexus; 7, carotid artery; 8, first intercostal artery; 9, subclavian artery; 10, subclavian vein; 11, superior vena cava; 12, vena azygos major.





The Pacific College of Osteopathy) have been those from the blood of a Belgian hare which was about half grown. They were not found in appreciable numbers in normal dogs or cats nor in the blood of normal people. In severe secondary anemia, after profound hemorrhages, in the leukemias, and under a number of varying cachexias, amphophiles were found in adult human blood.

Since these reports were first published many other blood examinations have been made of normal and abnormal persons and of normal and abnormal animals, in both cases of many ages. These later tests verify the findings first reported in every case.

## CHAPTER XLVIII

### REFLEX ACTIONS.

The manner in which the body as a whole reacts to the changes in the environment of any of its parts or the variations in the conditions of any of its parts, depends largely upon the existence of a complex series of nervous activities which are called reflex actions.

A reflex action is any variation of physiological activity which results from a motor-nerve impulse initiated by a sensory impulse, without the intervention of consciousness.

It is at once evident that a very large proportion of the phenomena of the daily life of human beings and of many animals is based upon reflex actions; it is also evident that the greater the possible number of reflex actions and the greater the flexibility of the adjustments secured by these reflexes, the greater is the efficiency of the organism.

The efficiency of reflex actions depends chiefly upon the structural and physiological relationships of neurones arranged in groups within the central nervous system. Such groups of neurones arranged in such a manner as to control the activity of any organ or group of organs, or for the performance of any specific function, are called nerve centers.

Nerve centers may be considered as individual groups of neurones, for purposes of discussion, but it must be remembered that the same phenomena might be produced by the varying activities of groups of cells acting under varying circumstances that would be produced by entirely different cell groups. It is at present impossible to determine the actual extent of any of the more complex nerve centers; that is to say, the physiology of the nerve centers has been studied more exactly than has their morphology or their histology.

The typical nerve center is, in a sense, the keystone of a reflex arc. It receives the axons of sensory neurons, usually both of the first and second orders, and sometimes of higher orders; it includes association cells, and it sends the impulses co-ordinated by these varied activities to the active tissues of the body by way of motor neurons of the first, second, or higher orders. In addition to these neurons, essential to nervous activity of more than the simplest type, each neuron receives axons from the nerve centers of related function and sends axons to them. Thus the structural relationships of the nerve centers are complex and varied, and the functional relationships are such as enable them to perform the most complex, varied, and efficient actions. In the case of the nerve centers of the spinal cord, it is known that the descending spinal tracts carry nerve impulses from many higher centers which may increase or decrease the activities of the centers themselves or of the neurons composing them.

The activity of any nerve center may be modified by any of the following factors:—

1. The structural relationships of its neurons. Not only are the functions of normal nerve centers dependent upon the existence of cells and axons for the co-ordination of the nerve impulses, and nerve fibers for the transmission of these, but under abnormal conditions the structural relationships may become disturbed to such a degree as to prevent normal activity. The failure of a normal structural development of the nerve centers underlies the physiological and mental defects of idiot, imbecile, and feeble-minded children. There is some reason to believe that the functional nervous weakness in many hysterical and neurasthenic patients depends upon a lack of the proper structural development of the neurons of the central nervous system.

2. The physiological condition of the neurons composing the center. Neurons which are fatigued do not react in the same manner as do rested neurons. Neurons which are well fed with clean blood, flowing freely under normal pressure, derived from well-digested, nutritious food, behave in such a manner as to adapt the body to its environment most efficiently; but a lack

of nutrition, of oxygen, or of the internal secretions, or the presence of any of a long list of poisons of intrinsic or extrinsic origin, or too low or too high a pressure of the blood, or any other abnormality in the nutrition of the neurons, prevents the most efficient activity. Neurons which are frequently stimulated react more speedily and usually more efficiently than do those which are rarely stimulated. Under certain circumstances the increased or decreased activity of one center may render centers of related function more easily stimulated or more resistant to stimulation.

3. The character of the nervous stimuli reaching them. Thus the spinal centers may be stimulated by sensory impulses from the same or adjacent spinal segments; by impulses from centers of related function; by impulses descending from the centers of the medulla, pons, cerebellum, mid-brain, basal ganglia, and cerebral cortex. Volitional impulses may affect the activities of certain spinal centers also. The activities of the higher centers are modified in practically the same manner as the spinal centers, with such modifications as depend upon their structural relationships. The nerve impulses may either increase or inhibit the activity of any center.

**Bony Lesions.**—The anatomy, histology, and physiology of the spinal cord and the sensory ganglia indicate that the most important factor in the relationship between the slight mal-positions of vertebræ, ribs, and other bones is found in the phenomena of reflex action. These slight mal-positions are called "bony lesions."

Bony lesions may modify the activities of the spinal centers by modifying the character of the sensory impulses. This effect is probably secured by impulses passing over several varying pathways. Perhaps one of the most important effects is produced by the irritation of the sensory nerve endings upon the articular surfaces of the bones whose relationships are disturbed. A number of experiments have been performed by several observers in different laboratories in the effort to explain the effects produced by bony lesions. The work done in the laboratory of physiology of The Pacific College is here given in summary.

The experiments were performed upon animals and human beings. For the most part, the tests were limited to the immediate effects of bony lesions. Of animals, cats, dogs, guinea pigs, white rats, and rabbits were employed. Ether was the usual anesthetic and anesthesia was complete before any mutilating or painful tests were made.

After the anesthesia was complete, the viscera to be studied were exposed to view. Acids, hot glass tubing, prickings, chemical substances, and light electric currents from a DuBois Raymond coil were used for stimulation. The electric current was most useful, and was usually barely perceptible to the touch. The length of the tests was limited to the time during which life could exist under anesthesia and during the necessary mutilations. No animal was ever permitted to suffer, or to regain consciousness after the anesthetic was begun.

**Effects of Spinal Stimulation.**—In one series of tests the effects produced upon viscera, blood vessels, glands, and the skeletal muscles by stimulation of the tissues near the spinal column were studied. After anesthesia the viscera were exposed to view, and the tissues to be manipulated were brought into a convenient position. The tests were repeated upon different animals, and in regard to the larger viscera of the cranial, thoracic, abdominal, and pelvic cavities. The changes were noticed by several observers, working independently; these were often students who did not know what reaction was expected, but were merely told to report whatever changes they noticed. Secretions were collected and analyzed in a few instances. The results of these tests are given in general at this time, and the results of localized tests are given in a later paragraph.

Stimulation of the skin may be followed by no recognizable effects. Sometimes slight variations in the circulation of the blood, the secretion of large glands, peristalsis, or the tone of the deeper muscles could be recognized. Both in human beings and in animals irritation of the skin over the back of the neck produced dilatation of the pupils.

Stimulation of the superficial spinal muscles produced about the same effects.

Stimulation of the deeper spinal muscles was followed by increased tone of the skeletal and visceral muscles, constriction of the arteries, and in some cases by increased secretions.

These effects were more marked when the stimulation was applied to the muscles near the vertebræ than when the muscles of the same layer but further from the spinal column were stimulated.

Stimulation of the articular surfaces of the vertebræ, ribs, and the scapula, clavicle, mandible, and skull was followed by still more marked effects. Peristalsis was increased, blood pressure noticeably raised, partly by the increased tone of the vascular walls. The secretions were increased in quantity, and the skeletal muscles innervated from the same segment were strongly contracted. In the case of the salivary glands the amylolytic power was increased by irritation of the articular surfaces of the mandible. In the case of the vertebral articular surfaces the effects produced were broadly segmental.

**Effects of Visceral Stimulation.**—In another series of experiments the effects produced by visceral irritation upon the spinal muscles were studied. In this series the stimulation was applied to the viscera and the location of the reflex muscular contractions thus produced was noted. The deeper spinal muscles and the intercostal muscles innervated from the same segment which sent sensory nerves to the viscera stimulated were invariably contracted. Muscles innervated from neighboring segments, and the larger and more superficial muscles of these segments were usually contracted. The muscles of the limbs were rarely contracted. The area of reflex muscular contraction increased when the stimulation was long continued.

The reflex muscular contractions thus produced should be considered an efficient cause of further irritation to the spinal centers. The reflex paths apparently include the same spinal centers and the same nerve trunks, for the most part, whether the sensory impulses from the viscera affect the spinal muscles,

or the irritation from the vertebral or costal articular surfaces affects the condition of the viscera or the tone of the blood vessels.

From this series of tests, including several hundreds of experiments, the following conclusions concerning the nerve centers and the effects of bony lesions have been based:

Bony lesions are slight mal-positions of the bones, usually the vertebræ or ribs, which are less pronounced than dislocations, by means of which the articular surfaces are thrown into a state of more or less strenuous tension. This stress upon the articular surfaces is a constant source of irritation to the sensory nerve endings therein, and is thus a cause of abnormal nerve impulse reaching the nerve centers of that particular segment of the cord. The ultimate effects thus produced may be variable—since too great activity of any neuron or neuron system may lessen or increase its liminal value, or may even result in a sort of functional paralysis. Some disturbance of the function of the centers of that segment of the cord, and ultimately of neighboring segments also, is probably invariable.

Disturbance of the activity of any of the centers of the cord means a disturbance of the structures innervated from those centers. The effects produced upon the body itself thus depend in part upon the location of the lesions and in part upon the nature of structures innervated from that part of the cord. When the centers controlling the circulation are affected, then the nutrition of the nerve centers is apt to be affected by this disturbed circulation. When the centers controlling the digestion or the absorption of food are affected the nerve centers also are poorly nourished. When the circulation through the flat bones, especially the ribs, is affected, then the quality of the blood becomes abnormal, and the nerve centers are thereby affected. So, whatever the effects produced upon the body metabolism, there is usually also an indirect effect upon the nerve centers as well as the more direct effects of the modified stream of sensory impulses from the strained articular surfaces.

The cells of the anterior horns of the spinal cord are arranged in two groups—a mesial cell group, composed of rather small



cells with correspondingly fine axons, and a lateral cell group, composed of larger cells with coarser axons.

The cells of the mesial group send their axons into the smaller muscles of the deeper layers of the back and neck. It is their especial function to maintain the erect position and to keep the vertebral relationships normal. These cells are very intimately associated with the sensory neurons, visceral and somatic, and with the cells of the neighboring segments of the cord. They receive descending impulses from the cerebellum, pons, medulla, mid-brain, and ganglionic centers in a noticeable degree, but only to a slight extent are controlled by impulses from the precentral areas of the cortex.

The cells of the lateral group of the anterior horn are found best developed in the cervical and lumbar enlargements. They send their axons to the large muscles of the back and shoulders and hips, and of the arms and legs. They are not especially intimately associated with the sensory neurons of the same segments of the cord, though there is a certain amount of connection in function. These cells receive impulses from the cerebellum and from the precentral areas of the cortex to a great degree, but only rather slightly from the medullary and pontine centers. Visceral or other sensory nerve impulses rarely produce reflex muscular contractions of the limb muscles to any great extent.

With the quantitative exceptions just noted, the cells of these groups of the anterior horns are controlled by means of impulses carried by about the same pathways.

1. Axons and collaterals from the sensory neurons of the first or higher orders form synapses with these cells. By this means the simple and the more complex reflex actions are co-ordinated.

2. Axons and collaterals from neighboring segments of the cord, and from the cerebellar, medullary, pontine, tectal, and ganglionic centers reach these cells, either directly or by way of the cells of the middle of the spinal gray crescent. By this means the more complex reflexes and the reactions characteristic of the emotional and instinctive activities are probably carried.

3. Fibers of the direct and the crossed pyramidal tracts carry impulses from the precentral areas of the cortex to the spinal cells, either directly or by way of the cells of the center of the crescent. By this means the volitional impulses are carried.

These structural relationships of the anterior horn cells underlie the varied functions which are performed by them. So long as the impulses reaching these cells are normal and the cells themselves are normal in structure and environment, then the activities are for the best good of the body. But when any of the pathways for the normal nerve impulses are impeded, or when the blood is deficient in quality, or when the flow of the blood is in any way disturbed, then the activity of these cells is not that associated with the best reaction of which the body is capable. These disturbances in the nerve relationship or the nutrition of the nerve cells are caused by a number of conditions—poisons of various kinds in the body, injuries, pressure from tumors, hemorrhages, etc.—and not by any means the least, the presence of bony lesions.

The centers which control the visceral muscles, the secretion of the glands, the muscles of the walls of the blood vessels, and the muscles which raise the hairs, all are placed in the lateral horns of the cord whose cells send their fine axons into the sympathetic ganglia. From these ganglia other axons pass, which have no medullary sheaths, to terminate in the non-striated muscles and glands.

The cells of the lateral horns of the cord are controlled by nerve impulses from the following sources:—

1. Nerve impulses from the sensory neurons of the first or higher orders, of the same or neighboring segments of the cord, bring about the visceral or somato-visceral reflex actions. By this means, normally, the body is enabled to act as a unit in the presence of varying bodily conditions. Abnormally, by this means, the effects of bony lesions and of irritations from diseased viscera are enabled to perpetuate the abnormal condition and to vary the visceral and vascular activities in a manner which is, often, not for the best good of the body.

Descending impulses from the higher centers, certainly from the centers of the medulla, pons, and mid-brain, and probably of the cerebellum and ganglionic centers, bring the activities of these spinal centers into harmony with the needs of the entire body, in its complex reflex actions and in its instinctive and emotional states.

The activity of these visceromotor, vasomotor, and secretory centers may be affected abnormally by the bony lesions already mentioned in connection with the cells of the anterior horns, and by the quality and the pressure of the blood flowing through them. Since the nutrition and circulation of the entire body depend to so great a degree upon these visceral centers, it is evident that any mal-function of these centers must in turn act upon them in a detrimental manner.

## CHAPTER XLIX

### THE SPINAL CENTERS.

The centers of the spinal cord may be divided for convenience into groups, though it must be remembered that this division is largely empirical. The most convenient grouping includes an upper cervical, lower cervical, upper thoracic, lower thoracic, and the lumbo-sacral groups of centers.

**The Upper Cervical Group.**—The centers of the upper cervical cord lie in the gray matter of the first to the fourth cervical segments, inclusive. This occupies the upper cone of the cervical enlargement.

The anterior horn is large and broad. Its mesial cell column innervates the trunk muscles, as does the entire column of these cells throughout the spinal cord. In the upper cervical group these muscles include, by the posterior primary divisions of its nerves, the superior and inferior oblique, the rectus capitis posticus major and minor, the complexus, trachelo-mastoid, the splenius and semi-spinalis, the multifidus spinæ, the transversalis cervicalis, the cervicalis ascendens. By the anterior primary divisions these centers innervate the splenius, platysma, longus colli, scaleni, rectus capitis anticus major and minor, and the rectus capitis lateralis, and a part of the sterno-mastoid. The hyoid muscles receive, also, fibers from a small cell group in the antero-lateral part of this column.

These cell groups are phylogenetically of great age; they are intimately associated with the cells of the posterior and lateral regions of the cord, and are easily affected by sensory impulses from the viscera and skeletal structures innervated, either directly or indirectly, by way of these segments. They are found abnormally contracted under many very varied abnormalities

of the cranial, cervical, and thoracic viscera, and also in certain abdominal and pelvic diseases.

The antero-lateral cell group of the anterior horn sends axons to the larger and more superficial muscles. These cells are less intimately related to the cells of the other areas of the spinal gray matter, and thus are less frequently stimulated by sensory impulses from diseased viscera or abnormal conditions in the body. The levator scapulæ, teres major and minor, supraspinatus, and the rhomboids are innervated by these nerve cells. They are of a rather late phylogenetic development, and are less often subject to reflex disturbances in tone than are the deeper muscles.

The lateral horn is not well developed in the upper cervical cord. Cells apparently homologous with the lateral-horn cells innervate chiefly the sterno-mastoid and the trapezius, by way of the spinal portion of the eleventh cranial nerves. These muscles are especially subject to reflex contraction. The trapezius and the sterno-mastoid are homologous with the muscles of the ancient gill-cleft musculature, and are in this way related to visceral muscles. This primitive relationship doubtless affords the structural basis for the remarkable susceptibility of these neurons to stimulation from sensory impulses from viscera, skin, articular surfaces, and other tissues innervated from the upper cervical sensory nerves.

The posterior horn of the upper cervical cord is capped by the substantia gelatinosa, in which the descending fibers from the fifth cranial nerves terminate. The sensory fibers of the eighth, ninth, and tenth cranial nerves also send collaterals and terminals into the gray matter of these segments. The sensory fibers of the upper cervical segments innervate the skin over the back of the head, the neck, and over the scapula and shoulders.

Impulses from the skin of these regions, from the corresponding articular surfaces of the vertebræ, or from the areas supplied by the fifth, ninth, tenth, and part of the eighth cranial nerves, may affect the activities of the upper cervical centers. It must be remembered that sensory impulses from the tissues innervated

by the sensory fibers of the fifth, eighth, ninth, and tenth cranial nerves, as well as from the first to the fourth cervical nerves, may cause abnormal contractions of the muscles already named as being innervated from these centers; and it must also be remembered that the abnormal muscular contractions, especially of the muscles of the anterior neck region, may be responsible for such pressure upon the nerves, ganglia, blood vessels, lymphatics, etc., of the neck that serious disturbances may result.

**The Lower Cervical Group.**—The lower cervical group includes the nerve centers located in the fifth cervical to the first thoracic segments of the cord, inclusive. These segments include the lower cone of the cervical enlargement. The anterior horns are large and broad, and they include a lateral and an anterior cell mass, as is the case in the upper cervical group.

The mesial cell group represents the older structure, phylogenetically. Their central relationships are very complex and they are very liable to the effects of disturbed sensory impulses. The axons from the mesial cell innervate the muscles of the trunk, including the semispinalis, multifidus spinæ, trachelo-mastoid, scaleni, longus colli, cervicalis ascendens, transversalis cervicis, complexus, and splenius.

The lateral cell mass includes several groups whose relations have not yet been fully determined. The cells send axons to the muscles of the shoulder girdle and the arms and hands. These include the teres major and minor, supraspinatus and infraspinatus, rhomboid, anconeus, subscapularis, serratus magnus, pectoralis major and minor, coraco-brachialis, deltoid, biceps, triceps, brachialis anticus, supinators longus and brevis, latissimus dorsi, the pronators, extensors and flexors of the wrists and fingers, the lumbricales and interossei, the thenar and palmar muscles.

The cells of the lateral cell masses are less intimately associated with other cell groups of the cord, and are less easily subject to the effects of sensory impulses than are the cells of the mesial cell mass.

The visceromotor column, or the lateral horn of the cord, is scarcely represented in this group of nerve centers. A few fibers

enter the phrenic nerve from the upper part of the group, and a few assist in forming the eleventh cranial nerve. The first thoracic and probably the seventh cervical segments appear to contain a part of the cilio-spinal center, or to be in close relationship with the cells of this center.

The posterior horn is still capped by the *substantia gelatinosa*, and probably some of the descending fibers of the fifth cranial nerve reach these segments. It is certainly true that impulses from the area of distribution of the fifth cranial nerve initiate reflex contractions of the muscles innervated from the mesial cell mass of these segments. The sensory fibers entering these segments innervate the skin over a small part of the anterior and the posterior wall of the thorax, the arms, hands, and fingers; the muscles innervated by the same segments; the articular surfaces of all the bones moved by these muscles; the meninges of the corresponding spinal segments. No viscerosensory nerves have been described, except as has already been mentioned, indirectly, by way of the descending fibers of the fifth and possibly other cranial nerves.

Lesions affecting the articular surfaces of the fourth cervical to the fifth thoracic vertebræ, the first ribs, clavicle, or scapula may cause abnormal contractions of the muscles named, and may thus interfere with the shape and size of the thoracic inlet. Thus the circulation through the viscera of the head and neck may be interfered with.

**The Upper Thoracic Group.**—The upper thoracic group of centers lies within the gray matter of the second to the sixth thoracic segments of the cord. Probably these centers intrude upward into the lower cervical group, and downward into the lower thoracic group, to a certain extent.

The anterior horns of these segments are long and narrow. It includes cells homologous with the mesial cell group of the cervical and lumbar regions. These cells are easily affected by abnormal sensory impulses from diseases of the viscera innervated from these segments. The reflex contraction of the intercostal muscles in pulmonary tuberculosis is recognized by most phy-

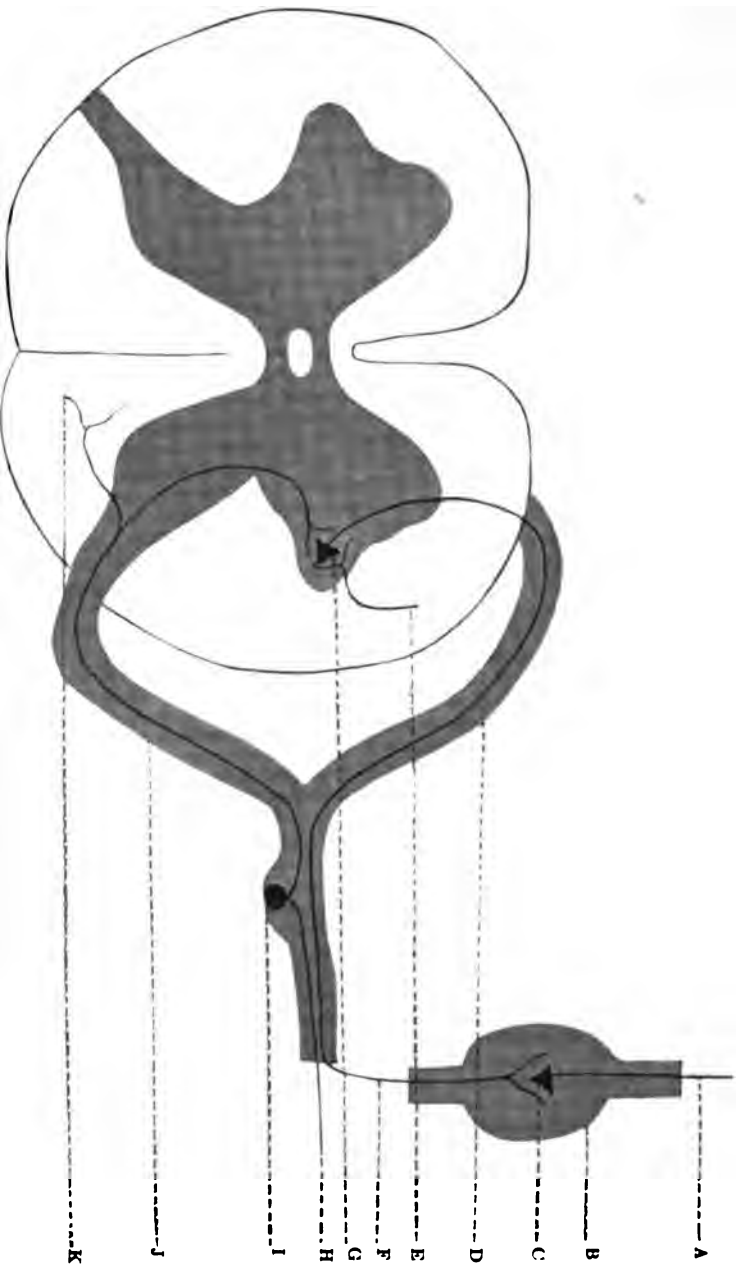

Fig. 63.—Cilio-Spinal Center. (Courtesy of Dr. Burns.) A, Gray fiber; B, sympathetic ganglion; C, sympathetic cell; D, anterior root; E, rubro-spinal; F, white ramus; G, lateral horn; H, sensory fiber; I, sensory cell; J, posterior root; K, dividing fiber.



sicians, whether they realize the full significance of the relationship or not.

The cells of the anterior horns send axons to the *semispinalis dorsi*, *spinalis dorsi*, *multifidus spinæ*, *rotatores spinæ*, *intertransversales*, *interspinales*, *longissimus dorsi*, *accessorius*, *levatorum costarum*, *serratus posticus*, the intercostal muscles of the corresponding segments, and, by a few fibers, to the external oblique.

The lateral horn is well developed. It includes cells which form a number of visceromotor centers, all of which are closely related and which are controlled, for the most part, in about the same manner. All of these receive sensory impulses from the area of sensory distribution of the nerves of the upper thoracic segments; all are controlled in part by descending impulses from the centers in the pons, medulla, mid-brain, cerebral ganglia, and perhaps, in part, from the cerebral cortex.

**The Cilio-Spinal Center.** — The cilio-spinal centers lie within the gray matter of about the sixth or seventh cervical segments to the fourth thoracic segment. It seems to be chiefly located at about the second thoracic segment. This center presents several peculiarities. The impulses from the retina are carried to the brain by the optic nerves and tracts, of which about one-fourth terminate in the anterior quadrigeminate bodies. From these bodies other fibers transmit impulses to the centers beneath the aqueduct, and from these, in turn, the tecto-spinal tracts carry impulses downward to the cilio-spinal center. Descending impulses from the centers which are concerned in the emotional states also are factors in affecting the circulation of the orbit, the dilatation of the pupils, and the secretion of tears.

The fibers from the cilio-spinal centers leave the cord as white rami, chiefly with the second and third thoracic anterior roots of the cord. They enter the sympathetic chain and pass uninterrupted to the superior cervical sympathetic ganglion. Here they break up into many fine branches which enter into the formation of the pericellular baskets of this ganglion. The axons of the sympathetic cells thus affected pass to the orbital structures.

The vasomotors follow the carotid artery in part. Other non-medullated fibers pass near the Gasserian ganglion and are carried to the orbit with the long ciliary nerves. None of these fibers enter into physiological relations with the ciliary ganglion, which is controlled by the third cranial nerve. The cilio-spinal center, by these path-ways, controls the circulation through the orbital tissues, and the tear glands, the dilator muscles of the pupil, the non-striated fibers of the levator palpebrarum, and the non-striated muscle fibers of the capsule of Tenon.

**Centers Controlling the Cranial Viscera and Blood Vessels.**—The centers which control the circulation through the cranial structures and the secretion of the glands of the head and neck are located chiefly in the gray matter of the upper thoracic segments of the cord. The vasomotor centers for the head region are placed, for the most part, in the lateral horns of the first to the fourth thoracic segments, though neighboring segments may include cells associated with this function. The axons of cells of this region pass as white rami communicantes into the sympathetic chain and pass in this chain to the superior cervical sympathetic ganglion, where some of the fibers terminate, and thence to the smaller ganglia in the cranial cavity, where other fibers terminate. The non-medullated fibers which are the axons of sympathetic cells pass to the walls of the blood vessels, the viscera, the pilomotor muscles, and other tissues of the head and neck region. The presence of vasomotor nerves in the brain has been a matter of dispute; recent experiments appear to indicate their presence. The presence of vasomotor nerves in the cerebral and spinal meninges is unquestioned.

The nerves controlling the activities of the glands and the non-striated muscles of the head follow about the same pathway, and are liable to practically the same series of effects under pathological conditions.

**Secretory and Vasomotor Centers for the Throat and Neck.**—The centers controlling the circulation through the tissues of the neck and the throat and the secretion of the glands of this region are placed in the gray matter of the second to the fifth

thoracic spinal segments, with probably some intrusion upon neighboring segments. The white rami fibers originating in these segments, carrying impulses destined for the viscera and blood vessels of throat and neck, pass by way of the sympathetic chain to the middle and superior cervical ganglia, where they terminate in the pericellular baskets. The gray fibers, which are the axons of the sympathetic cells, join the cranial and the cervical nerve trunks or become associated with the arteries, and are thus carried to the areas of their distribution.

**Brachial Vaso-motor and Viscero-Motor Control.**—

The blood vessels, the sweat and sebaceous glands, and the pilo-motor muscles of the shoulder girdle, the arms and hands, are controlled by centers located in the third to the fifth thoracic segments, with probably some intrusion upon neighboring segments. Nerve impulses for this purpose are carried by the white rami of these segments by way of the sympathetic chain to the ganglion stellatum. Rarely, in the cat and the dog, the middle cervical ganglion appears to be associated with this series. From the ganglion stellatum gray fibers pass to the nerves of the cervical plexus, and thus, with them, to the tissues named. The palmar surfaces of the tips of the fingers appear to receive no vasomotor nerves, and the palms are very scantily supplied.

**Spinal Cardiac Centers.**—The centers concerned in increasing the rate and force of the heart's beat lie within the second to the fourth thoracic segments with outlying cells in the first, fifth, and sixth segments. The fibers carrying the impulses controlling these functions leave the cord with the anterior roots, pass as white rami into the sympathetic chain, and travel upward to the cervical region. They terminate by forming synapses with the cells in the superior, middle, and perhaps the inferior cervical ganglia. The gray fibers join the vagus, and are carried in this nerve to the cardiac ganglia. It is not probable that the gray fibers form synapses with the cells of the intrinsic cardiac ganglia; it is known that the vagus fibers themselves do thus terminate, at least in part.

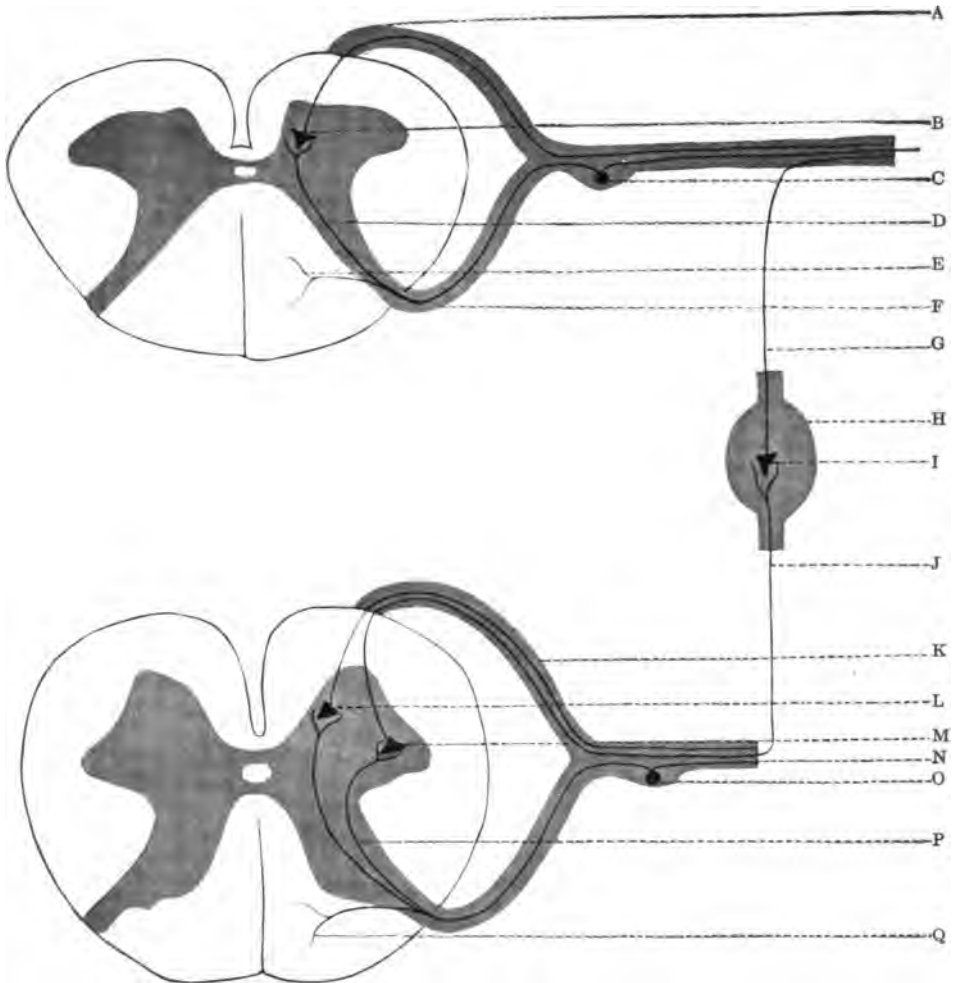

**FIG. 64.—CONTROL OF THE BRACHIAL CIRCULATION.** (Courtesy of Dr. Burns.) A, anterior root; B, anterior horn cell; C, sensory cell; D, sensory axone; E, dividing axone; F, posterior root; G, gray fiber; H, sympathetic ganglion; I, sympathetic cell; J, white fiber; K, anterior root; L, anterior horn cell (somatic efferent); M, lateral horn cell (visceral efferent); N, sensory fiber; O, sensory cell; P, sensory axones; Q, dividing axone.

Sensory fibers for the heart follow the pathway just outlined, except that they originate in the ganglia on the posterior roots of the spinal nerves. They send axons into the spinal cord by way of the posterior roots.

There is some evidence in favor of the view that vasomotor nerves for the heart originate in the same spinal segments, and are carried by the same pathway as the accelerator and augmentor nerves. This matter is yet to be demonstrated more fully.

**The Pulmonary and Pleural Vasomotors.**—The lungs receive vasomotor impulses from centers rather broadly segmental in localization. The upper lobes are controlled from the upper thoracic centers, the middle from the mid-scapular region, and the lower from the fifth and sixth, perhaps also the seventh, thoracic segments of the spinal cord. The medullated fibers from these centers enter the sympathetic chain, as white rami; they appear to terminate in the ganglia of the upper thoracic and cervical portion of the sympathetic chain. The axons from these ganglia pass partly by way of the vagus and partly by way of the aortic plexus to the blood vessels of the lungs and the pleura. It must not be forgotten that the size of the pulmonary vessels is subject to variations due to variations in the systemic circulation, as well as to direct vasomotor control, and that the effects produced by changes in systemic pressure conditions may be more pronounced than those due to the more direct innervation.

**Control of the Upper Thoracic Centers.**—These centers of the upper thoracic region, those controlling the skeletal muscles of the shoulder girdle, the circulation, the secretion, and the visceral activities of the tissues of the head, face, neck, and thorax, are themselves controlled by impulses from the sensory nerves of the same and adjacent segments of the cord, by sensory impulses from the cranial nerves, and by descending impulses from the medullary, pontine, tectal, ganglionic and cortical centers. Sensory impulses from the skin and superficial muscles affect the functions of these centers to a certain extent; sensory impulses from the deeper muscles, the viscera, and the articular surfaces of the bones related to these tissues affect the centers in a marked

degree. The place of bony lesions of the upper thoracic vertebræ in the etiology of congestion of the eyes, the naso-pharynx, the mucous membranes of the throat, the meninges and all tissues of the head, should not be forgotten. That bony lesions of this area are an efficient factor in the cause of adenoids and nasal polyps is beyond question. The abnormal dilatation of the pupil due to lesions affecting the cilio-spinal center is often a cause of eye strain, and, through the nervous disturbances thus produced, of functional variations in the muscles of accommodation.

The nutrition of the skin and the muscles of the arms and hands may be affected by bony lesions of the upper thoracic vertebræ. Circulatory conditions of the hands, with ocular disturbances, not to be distinguished clinically from the early stages of Raynaud's disease, are found associated with lesions of the fourth and third thoracic vertebræ, and such patients have recovered apparently completely after the correction of the lesions. Weakness and inco-ordination of the muscles, persistent eczemas, recurrent infections, and many disturbances in the shoulder girdle, arms, and hands may be in part due to bony lesions of the upper thoracic vertebræ, the ribs, scapula, or clavicle. When the bones of the upper extremities are broken or dislocated, or when injuries of any kind are present, bony lesions affecting the circulation through the injured parts may retard recovery. The care of all traumatic affections of the upper part of the body should include the correction of lesions of the cervical and upper thoracic vertebræ, and the other bones related to these.

**The Lower Thoracic Group.**—The centers of the lower thoracic group include those lying in the gray matter of the seventh thoracic to the first lumbar segments, inclusive, with probably outlying cells in adjacent segments.

The area of gray matter of the lower thoracic region is rather small. Both the posterior and the anterior horns are long and narrow; the lateral horn is very well developed.

The anterior horn includes the cells only of the mesial group. These send axons to the longissimus dorsi, multifidus spinæ, accessorius, latissimus dorsi, quadratus lumborum, pyramidalis,

cremaster, psoas major and minor, the corresponding intercostal and interchondral muscles, and the abdominal muscles. All of these muscles are easily affected by sensory disturbances initiated either by visceral diseases or by the irritation from bony lesions. They are normally kept in a condition of tone by the normal impulses from these sources, and the abnormal reflexes caused by abnormal sensory stimulation should be considered as merely an extravagant increase in the reflex actions which have so beneficent an effect upon the muscles under normal conditions.

The visceral centers of the lower thoracic group are many. The nerve impulses from these segments to the viscera are carried by about the same pathways in all cases. There are two groups of medullated fibers leaving the spinal cord, and the relationships between these groups is not well known. White fibers leave the lateral horns of the cord by way of the anterior roots, and pass as white rami into the sympathetic chain, where they terminate by forming the pericellular networks around the sympathetic cells. The gray fibers from the sympathetic ganglion cells pass partly by the splanchnic nerves and partly by way of the perivascular plexuses to the viscera and blood vessels. Another group of cells, also in the lateral horns, sends white axons by way of the anterior roots, and these fibers pass directly to the larger sympathetic ganglia in the abdominal cavity, such as those of the solar plexus, etc. The splanchnic fibers terminate in these ganglia, as do the white rami fibers in the lateral chain of sympathetics. It seems true that the white rami and splanchnic fibers all terminate in some sympathetic ganglia and also that not more than one relay occurs between the center in the cord and the structures to be innervated. Any given medullated fiber may branch into fibrillæ, and these may enter into the pericellular baskets around several sympathetic cells, and may even send different branches into different sympathetic ganglia. It is true also that several white fibers may unite in forming the basket around a single sympathetic nerve cell. The great complexity of the functions controlled by way of the lower thoracic centers and the sympathetic ganglia

is thus seen to depend upon an equally complex neuronc relation-ship. The presence of the *vagus* nerves adds further complexities.

**The Gastric Center.**—The paths of the impulses concerned in governing the movements, circulation, and secretion of the stomach have not yet been well worked out. A number of puzzling facts are known concerning the functions of these nerves. The center controlling these functions lies in the fifth to the seventh thoracic segments, with some intrusion upon the fourth and eighth segments. The impulses from these centers are carried partly by the splanchnics, partly by the sympathetic roots of the *vagus*, and partly by the arterial plexus. The functions of these nerves and the centers from which they originate are affected in a marked degree by variations in the amount of carbon dioxide in the blood and probably by varying amounts of other constituents of the blood. The physiological conditions of these structures also appear to cause more marked variations in function on the part of the gastric nerves than is recognized in studying the nervous control of other organs.

Lesions involving the vertebræ, and more rarely the ribs, associated with the spinal segments mentioned are usually found associated with varying degrees of gastrectasis, gastritis, or hyper- or hypo-chlorhydria, and with other symptoms, referable to disturbed nervous control. In the presence of gastric ulcer, cancer, or any structural lesions of the stomach, the reflex muscular contractions in the middle thoracic region of the back are usually painful, and are also an increased cause of abnormal gastric function. The relief of the bony and muscular lesions associated with incurable stomach diseases is often a source of great relief to the patients; the progress of the disease may be hindered, and life is made much easier.

**Centers for Spleen, Liver, and Pancreas.**—The spleen, liver and pancreas are controlled by centers placed in the gray matter of the sixth to the tenth thoracic segments of the spinal cord, with some cells scattered both upward and downward into neighboring segments.



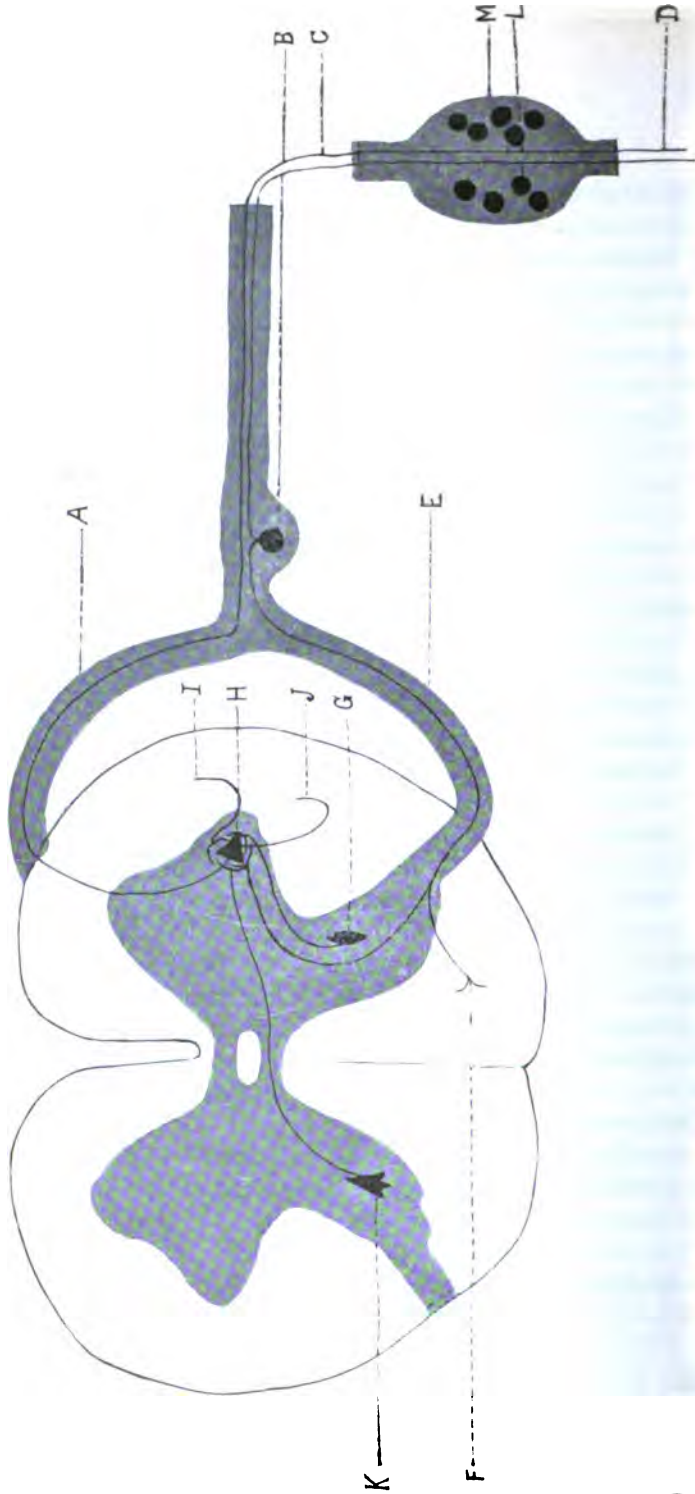

FIG. 65.—CONTROL OF THE SYMPATHETIC NERVES. (Courtesy of Dr. Burns.) A, anterior root, showing only a white ramus fiber; B, sensory ganglion cell; C, white ramus fiber, passing through sympathetic ganglion without interruption; D, effluent ramus from sympathetic ganglion, containing sensory fiber and fiber from lateral horn cell, both medullated; E, posterior root, containing only viscerosensory fiber; F, division of sensory root fiber; G, cell in posterior horn of cord; H, cell in lateral horn of cord; I, descending fiber from medullary center; J, descending fiber of rubro-spinal tract; K, cell of contra-lateral posterior horn; M, cell of sympathetic ganglion. Axones of these cells pass with the splanchnic.

The spleen has its capsular layer of muscle fibers innervated by the upper and middle splanchnic nerves, by way of the solar plexus. Variations in the tone of the spleen, and thus in the circulation of the blood through the abdominal viscera, may be caused by lesions of the vertebræ of the lower thoracic region, especially of the tenth thoracic. The vasomotor nerves for the splenic vessels are carried by the same pathway. The vagus appears to have less effect upon the spleen than it has upon the other abdominal viscera. The enlarged spleen in malaria and in splenomedullary leukemia has been found associated with lesions of the ninth and tenth thoracic vertebræ and with increased sensitiveness and reflex contractions of the deeper spinal muscles innervated from these same segments of the cord.

The liver appears to have all of its varied functions subject to nervous control. The place of the vagus has not been well determined; it is known to exercise some control over hepatic functions. The spinal centers have been shown to modify the secretion of bile, the circulation both of the hepatic and the portal vessels, the formation of glycogen and urea, and the peristalsis of the bile ducts. All of these functions are also, in some degree, modified by impulses carried by way of the vagus nerves, and the entire nervous mechanism of the liver appears to be under the especially efficient control of centers in the medulla.

The nervous control of the pancreas has not been well studied. The experiments upon animals demonstrated increased redness after bony lesions of the tenth, ninth, and sometimes the eighth thoracic vertebræ. Patients suffering from diabetes mellitus have usually had lesions of the tenth and sometimes adjacent vertebræ.

**Centers for Intestinal Control.**—The intestines appear to be controlled by a series of centers which bear a rather roughly segmental relationship to the different parts of the tract. These centers lie in the gray matter of the cord of the ninth thoracic to the second lumbar segments, with a certain amount of intrusion upon the segments adjacent, both above and below. The impulses are carried by way of the splanchnics and the solar plexus,

and partly by way of the aortic plexus. The influence of the vagus should not be forgotten.

The artificial bony lesion in animals under anesthesia is followed by results similar to those found in patients suffering from the effects of bony lesions in the lower thoracic region. These include the formation of rings of persistent contraction in the intestinal wall which are resistant to all ordinary methods of purgation, increased peristalsis, lessened tone of the intestinal muscles, with accumulation of carbon dioxide in greatly increased quantities; pronounced redness of the intestines, with later appearance of venous congestion; and sometimes by reversed peristalsis.

The centers controlling the intestinal movements, secretion, and circulation, may be affected by impulses reaching them from the various viscera of the abdominal cavity, by impulses from abnormal articular surfaces, muscles, or, in less degree, the skin over the corresponding areas of the back and abdomen, and by impulses descending from the medulla, pons, mid-brain, ganglionic centers, and possibly from the cerebellum. The place of emotional disturbances in causing either diarrhoea or constipation is well known. Volitional impulses are not efficient stimuli for the intestines, but volitional impulses may affect the abdominal and lumbar muscles, and the increased tone of these muscles is almost always associated with increased tone, and thus usually with increased activity, of the intestinal muscles.

**The Renal Centers.**—The kidneys appear to act altogether in accordance with the speed of the circulation through them. Secretory nerves have not been demonstrated for them, nor is there any fact in the examination or treatment of patients which gives indication of secretory nerves for the kidneys. The circulation through the kidneys, locally, is governed by centers in the eleventh and twelfth thoracic segments of the cord. These centers appear to be more strictly limited to the segments named than are other spinal centers. The variations in systemic blood pressure are important factors in modifying the secretion of the kidneys, also. Lesions affecting the articular surfaces of the

eleventh and twelfth vertebræ, or the eleventh or twelfth ribs are apt to affect the circulation through the kidneys, and thus to modify the character of the urine. Lesions affecting the systemic blood pressure are also factors in diminishing the efficiency of the kidneys as organs of elimination.

**The Suprenals.**—The suprarenal capsules receive both secretory and vasomotor nerves from the eleventh and twelfth thoracic segments. These centers are not very well understood, but it is known that descending impulses from the ganglionic and probably other higher centers affect the adrenal secretions. Bony lesions of the vertebræ and ribs innervated from the same segment affect the circulation through these glands, and this probably affects also the amount of their internal secretion carried into the circulating blood. Stimulation of the sensory nerves of these segments in human subjects causes a rise of blood pressure which may persist for some hours. In clinic patients the correction of lesions of this region is usually followed by an increased tone of the vascular and cardiac muscles.

**The Reproductive Glands.**—The circulation through the ovaries and testes is controlled by nerve impulses from the tenth thoracic to the second lumbar segments, chiefly by way of the lesser splanchnic nerves, the aortic and solar plexus. These centers are affected greatly by descending impulses from the higher centers, and the impulses thus carried usually affect also the muscles innervated from these segments. The place of erotic literature or thoughts or circumstances in modifying the circulation through the reproductive glands must not be forgotten in the care of patients suffering from diseases of these organs. Bony lesions affecting the vertebræ associated with the ninth thoracic to the second lumbar nerves may seriously impede the circulation through them, and thus may be an important factor in causing or in perpetuating diseases of the ovaries or the testes. The ovaries are more seriously disturbed by abnormal circulatory conditions, chiefly for anatomical reasons.

Secretory nerves have not been demonstrated for these glands, though certain facts of clinical experience seem to indicate that

the internal secretions, at any rate, may be under nervous control. Probably circulatory changes may modify the amount of internal secretions in the blood stream.

**The Lumbo-Sacral Group.**—The centers of the lumbo-sacral areas include those lying below the second lumbar segments. These segments give rise to no white rami fibers, though the *nervus erigens* probably is homologous with the splanchnics.

The lumbar cord is characterized by its short, broad horns, and by the comparatively scanty white matter around the periphery.

The anterior horns, like those of the cervical region, include several groups of cells, whose axons innervate the skeletal muscles of the legs and the pelvic girdle.

The axons of the mesial cell group innervate the *multifidus spinæ*, *interspinales*, *psaos major* and *minor*, *gemelli*, *glutei*, *obturatoris*, *pyriformis*, and the lower parts of the abdominal muscles.

The axons of the cells of the lateral cell group of the anterior horn innervate the muscles of the thigh, leg, foot, and toes.

The location of the cells which supply a number of the pelvic muscles is not yet thoroughly demonstrated. They bear certain resemblances to visceral muscles, in function and in relations, yet they also have some characteristics of skeletal muscles. The phylogeny of these muscles and of their nervous control need much study. The muscles of this type are the *cremasteris*, *sphincters ani*, *levator ani*, *compressor urethræ*, *ischio-cavernosus*, *transversus perinæi*, *sphincters vesicæ*, *sphincter vaginæ*.

The lateral horns of the lumbar cord are wanting or very scantily represented. In the sacral region a cell group probably homologous with the lateral horns of the thoracic region gives origin to the *nervus erigens*.

The posterior horns are short and broad. The sensory ganglia send their fibers as posterior roots into the cord, and the axons of these send terminals and collaterals into the gray matter of all regions. The peripheral fibers of the sensory ganglia of the lumbar and sacral cord are distributed to the skin over the

front of the body below the pelvis, including the external genital organs, and over the back of the body below the crest of the ilium to the muscles and tendons subject to the motor control of these segments; to articular surfaces of all the joints moved by these muscles, and to the viscera controlled by the centers of the lumbo-sacral group.

The motor cells of the lumbo-sacral group are under the control, in part, of the sensory impulses reaching these and adjacent spinal segments; of descending impulses from the medullary and other higher centers; of volitional impulses from the pre-central area of the cerebral cortex of the opposite side; and from the various ganglia in which emotional and instinctive functions are controlled.

Bony lesions of the lumbar vertebræ, of the sacrum, of the coccyx, and of the innominates may initiate sensory impulses subversive of normal activities of these centers. Lesions of the femur, tibia, fibula, patella, and ankle and foot bones are less likely to produce reflex disturbances, though lesions of these bones, being subject to pressure in walking and standing, and being capable of affecting the spinal curvatures, are more often the cause of harmful reflexes than are the corresponding bones of the arms.

**The Ano-Spinal Center.**—The ano-spinal center lies in the lumbar enlargement, it appearing to occupy several segments. Both inhibitory impulses to the anal sphincters and stimulating impulses to the muscular fibers of the lower colon, sigmoid, and rectum are sent from this center, chiefly by the descending association tracts and the third or fourth sacral nerves; or by way of the white rami of the first or second lumbar nerves, the sympathetic ganglia, and the inferior and the hypogastric plexuses. Association tracts also carry impulses which regulate the tension of the intercostals, the diaphragm, and the abdominal muscles. The ano-spinal center is very closely related to the other lumbo-sacral centers, especially those concerned in micturition, erection and parturition.

An important point in the treatment of certain diseases lies in the fact that reflex contractions of the anal sphincters may

result from bony lesions of the sacrum, innominates, and coccyx. Others lesions may also be associated with this condition. The loss of tone of hemorrhoidal veins may depend, in part, upon lesions of the same or neighboring bones. Abnormal sensory impulses from injured pelvic tissues and from diseased tissues in the area of distribution of the lumbo-sacral sensory nerves, may also be concerned in modifying the functions of the muscles of defecation, and of the circulation through the anal tissues and the surrounding structures.

**The Vesico-Spinal Center.**—The control of micturition is by way of about the same paths, and the center is located in the same spinal segments. The enuresis of children, and a lack of bladder control both in children and adults, may be due to lesions of the lumbar and pelvic bones, or to peripheral irritations such as worms, adherent clitoris or prepuce, or any other factor of irritation to the sensory nerves of the same segments.

**The Genito-Spinal Center.**—This center has been demonstrated for male dogs and for men, but no homologous center has been demonstrated for females. Impulses from this center inhibit the activities of other lumbo-sacral centers, and of certain medullary and thoracic centers. The efferent nerves are partly somatic and partly visceral. The somatic nerves pass from the anterior horn cells directly to the skeletal muscles concerned in coition; the impulses for the blood vessels and the visceral muscles concerned probably pass by way of the erection center.

**The Erection Center.**—The center which controls the phenomenon of erection lies in the lower part of the lumbar cord. It appears to be controlled normally by the genito-spinal center, but under abnormal conditions it may act independently. It is more directly under the control of sensory impulses than is the genito-spinal center, but it exerts a less pronounced inhibitory effect upon other centers, at least when it is abnormally and independently stimulated. Bony lesions of lumbar and pelvic bones, abnormal sensory irritations, etc., may cause priapism in adults or may be responsible for abnormal circulatory conditions in the external genital organs. These abnormalities, in turn,

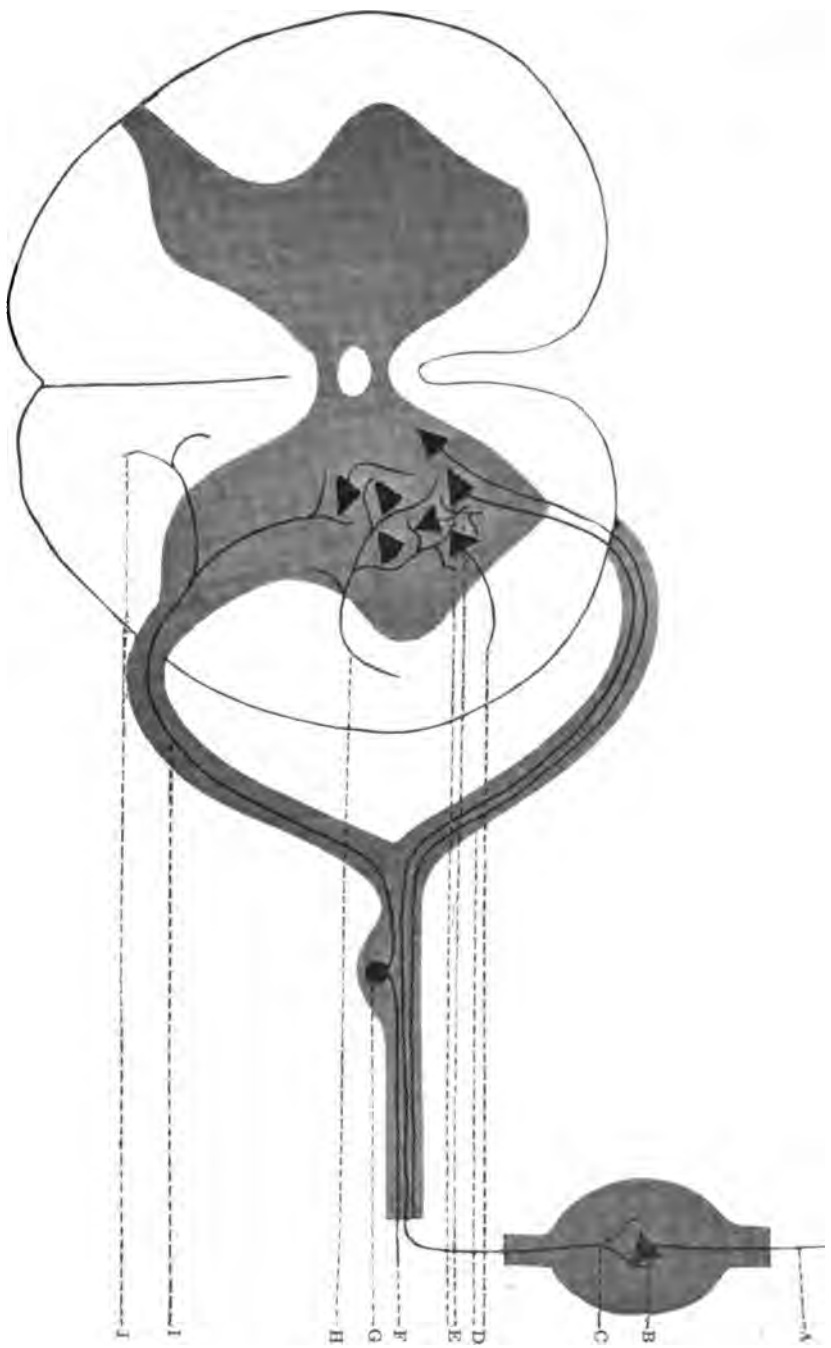

FIG. 68.—ANG-SPINAL CANTER. (Courtesy of Dr. Burns.) A, Gray fiber; B, sympathetic cell of post-ganglionic fiber; C, axon of pre-ganglionic fiber (visceral efferent), arborizing about cell body in sympathetic ganglion; D, efferent fibers; E, cell of efferent fiber; F, sensory fibers; G, cell of sensory fiber; H, descending tract; I, sensory fiber; J, dividing axon.



may be important factors in causing bad habits in children or vicious tendencies in either children or adults.

**The Parturition Center.**—The parturition center appears to be more directly concerned in the regulation and the control of labor than its initiation. It has been found difficult, in experimenting upon animals, to initiate anything like efficient labor, pains before term, or to hasten labor to any great extent, by stimulating the lumbar centers. Slight increase in the process and slight dilatation of the cervix were produced. From the experiments performed it appears that the place of bony lesions in interfering with labor lies more in the disturbed developmental and the nutritional and circulatory conditions than in the actual birth process. This does not, of course, apply to the gross pelvic deformities which offer mechanical obstruction. Experiments in this study are difficult, and much more clinical and experimental evidence is needed.

**Vasomotors for Pelvic Organs.**—The circulation through the pelvic organs is governed partly from the tenth thoracic and neighboring segments (ovaries and testes, especially) and partly from the lumbo-sacral centers. The nervus erigens, from the sacral lateral-horn cells, terminates in the hypogastric plexus, and the gray fibers from these ganglion cells innervate the blood vessels of the lower pelvis and the external genital organs. Reflex disturbances of the circulation through these organs and their neighboring tissues may be caused experimentally by bony lesions in the area of the sensory distribution. Clinically, disturbed circulatory conditions may often appear to be due to these lesions and recovery may occur with no other treatment than the correction of these lesions. These facts should not lead to the neglect of other causes of diseases of these organs.

## CHAPTER L.

### THE PHYSIOLOGY OF CONSCIOUSNESS.

Because of the vast amount of speculation regarding the relationship of mind and body, and because of the failure of mere

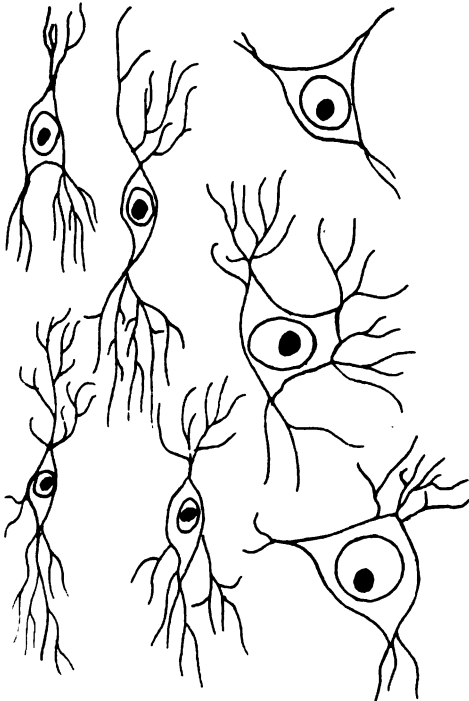

FIG. 67.—Spindle and polymorphic cells from the external layer of the human cortex. These cells are not frequently found in the brains of lower animals, nor in the brains of idiots. They are poorly developed in young children, and are most plentiful and best developed in the overflow areas of the adult human cortex. They are also plentifully found in the olfactory cortex.

philosophical speculations to meet the demands of rational methods of approaching the diagnosis and treatment of mental diseases, a series of tests was begun in the attempt to discover whether or not those phenomena called consciousness might be subject to the same laws as those which govern the physiological relationships of other organs of the body.

The facts already known regarding the activities called consciousness may be briefly given. It is known that, in the human subject at least, the activity of

the neurons of the cerebral cortex is essential to consciousness. The activities of other parts of the nervous system may be essential to the normal condition of the body, but these activities alone are not able to initiate or to modify consciousness. Consciousness is certainly known to be a phenomenon associated

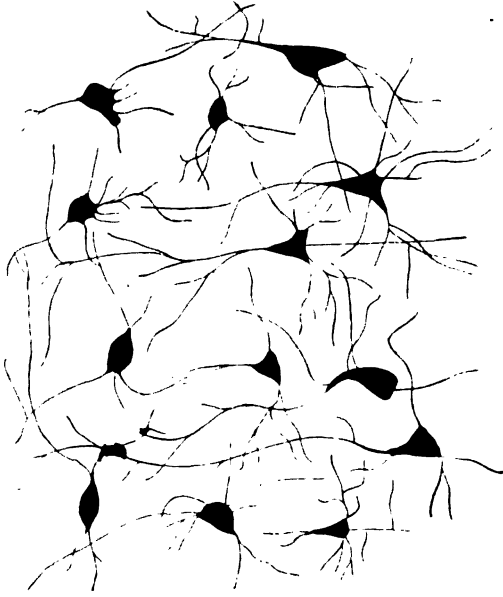

FIG. 68.—Cells from the cortex of the rabbit's brain. 380 diameters. The irregular appearance of the pyramidal cells and short dendrites should be noted.

with the activity of the cortical neurons, and to depend absolutely upon this activity. Of the cortical neurons, there is much evidence in favor of the view that the small cells of the extreme periphery are those most directly concerned in producing consciousness. The neurons of the deeper layers of the cortex are efficient in transmitting and co-ordinating the nerve impulses to and from the external layer, but these appear to be capable of acting independently, without arousing consciousness.

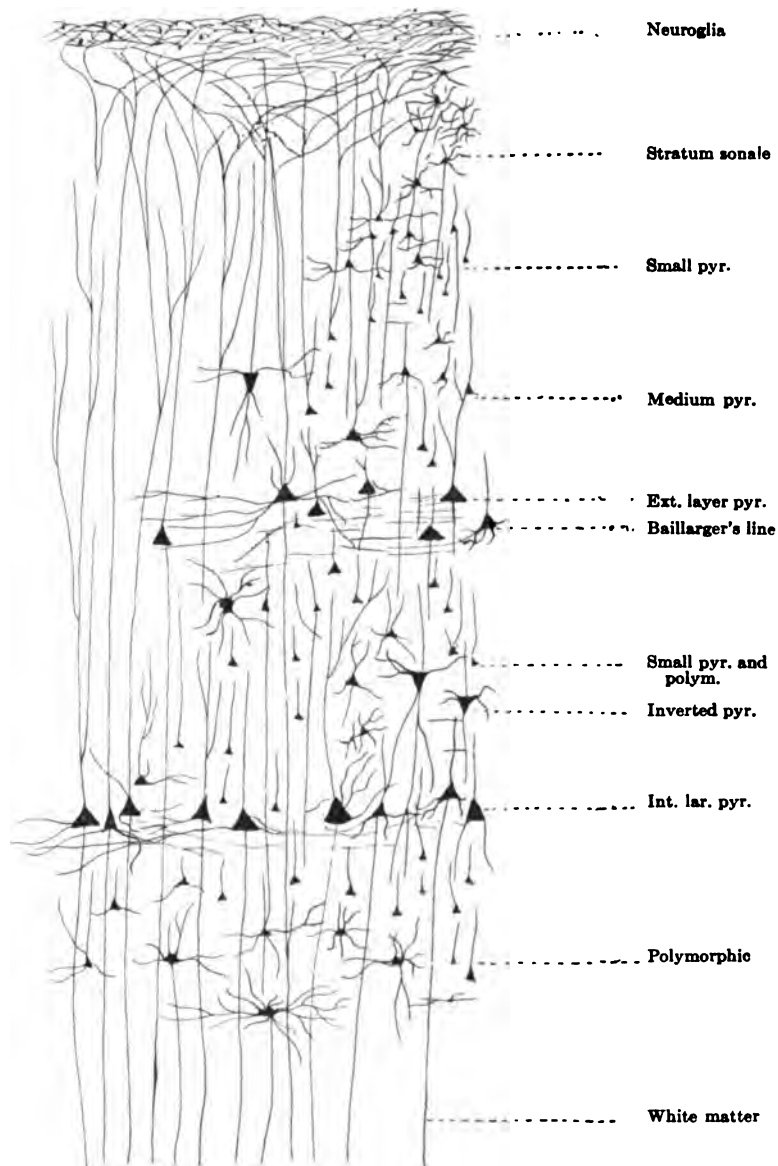

FIG. 69.—Diagram of the layers of the typical cerebral cortex. The neuroglia appears at the external surface. The first layer of the cortex contains the spindle and polymorphic cells. See Fig. 68. Among these cells the dendrites of other cells, and the axones and collaterals of the inverted pyramids of Martinotti branch freely. The layer of small pyramids lies next. The dendrites of these reach the first layer; the axones exhaust themselves branching among the deeper layers. The third layer is characterized by the medium pyramids. The relations of these are as the small pyramids. The fourth layer is characterized by the large pyramids. The axones of these may enter the white matter and pass to other parts of the nervous system. The fifth layer includes small pyramids and polymorphic cells. The sixth layer contains large pyramidal cells, and the axons of these may reach the white matter. The seventh layer contains spindle and polymorphic cells, whose axones also may reach the white matter and pass to other parts of the nervous system. Small pyramidal cells, multipolar cells, Golgi Type II cells, and inverted pyramids may be found through all except the first layer. The line of Baillarger coincides with the external layer of large pyramids.

The different parts of the cortex are known to have different functions in consciousness. Thus, the stimulation of certain areas of the occipital lobe is associated with consciousness of things seen, the stimulation of certain areas of the temporal lobe is associated with the consciousness of things heard, and so on. The structural relationships of the different cortical areas vary according to their varying functions, and the tracts of fibers carrying the nerve impulses concerned in the co-ordination of conscious activities vary according to the functional relationships of the different cortical areas. These statements are made very briefly; they rest upon the facts of experimental evidence, of phylogenetic studies, of series of developing brains, both under normal and abnormal conditions, and of the brains of defectives and of persons suffering from various diseases and mutilating accidents.

The tests performed in the laboratory of physiology of the Pacific College are considered in two series: first, a study of the effects produced upon the bodily conditions by varying conscious states; and second, the manner in which conscious phenomena vary during varying physical conditions.

In both series both normal and abnormal persons were used, and of the abnormal persons some were suffering from functional and some from structural disturbances. Defective children were also included, as well as older persons suffering from diseases of the nervous system. The experiments from which these conclusions were deduced included about five hundred tests.

The "reaction time" is the average time required for the simplest association processes. It was determined by first pronouncing lists of words, in order to decide the pronunciation time both of the subject and of the person who gave the words; then the person making the test spoke the words in order, and the subject answered each word by giving another suggested by the one spoken. The time required for speaking fifty words and answering with suggested words, less the time required for each person to speak fifty words, is the time required for the subject to make fifty associations of a very simple order. The average time required for each association process is the reaction time for the subject under the conditions of the test.

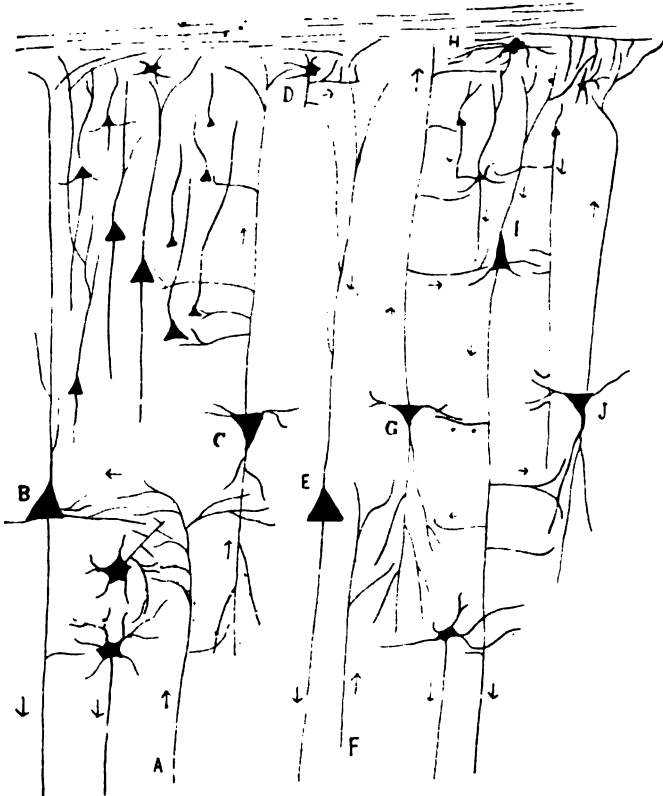

FIG. 70.—Diagram of the elements of the cortex. The arrows show the direction of the nerve impulses. A, incoming axon from other parts of the nervous system; B, large pyramidal cell, which may receive the impulse directly from A, or indirectly by the interpolated neurons. The axon of B may transmit the impulse thus received to other parts of the nervous system, without affecting the neurons of the external layers of the cortex. It is probable that consciousness is not affected by these impulses.

A may transmit the impulses to C, an inverted pyramid of Martinotti, which carries the impulses over its axon to the cells of the stratum sonale, D. The dendrites of either the small, the medium, the large pyramidal cells, as E, may receive the impulses from D, and the large pyramidal cells, as E, may transmit the impulses thus received to other parts of the nervous system.

F, an axon from another part of the nervous system. The impulses carried by F may affect the inverted pyramid, G, which in turn may stimulate the cells of the more peripheral layers of the cortex, including H, a cell of the stratum sonale. The large, small and medium pyramids are affected by the action of H and G, and these affect the cells of the lower layers again. The impulse descending from the stratum sonale may be transmitted to other inverted pyramids, as G and J, and the impulses thus again carried to the cells of the stratum sonale. There is no way of determining the number of times this reaction may occur. It is probable that this series of impulses passing around this circular path is the physiological basis of inhibition, and thus of the mental process of "thinking things over." Ultimately the stimulation of I, a large pyramid, or of any of the cells of the seventh layer, may carry the impulses to other parts of the nervous system, and the final destination of these must be the motor neurons.

For the first series, that is, the study of the effects produced upon the bodily conditions by varying conscious states, lists of words of varying emotional coloring were used. The subject was asked to give synonyms or related terms in answer to the words given him. Fifty words are about the limit of usefulness in these tests, because the normal person involuntarily assumes an attitude of antipathy to the test, and either refuses to continue pronouncing the doleful terms, or finds it difficult to refrain from joking.

The effects produced by the gloomy lists upon normal people are:

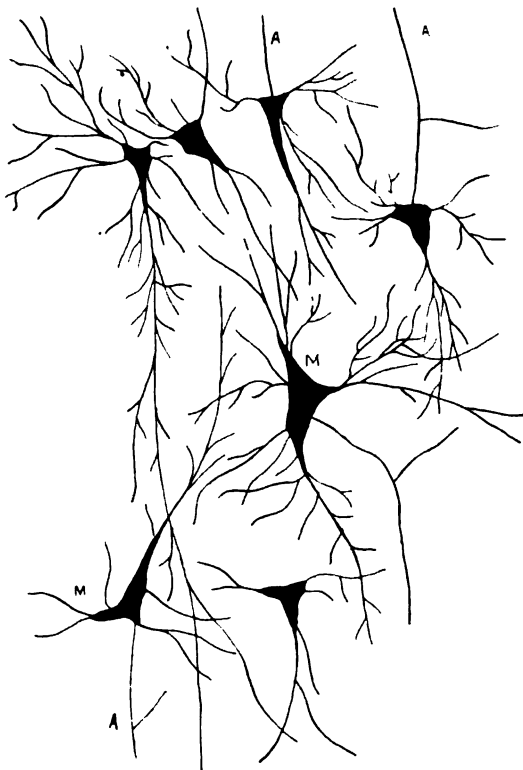

FIG. 71.—Cells from human temporal lobe, about 200 diameters. A, axons; M, inverted pyramids of Martinotti.

Decreased blood pressure, usually 10-15 m. m. Hg, sometimes as much as 40 m. m.;

Decreased pulse rate, with occasional irregularities;

Irregular respiratory movements, with sighing;

Increased reaction time, usually .5 sec.;

Decreased strength in grip, as shown by the dynamometer.

This is most pronounced in the right hand.

The effects of the gloomy lists upon persons of a melancholy disposition were not marked. In defectives and in people with serious diseases of the nervous system no pronounced or constant variations occurred.

Lists of cheerful words were used in the same way. For the most part no effects were observed upon the physiological activities of normal people by the cheerful lists, doubtless because pronouncing the cheerful lists brought no change in the mental coloring of normal people—they are normally cheerful, without any word lists. A few hypochondriac and neurasthenic patients were thus tested. The blood pressure, pulse rate, and muscle strength were all slightly increased by the cheerful lists and the reaction time was slightly diminished in these persons. Mental defectives and persons with serious nervous diseases showed no effects produced by the cheerful lists.

Another series of lists was made up from expressions of inefficiency, such as "lazy," "stupid," "feeble," etc. These ideas produce a slightly diminished muscular tone and the reaction time is increased, but the effects upon circulation, etc., were not so marked as in the case of the gloomy lists.

Lists made up of scientific terms—"solstice," "tangent," "cosine," "molecule," etc.—gave a longer reaction time, sometimes slightly raised the blood pressure, often slightly increased the muscular tone, but had no very great effect upon bodily activities in general.

Lists of words of strenuous significance exert a noticeable effect. Such words as "energy," "violence," "pressure," etc., were used. Increased muscular strength results, the blood pressure goes up, usually about 15 m. m. Hg; the pulse increased



either in rate or force, and the head showed a more erect position, usually.

In some of the tests the subject simply listened to the reading or telling of stories or of articles of varying abstruseness. The variations were, on the whole, rather less marked than when the giving of suggested words made careful attention on the part of the subject an essential part of the experiments.

The manner in which the pulse, respiration, blood pressure, and dynamometer readings varied gave some interesting suggestions as to the use of these tests in diagnosis of certain types of disease. Events which the patient wishes to conceal, or which he considers of no importance, or even which he has forgotten, may affect these physiological activities and thus be brought out by more specific questioning, or may show themselves to the physician, who may find it best to conceal his knowledge for a time. At any event the value of these, or similar, tests in diagnosis must be recognized.

The practical application of all this is fairly evident. Patients should be induced to maintain a mental atmosphere best adapted to their condition. The telling or hearing of accounts of pain or disease must be forbidden the sick, usually; children should not be permitted to hear or to read about, or to see, anything so sorrowful as to affect them seriously; recovery may be hastened, in certain diseases, by securing such changes of work or of climate or scene as are best adapted to the particular conditions.

The manner in which bodily states may affect the mental states was made the subject of the second series. First, the bony lesion was tested.

Subjects who were normal and rested were chosen. Steady pressure at the sides of the spinous processes was, in the first group, used as a test of the effects of the bony lesion. In animal tests this pressure had been found to give the same results as the actual production of a bony lesion, for the most part. The axis, atlas, third cervical, second thoracic, and eighth thoracic were the vertebræ chosen for the experiments. No subject was used for more than one test on any day; all were repeated upon

successive days upon the same subject. When the blood pressure was increased as the result of any given manipulation the reaction time was diminished; when the blood pressure was decreased the reaction time was increased. When word lists of a negative type were used and the blood pressure of the subject had been raised in any way, the tendency was for the greater number of replies to be of a cheerful type; when the blood pressure was lowered and negative word lists were given, the tendency was for the replies to become generally of a more gloomy type.

In a few patients suffering from arterio sclerosis, in whom the blood pressure was already too high, the increasing blood pressure brought increased tendency to gloominess; decreased blood pressure—i. e., approach to the normal—brought increased cheerfulness in the replies. The variations were indicated also in the conversation which sometimes was substituted for the words with answers.

Other findings in a series of experiments regarding the more complex co-ordinations, under other conditions, give the following results:

Fatigue increases the reaction time, and also the proportion of gloomy replies;

Auto-intoxication increases the reaction time;

Fasting decreases the reaction time for one or two days, then increases it. Cheerful replies are increased at first; gloomy replies after the second or third day. This is evident even when the patient shows a very cheerful and merry habit. After urgent mental effort, as a final examination, the reaction time was increased; sometimes it was doubled. The tendency to gloomy replies appeared to depend upon other factors than the fatigue itself.

The practical application in this lies in the recognition of the facts of the case. To a great extent the slow reaction time, the tendency to gloominess and probably to crime, are largely dependent upon the condition of the body. The place of the bony lesions in the etiology of the milder psychoses must not be overlooked. Whether these act directly through abnormal sensory

irritations, or by means of varying blood pressure, or by means of faulty nutrition or assimilation or elimination, or by interfering with the normal production of the blood cells in the marrow of the flat bones, any rational diagnosis and treatment of functional mental disorders must take into account the bony lesions.

# RESULTS OF OSTEOPATHIC RESEARCH.

BY C. A. WHITING, Sc. D., D. O.,  
Pacific College of Osteopathy.

---

## CHAPTER LI.

### OPSONINS.

Opsonin is the name given to a number of substances found in the serum of the blood which act upon bacteria, increasing their susceptibility to the phagocytic action of the white blood corpuscles. Bacteriologists and hæmatologists are now of the opinion that there are at least two distinct classes of opsonins. The first group may be called the natural opsonins. These opsonins are quickly destroyed if they are heated to a temperature of 56° C., and they seem to act upon all or nearly all organisms which may invade the body. The other group of opsonins may be spoken of as the specific opsonins. These are not destroyed by heat at a temperature under 60° C., and they appear to be produced by the body in direct response to specific stimulation. They are only capable of opsonizing the special bacteria whose irritation has led to their production. Experience shows that when bacteria are opsonized by a special opsonin they are equally susceptible to leucocytes drawn from widely different sources. For example, if bacteria are opsonized by a given blood serum, leucocytes from well people, or from people suffering from various diseases, and leucocytes taken from some of the other warm-blooded animals, all seem to have about the same phagocytic power. On the other hand, if different emulsions of bacteria are opsonized with different sera it is found that these emulsions are acted upon very differently by phagocytes taken from the same source. From

what has been said, it will be noted that opsonins act solely on bacteria and that they have little or no effect upon the phagocytes. Within certain limits, the opsonic index may be used both as a means of the diagnosis and of the prognosis of disease. It is sometimes a very difficult matter to differentiate between a tubercular infection of organs like the kidneys, liver, spleen, etc., and a syphilitic infection of these same organs. If the infection is tubercular it is almost always true that the opsonic index of the patient is low, whereas if the infection is syphilitic his index to the *Bacillus tuberculosis* remains substantially normal. If in treating a tubercular case the opsonic index remains comparatively low, it is usually an indication that the patient is passing into a chronic tubercular condition, whereas if the opsonic index rises to normal, or a little above, it is a very good indication of his probable complete recovery. The early workers with the opsonic index believed that the only method of increasing the index was by using attenuated vaccines of the organism from which the patient desired to be protected, but we now know that anything which promotes good circulation and good digestion, or in other words, anything which tends to increase the health of the individual, raises the opsonic index.

A series of experiments conducted at the Pacific College of Osteopathy showed that the mechanical stimulation of the liver and spleen produced in almost every case a marked increase in the opsonic index. This series of experiments seems so conclusive along this line that we present the results in this place:

Nov. 2	Index .98	four hours after stimulation	...1.4
Nov. 8	Index 1.1	four hours after stimulation	...1.3
Nov. 30	Index .99	four hours after stimulation	...1.1
Dec. 6	Index 1.2	four hours after stimulation	...1.2
Dec. 14	Index 1.	four hours after stimulation	...1.4
Dec. 21	Index 1.1	four hours after stimulation	...1.3
Jan. 12	Index .99	four hours after stimulation	...1.1
Jan. 27	Index .95	four hours after stimulation	...1.
Mar. 9	Index 1.2	four hours after stimulation	...1.2
Mar. 23	Index 1.	four hours after stimulation	...1.2
April 13	Index 1.1	four hours after stimulation	...1.4
April 21	Index 1.	four hours after stimulation	...1.3

Since this work was done experiments have shown that moderate exercise produces the same effect. If the exercise is

prolonged to the extent of marked fatigue, as is the case after a day spent in mountain climbing, there is a period of twenty-four hours—a little more or less—during which the opsonic index is lowered. This, however, is followed by an increase in the opsonic index, and the increase continues for between one and two days. The increase in the opsonic index following physical manipulation is of short duration and does not appear to continue for more than six or eight hours. This may be regarded as an indication that osteopathic treatments in cases of acute diseases should be frequent, and the failure which some physicians have experienced in dealing with pneumonia, diphtheria, and other acute diseases may be quite as much due to an excessive length of time between treatments as to any inefficiency of the system which they practice.



# SECTION XI

---

DR. DEASON'S RESEARCH  
WORK





## CHAPTER LII.

# SOME PHYSIOLOGICAL EFFECTS OF VERTEBRAL MOVEMENTS EXPERIMENTALLY PRODUCED.

(The original report was published in full in the *Journal of Osteopathy*, Apr. 1911.)

J. DEASON.

### EXPLANATORY NOTE.

The following is a report of the research work done by Dr. Deason and his assistants. The work for the most part has been done in the laboratories of the American School of Osteopathy under the general direction of the A. T. Still Research Institute, with the exception of the first six series, which were done at the author's expense without financial assistance from the Institute. The Institute deserves credit for the greater part of the work done by other workers who have reported their results in the foregoing pages of this part of the book, as it has financially assisted in much of the work.

The different series of work recorded in the following pages have been reported in full in *The Journal of Osteopathy* and *The Journal of the American Osteopathic Association*, and only summaries of the work are given here. Some of the series have not yet been completed and some pertain to other subjects than physiology, therefore the explanation of the missing series. Twenty different series of original experimental work have been done and the reports of the missing series will be ready for publication in the near future. In this work more than six hundred animals have been used. The author is greatly indebted to the student assistants in the American School of Osteopathy for their help

in this work, and many deserve credit whose names do not appear in connection with the different series as reported.

### SERIES NO. 2.

In this series of experiments the purpose has been to determine the relation of perverted positions and abnormal movements of the spine to structural perversions and abnormal movements of other parts of the body, and to determine the physiological effects resulting from such operations.

**Methods and Technique of Experiments.**—Much care has been exercised in the selection of animals for these experiments. Dogs were used, because blood pressure and pulse tracings can be more readily obtained from these than from smaller animals, and no animal was used which had not been kept for a sufficient time under normal conditions to determine that it was entirely devoid of any abnormalities which might render the results valueless. The spine was carefully examined in each case, to determine that no bony lesions existed before proceeding with the operations.

Reasons for the above precautions will be better understood when the reader is reminded of the fact that the average dog is frequently found suffering from constitutional diseases, many of which are traceable to spinal lesions, the evidence of which statement we hope to bring out at some future time. (See series Nos. 4, 9 and 12, which were published later.)

It is a well-known fact to all workers in physiological research that not all animals exhibit average normal functions when operated on under anæsthesia. It is necessary, therefore, to experiment on several animals, and take the average results of those which seem to display the most normal reactions under the anæsthetic used. Thus the need of examining the spine of each animal used will be readily apparent. The following results have been taken from a common average of ten animals operated upon.

During the operations the animals were kept under complete and regular anæsthesia by ether, which was administered by means of a tracheal cannula, as it is most satisfactorily regulated

in this way. Blood pressure and pulse tracings were taken from the carotid artery by the use of a carotid cannula and mercury manometer.

Respiratory tracings were taken from the side arm of a T tube, connected on the one hand to the tracheal cannula and on the other to a diaphragm tambour, which was made to record on the smoked paper of a revolving kymograph simultaneously with the blood pressure and pulse tracings mentioned above. An electric signal magnet, connected with an inductorium and metronome, was used to record time and furnish a base line.

Several normal blood-pressure and respiratory tracings were taken from each animal before any tests were applied, to determine whether or not the animal was showing normal functional activities. From five to ten minutes were allowed before and after each test for normalization. All results from animals whose tracings failed to show normal activities before any tests were applied were discarded.

**Preliminary Test to Determine Relation of the Position of the Animal to Blood-Pressure Variations.**—The caudal end of the animal was elevated, thorax remaining on the table, to determine blood-pressure variations thus effected. Extreme tilting of the body, such as lifting of the caudal end or relative lowering of the cephalic end, brings about a marked increase in blood pressure, due to the effect of the force of gravity, but in the above operation, in which only a part of the animal was lifted, the increase in blood pressure was not great, seldom exceeding two millimeters of mercury; nor was the result a lasting one, as the pressure returned to normal within ten or fifteen seconds after replacement of the caudal end upon the table. The animal was then placed in different positions, such as ventrum on operating board, dorsum on operating board, and changed from side to side, and the blood pressure, pulse and respiratory variations, as recorded on the kymograph, were noted. The variations thus produced were not great, but were carefully noted for comparative purposes. \* \* \*

**Functionally Different Spinal Areas.**—In the above series of experiments we have observed that different areas or regions of the spine seemed to produce different functional effects from these perverted positions and pressures, but as yet little work has been done experimentally, so we urge that it be not accepted as conclusive. From the work which has been done it would seem safe to say that spinal pressure in many ways simulates spinal movements produced with fixation, always varying the blood pressure, usually the respiration, and frequently affecting changes in heart rate and amplitude.

It is evident that such pressures have wholly different effects on blood pressure and rate of heart beat when produced in different areas of the spine, possibly affecting the so-called spinal centers.

**Summary.**—While this series of experiments, as has been stated above, is only preliminary, and cannot be taken as final, enough work has been done to show quite conclusively that certain movements of the spine, normal and abnormal, and especially those in which fixation was employed, are much more effective in producing functional variations than movements or massage of other parts of the body. (By fixation we mean the localization of movement. One vertebra is fixed, holding it either by the transverse or spinous process, producing a localization of movement at the point fixed.) In the future we hope to offer some suggestions on the possible physiological explanation of this, which will be based upon experimental evidence.

That these changes cannot be accounted for by gravity effects we think is sufficiently evident from the preliminary tests made, and because of the precautions observed to avoid it, as have been described.

That the massage effects could not possibly be responsible for these changes is clearly shown by the nature of the effects produced in that way. Massage when vigorously applied to any part of the body does produce blood pressure, pulse and respiratory variations, but in all cases, even when continued for a much longer time than the time given to the spinal movements and pressures, the results are not so great or of so long duration, but quite

conversely returning to normal almost immediately after the massage was discontinued. While the blood pressure and respiration are usually slightly increased, the amplitude and rate of heart beat are usually unaffected. Massage, in its effect upon animals under anæsthesia, therefore, is almost wholly incomparable to movements of the spine with fixation.

The effects of movements of the spine without fixation are very similar to passive movements of other parts of the body. There is always an increase in blood pressure and respiration, but usually no noticeable variations in heart rate and amplitude, and the variations are of short duration as compared to movements of the spine with fixation. Even when hyper-extensions and hyper-flexions were employed the changes so effected were not at all comparable to changes caused by these movements with fixation.

The effects of movements of the spine with fixation, localized movement at some one point, causing an excess of movement or partial temporary subluxation, seemed to be most effective in the production of functional variations, blood pressure and respiration being affected in all cases, and in many instances the heart rate and amplitude of heart beat being also affected.

**Conclusion.**—From the results of this series of experiments we have arrived at no hasty conclusion in stating quite definitely that of all the different tests which we have described above, those movements which affect the spine in such a way as to produce conditions comparable to the osteopathic bony lesion are the most efficacious in producing abnormal variations in certain vital physiological processes, as have been described.

Granting that this be true, it does not seem unreasonable to conjecture that other functions, such as peristalsis, secretion, metabolism, etc., would be similarly affected.

CHAPTER LIII.

SERIES NO. 3.

**ON THE PATHWAYS FOR THE BULBAR  
RESPIRATORY IMPULSES IN THE  
SPINAL CORD.**

BY J. DEASON AND L. G. ROBB.

The work on this series was done in the Hull Physiological Laboratory, University of Chicago, and in the physiological laboratories at the American School of Osteopathy.

Original report was published in the American Journal of Physiology, April 1, 1911.

The experiments summarized in this report were carried out at the suggestion of Professor Carlson with the view of testing out a possible explanation of the Porter experiment on the spinal respiratory pathways.

On repeating the well-known Porter experiment with a group of students in advanced physiology of the central nervous system, Professor Carlson found that after hemisection of the cervical cord and section of the opposite phrenic nerve in young kittens the respiratory impulses do not cross the median line in the cord if the animal is in a state of depression at the time of section of the phrenic. In such an animal, however, dyspnoea induces crossing of the impulses. Dyspnoea also leads to crossing of the impulses without previous section of the opposite phrenic nerve. This would seem to show that the crossed pathways for the respiratory impulses are normally open, and that their use depends upon the relative intensity of the impulses discharged from the bulbar center.

The crossing of the respiratory impulses in the Porter experiment may be:

I. A case of opening up of new reflex paths. The chief objections to this explanation are that the crossing takes place practically instantaneously on section of the opposite phrenic; and that dyspnoea induces the crossing, without the section of the opposite phrenic.

II. The section of the phrenic may raise the excitability of the phrenic and the bulbar respiratory centers, and thus increase the intensity of the respiratory impulses. In this case the Porter experiment becomes simply a special case of the spread of the reflex (or automatic) responses *pari passu* with the increased intensity of the stimulus (or the nervous impulses).

The second hypothesis demands that the phrenic nerves contain afferent fibers, whose stimulation increases the intensity of the respiratory impulses; and that the crossing should be induced by the stimulation of any sensory nerve that causes an increase in the intensity of the bulbar respiratory discharges. \* \* \*

### RESULTS.

**Confirmation of Porter's Experiment.**—In all of our experiments it was found that after hemisection of the cord in the upper cervical region (second or third segments) the diaphragm on the side of hemisection was paralyzed, and provided the animals were in good condition, section of the opposite phrenic nerve immediately started the respiratory rhythm in the diaphragm on the side of the hemisection, followed by a permanent paralysis of the diaphragm on the side of the sectioned nerve.

Porter assumes that "the section of the phrenic nerve interrupts the ordinary respiratory pathway on the same side, and a greater portion, perhaps the whole descending impulse of that side passes through the crossed dendrites to the phrenic cells of the opposite side." Unless the passage of the bulbar respiratory impulses from their spinal conduction paths to the cells of origin of the phrenic motor fibers depends in some way on the normal impulses of afferent fibers in the phrenic; or unless the mere section of the phrenic motor fibers by antidromic impulses immediately



blocks the passage from the spinal conduction paths to the phrenic cells, there is no reason for assuming such an "overflow" of the impulses to the opposite side.

The crossing of the bulbar respiratory impulses at the level of the phrenic nuclei after hemisection of the spinal cord can be induced by traction on the phrenic nerve of the intact side of the cord. The traction need not be great enough to block the impulses in the nerve. In fact, if it is properly adjusted, a uniform respiratory rhythm is induced in both sides of the diaphragm.

Stimulation of the sciatic nerve induces crossing of the respiratory impulses and an equal contraction of each lateral half of the diaphragm, which may continue for ten minutes after the cessation of the stimulation.

#### SUMMARY AND CONCLUSIONS.

1. The phrenic nerves contain afferent fibers, the stimulation of which augments the intensity and the rate of the bulbar respiratory impulses. The effects of stimulation of these fibers on the respiratory center outlasts for varying lengths of time the period of stimulation.

2. After hemisection of the spinal cord between the medulla and the phrenic nuclei and consequent paralysis of the diaphragm on the hemisected side, the bulbar respiratory impulses will cross from the intact to the hemisected side of the spinal cord on stimulation of the sciatic nerve; on traction or mechanical stimulation of the phrenic nerve on the intact side of the cord; in dyspnoea; as well as on section of the phrenic nerve on the intact side. These various conditions induce increased intensity of the bulbar respiratory impulses. The immediate crossing of the bulbar respiratory impulses on section of the phrenic nerve after previous hemisection of the opposite side of the cervical cord seems therefore to be a case of the spread of reflex (or automatic) responses *pari passu* with the increased intensity of the nervous impulses. But since in the Porter experiment the crossing of the impulses appears to be permanent, additional factors are probably involved.

## CHAPTER LIV.

### SERIES NO. 4.

# RELATION OF SPINAL LESIONS TO CARBOHYDRATE METABOLISM.

J. DEASON, D. O.

A Report on the Fourth Series of Mammalian Experiments, from the Physiological Laboratories of the American School of Osteopathy; published in the Journal of the American Osteopathic Association, June, 1911.

The original purpose of this series of experiments was to determine the relation of the spinal bony lesion to carbohydrate metabolism. Later, however, several other problems have arisen, such as the relation of these lesions to nutrition, normal functions of the stomach and intestines, gastro-intestinal infection, etc.; therefore some preliminary notes will be offered on these subjects in the summary of this article.

### LITERATURE.

In reviewing the literature of the experimental work which has been done on the relation of the pancreas and other organs to carbohydrate metabolism, we find the following to report: It would seem that here as well as in most other functional disturbances that not only one, but in many cases, several structures are involved, and considering, as all physiological experimenters now well understand, the fact that MANY, OR POSSIBLY ALL, ORGANS OF THE BODY BEAR A CERTAIN ESSENTIAL FUNCTIONAL RELATIONSHIP WITH EACH OTHER, WE CAN SEE HOW A DISTURBANCE OF THE FUNCTION OF ONE STRUCTURE MIGHT EASILY AFFECT THE FUNCTIONAL ACTIVITY OF ANOTHER.

That either direct or indirect interference with the nerve supply to the pancreas and other related structures plays an important part in the production of glycosuria, we offer the following evidence from the literature:

**Effects of Total Extirpation of the Pancreas.**—Pfluger believes that the fact that glycosuria which follows the extirpation of the salivary glands and the thyroid glands is generally attributed to the nervous phenomena would warrant a careful consideration of nervous elements in pancreatic glycosuria. After a consideration of the cases of partial extirpation of the pancreas cited in the literature, Pfluger concludes that in those cases where glycosuria occurred the cause lay in the nervous disturbances. All, or practically all, of the investigators agree that after partial extirpation of the pancreas glycosuria is exceptional rather than general. Pfluger attributes the results of J. Thiraloix, who holds that there is invariably glycosuria resulting after partial extirpation, to poor technique in the removal of the pancreas and accompanying injury or violent stimulation of the nerves. Likewise, in H. Luthjes's experiments, Pfluger places the source of glycosuria in the white gangrene resulting from the cauterizing and which is undoubtedly a violent irritant to the nerves. Pfluger's own colleague Wetze, never found glycosuria to result after partial extirpation of the pancreas in dogs except in the case of one female which was suffering from acute peritonitis.

Pawlow has shown that the pancreas is innervated by the vagus. E. Kulz claims that stimulation of the central end of the cut vagus leads to glycosuria. E. Cavazzani's work tends to show that stimulation of the celiac plexus causes sugar synthesis in the liver. The number of ways in which nerve stimulation may affect the metabolism of the carbohydrates is many. Claude Bernard maintains that the puncture of the floor of the fourth ventricle in the rabbit is followed by a transitory form of diabetes, the so-called Pique diabetes. This is known as the diabetic area. Pfluger says: "It is hardly to be doubted that there is a complicated nervous mechanism regulating the sugar metabolism much in the same way as the heart is regulated by a complex nervous

system." Minkowski finds that in dogs and other mammals complete extirpation leads to the severest forms of diabetes mellitus. In other animals he found the same to be true, which has been verified by nearly all workers on this problem.

Pfluger, in experimenting on frogs, produced diabetes after removal of the pancreas in all but one case. He says that failure to obtain glycosuria after total extirpation is due to the blood supply of the liver being very intimately connected with the pancreas and hence it is difficult to remove all without injuring the liver. If such a relation between the liver and the pancreas exists (and we find nothing in the literature which questions it) these two organs as well as the stomach and duodenum should bear a certain functional relationship with one another. Marius got diabetes in twelve frogs out of nineteen experimented upon. Gaupl also believes that the negative glycosuria in frogs upon removal of the pancreas, as reported by Minkowski, is due to its intimate connection with the liver.

Pfluger in one paper advances the theory that two antagonistic powers regulate the sugar content of the urine. One is the function of the nervous system and has its center in the medulla. This power may cause a rise in the sugar content of the urine. The storing of glycogen in the liver depends partly upon this center. From all parts of the organism centripetal nerves pass to this center so as to regulate the needs of the organ. The force is a chemical or anti-diabetic force of a substance secreted in the pancreas. By some unknown force it hinders the formation of sugar in the blood. Bernard and Eckhard have determined that the sugar center for metabolism lies in the medulla and works through the splanchnic area on the production of sugar from glycogen. As long as any part of the pancreas is alive it must have a central nervous connection by means of the fine network of nerves along the blood vessels supplying blood to the pancreas.

There seems to be sufficient reason for accepting this nervous mechanism by way of the splanchnics, but whether they are secretory, trophic, regulatory, or perform their function by regulating the blood supply has not been determined. Pfluger argues that

the pancreas has a direct connection with the sugar center and consequently with the liver and duodenum. Evidently the glandular substance must play some important part in the sugar metabolism, as diabetes results immediately on the removal of the last small part which previously had prevented the diabetes. In this way the excessive formation of sugar is counteracted by the action of the secretion of the pancreas to form an anti-diabetic ferment.

Partial extirpation, that is, from the head or tail of the gland, leaving from one-third to one-fifth of the organ, gives the foregoing results, but the quantity of gland remaining is not as necessary as its state of nutrition, blood supply, and innervation. (This fact, taken from the general physiological literature, is of great osteopathic importance. The function of any glandular structure varies directly, as its blood and nerve supply, a part of the gland itself may be removed without in many cases any marked perversion of functions, but nerve and blood supply are of greater importance.) Minkowski found glycosuria to be very slight in one case where he had left a part of the gland the size of a pea. In this case, on feeding protein the sugar disappeared in the urine but reappeared on carbohydrate diet. Minkowski and Sandmeyer have observed cases of incomplete extirpation in which a slight glycosuria appeared which gradually reinforced itself and grew to a severe case of diabetes. This evolution comes about from a degeneration of the glandular elements after atrophy of the fragments of the gland remaining from the partial extirpation. According to Minkowski partial extirpation gives three results, viz.: First, absence of diabetes; second, diabetes of a light form; third, a light form of diabetes which gradually becomes severe. IT WOULD SEEM, AND IN FACT IT IS STATED BY SOME OF THE MOST EXPERIENCED WORKERS, THAT IT IS THE INTERFERENCE WITH THE BLOOD AND NERVE SUPPLY AND NOT THE LACK OF GLANDULAR TISSUE WHICH CAUSES THE GLYCOSURIA IN PARTIAL EXTIRPATION.

**Relation of Pancreas and Liver.**—According to Cheveau and Kaufman, the pancreas is coupled with the liver in relation

to glycogen formation. The formation of sugar from glycogen is increased after extirpation of the pancreas, and the amount of sugar used by the body remains the same. The sugar content of the blood is the same before or after the animals have been rendered diabetic. Section of the cord below the bulb, whether alone or combined with extirpation of the pancreas, causes diabetes and, according to Cheveau and Kaufman, there are two centers in the bulb influencing the formation of sugar from glycogen. These two centers are acted on by the internal secretion of the pancreas in an opposite way. The inhibitory center is excited and the excitatory center is inhibited. The extirpation of the pancreas destroys the action of the inhibitory center and activates the excitatory center, thus causing the formation of sugar from the glycogen.

The internal secretion exercises a powerful retarding action on the disintegration of the tissues. Over-production of sugar from the liver is the cause of pancreatic diabetes. First, from a disturbance of the nervous mechanism regulating the hepatic glucose formation; second, by direct action on the liver (suppression or a moderating action which produces the internal secretion of the pancreas, which acts directly on the hepatic-glucose formation); and third, from histological disintegration, a larger amount of that material passes into circulation which is apt to form sugar in passing through the liver, i. e., a suppression of the moderating action of the pancreas on that substance.

Cutting the vagi and splanchnics has been found by Von Graefe and V. Henson to produce temporary glycosuria. The same kind of glycosuria is obtained by cutting the lower cervical ganglion. In four or five hours a maximum diabetes is reached. Traces may be found for even twenty-four hours. Eckhard obtained slight glycosuria upon cutting the upper chest ganglion of a sympathetic nerve. Dr. Emil Canazzani has done some interesting experiments upon the celiac plexus. He stimulated the nerves to the liver, electrically, and obtained a decrease in the amount of glycogen in a few moments and an inverse in sugar content. Two dogs were experimented upon, the stimulation

being kept up for from five to fifteen minutes. In the first dog the glycogen was 1.67%, and after stimulation was .77%. The other dog showed 3.94% before, and 2.30% after stimulation. How does this affect the formation of antibodies in the pancreas?

If the vagus is stimulated in the neck the stomach and oesophagus contract while the peristalsis of the intestine is apparently not affected, yet we know that the vagus exerts a power over the intestines. Many have stimulated and obtained no secretion of the pancreas or stomach, yet Pawlow has conclusively proven that. So far it has been contended that the plexus of the duodenum controls the secretion of antibodies in the pancreas.

Now it is to be proved that the duodenum does not have an internal secretion which helps to form the antibodies. Hedon grafted a piece of pancreas into a dog. This piece was connected with the peritoneum through nerves and blood vessels, then the entire pancreas was removed. Later the connection with the mesenteric nerves and blood vessels was cut and no diabetes resulted, hence the duodenum cannot form antibodies and does not influence the pancreas excepting when there is a nervous connection. This is of no immediate value to us in presenting the argument set forth in this article other than to show the nervous relationship existing between the duodenum and pancreas.

**Transplantation.**—Hedon transplanted part of the pancreas under the skin and then removed the remaining pancreas. In this case no diabetes resulted, but when the grafted portion was removed diabetes immediately became evident and sugar was found in the urine. He says that few cases in which the above is not the result can be attributed to the outgrowth of the grafted pancreas upon the wall of the abdomen and the failure to remove this outgrowth. Sbolew, Minkowski, Thiraloix, Pfluger, and others, by similar experiments have partially confirmed these results.

**Feeding or Injecting of Pancreatic Extract.**—If the pancreas produces a substance which aids sugar metabolism it would seem possible and necessary, in order to prove this secretion, to obtain from the extirpated pancreas a substance which

upon injection into a diabetic animal would prevent the excretion of glucose in the urine. In 260 cases performed by Hedon there have been few results on injection of this pancreatic extract. Capparelli, however, with the same procedure, found that the sugar secretion was lessened in three hours and in most cases it completely disappeared. But Pfluger contends that in his experiments there seems to be some doubt as to whether he had removed all of the pancreas. Experiments by many prove that feeding the pancreas of cattle increases the sugar from three to four times the normal amount.

**Other Methods of Causing Glycosuria.**—Minkowski says that sugar elimination may be caused first by eating much sugar (alimentary glycosuria), that is, flooding the organism with it; second, by rapid changing of glycogen into sugar by the liver, causing an increase in the blood and consequently sugar in the urine; and third, by the administration of certain drugs. In pancreatic extirpation the oxidation of sugar is disturbed, while the drug causes sugar elimination without disturbing oxidation of the sugar. It causes the kidneys to take the sugar from the blood and secrete it, thus causing the percentage of sugar in the blood to fall below normal. It is thus shown that increased elimination of sugar in the urine can be caused in other ways than by disturbance of the function of the pancreas. It would seem from this that any interference with the innervation or nerve supply to the pancreas, liver, or duodenum might effect at least a low percentage of glycosuria.

**Proofs of Internal Secretion.**—As long as there is no other proof at hand than that which has been advanced so far, the theory of internal secretion must stand. Hedon has taken the sterilized extract of pancreas and injected it in large doses intraperitoneally and intravenously, without checking the diabetes. He found that the injection of water or glycerin extract of pancreas intraperitoneally always produced a large amount of pus, even though the greatest care was exercised. If the extract was filtered through a medicated candle, hard knots appeared in place of the abscess and these were gradually absorbed. Hedon



thinks the candle removes the protein and enzymes. After this filtration large amounts may be injected intravenously without killing the animal. Pfluger tries to disprove the theory of Minkowski that pancreatotomy retains the toxins of the liver, by transfusion of blood from a diabetic animal to a healthy one without producing glycosuria in the healthy dog.

**Chemical Stimulation.**—Diabetes may be produced by chemical means. Certain substances such as phloridzin and uranium salts, are capable of producing a severe glycosuria, which has been thought to be due to the detrimental action of these substances on the kidney cells. Coincident with this type of glycosuria there is a diminished sugar content in the blood. Various other substances, such as carbon dioxide, adrenalin, ether, chloroform, morphine, curare, veratria, pyrogallol, salicylatis, pilocarpin, amyl nitrate, and potassium cyanide, possess the property of inducing glycosuria, and as far as has been investigated, according to Underhill, an accompanying hypoglycemia has been noted. Obviously, he says this type conforms more closely to the true diabetes. Harter has shown that glycosuria is usually readily produced by painting the pancreas with piperidin or by intraperitoneal injection. At times this sugar elimination is very marked and may persist for several hours. Again the glycosuria is very slight or may be entirely lacking, even though large doses of the drug have been given. Piperidin was selected by Harter as he thought it a typical representative of a number of drugs which produced glycosuria. In the case of piperidin glycosuria as studied by Harter, two attempts were made to determine whether it was accompanied by hyperglycemia. In neither of these experiments was the sugar content of the blood changed, and the suggestion was made that the renal factor is associated with this form of glycosuria. These experiments have been repeated by Underhill and the influence of piperidin applied to the pancreas with the following results: In three experiments by painting the pancreas with 5 c. c. of 4% piperidin he got only an average increase of .07% of sugar in the blood. This appears contrary to Harter's results mentioned above, but not so much

of an increase when we recall that probably .04% of this amount obtained might have been due only to the anesthesia, leaving possibly .03% actually produced by the painting of the piperidin. These results also present variations of as much as .09%, and no two of them check closer than .03%, so that the inaccuracy of such results is plainly evident. In reviewing the tables of experiments performed by Underhill, Scott, and others, we find that in many cases the glycosuria is lacking. This may be explained by the fact that small or insufficient doses of the drug were given, and hence the increase in sugar content of the blood was not sufficient to cause elimination by the kidneys. Hedon, Gley, and Thiraloix have caused a profound degeneration and atrophy of the pancreas by injection of various substances without causing a trace of diabetes. Advocates of the internal-secretion theory maintain that under the foregoing conditions small portions of the pancreas probably escaped degeneration. On the other hand, adherents to the nervous theory fail to conceive how microscopic remnants could so thoroughly regulate sugar metabolism.

**Relations of the Islets of Langerhans and the Zymogenous Tubules in the Pancreas.**—After inanition, in some animals at least, it has been shown by Statkewitsch that there is a material increase in islet tissue. This statement has been confirmed by Vincent and Thompson, and also by Dale. There are rows of epithelial cells separated by very large expanded capillaries, as in the thyroids. They thus present a very large surface to the blood stream. Between these rows of cells can be differentiated at times very fine granular substances which are afterwards extruded into the lumen.

From the above it will be seen that much work has been done in an attempt to determine the various causes of glycosuria and hyperglycemia. The results of these workers are so much at variance that it is indeed difficult to arrive at any definite conclusion. That the nervous system has at least a regulatory influence upon carbohydrate metabolism seems to be conclusively settled. That the blood supply to the pancreas also plays an important part seems quite probable in that it effects a greater

or lesser functional activity by the quantity supplied, and by association of various organs through internal secretions. That the pancreas produces an internal secretion which is essential to carbohydrate metabolism has also been established.

### **RELATIONS OF THORACIC BONY LESIONS TO CARBOHYDRATE METABOLISM.**

It has been our purpose in this series of experiments to determine the relation of thoracic bony lesions on similar functions. Drs. McConnell and Farmer have done work on the relation of spinal lesions to functional disorders. They have found that spinal lesions in some cases, at least, are accompanied by glycosuria but the greater part of their work has been along other lines. So far as we know, nothing has been done with this one purpose in view.

From the osteopathic texts we find the following: "I have found variations from the normal generally beginning with the ninth dorsal. I carefully examine and adjust every section of spine to the sacrum and coccyx, also the eleventh and twelfth ribs on both sides. These variations act powerfully on the excretory system and excite and irritate the solar plexus, which gives off branches to the abdominal excretory system." (P. 401, *Osteopathy—Research and Practice*, by Dr. A. T. Still.) "Almost invariably there will be found a posterior dorso-lumbar curvature wherein the spinal-column tissues are much contracted. This condition probably involves the sympathetics (vasomotor and trophic), to the pancreas, liver and intestines." (*Practice of Osteopathy*, McConnell and Teall.)

It would seem logical that if the bony lesion produces functional errors in the cord or splanchnic fibers, either or both, that these disturbances should interfere with the nervous mechanism which, as has been pointed out above, regulates certain functional activities governing carbohydrate metabolism, errors of which bring about certain functional disturbances, such as glycosuria and hypoglycemia. That spinal bony lesions produce marked

variations in blood pressure has already been demonstrated in our mammalian experiments, Series No. 2. (See page 510.)

The results of continued lesions on blood pressure have not as yet been determined by experiment, but judging from the results of the work that has been done we find that lesion in, or pressure on, the mid-dorsal produces an increase in blood pressure by vaso-constriction. Now we know that over-stimulation results finally in inhibition, which would mean vaso-dilation and an increase in blood supply to the parts innervated by the nerves from this region of the spine. This would mean a greater amount of blood than the veins could normally carry away, and therefore a congestion of the parts which in turn would mean a temporary increase, followed by a decrease, in function. We know that the functional activity of most secreting glands varies directly with their blood supply. The ability of the gland to produce internal secretion normal in quantity and quality should also be affected by any interference with its nerve or blood supply. Therefore, considering that the pancreas produces an internal secretion which performs an important function on carbohydrate metabolism, this would be materially affected by the spinal bony lesion if our reasoning is correct.

**Experimental Methods Employed.**—Many things were to be considered in the study of functional effects. The normalization or the selection of normal animals is always first, for obvious reasons. Dogs were the animals used, because they may be more easily managed and will furnish sufficient urine for examination. Healthy dogs of medium age were used, as these are more likely to be normal. Each dog was kept from one to four weeks before being caged. It was usually necessary to feed the dogs regularly for a time to get them in good condition and accustomed to the new environment. If, after this preliminary test, the dogs seemed normal they were then placed in a cage and their physical condition was more carefully studied.

This cage, built of iron bars, was thirty inches wide, thirty high, and eighty long. Each cage was divided into two compartments separated by a sheet-iron partition, and stood twelve

inches from the floor. The floor of the cage consisted of heavy screen wire resting upon iron bars, which allowed the urine to pass through and be immediately separated from the feces or other material from the dog's body. Beneath the screen floor a zinc pan was suspended which served to collect the urine and drain it into another container. The door of the cage consisted of one entire end hinged in such a way that it might be removed. All parts of the cage were made so that they might be removed for cleaning and sterilizing. These cages were painted, that they might be more easily cleaned and to prevent iron-rust contamination in the feces and other material to be examined. The cages were washed clean with hot water and brush, and sterilized with boiling water and steam twice daily. The containers used for collection of urine were cleaned and sterilized at the same time. Six such cages were used, accomodating twelve animals at a time.

**Care of the Animals.**—After the animals selected had been kept long enough to determine that they were in good physical condition they were given a soap bath in warm water and a thorough scrubbing with a brush, followed by a cold shower, and placed in the cages for normalization. Samples of urine were then taken twice daily and qualitative and quantitative analyses made.

**Normalization of Dogs.**—After being thoroughly washed, each dog was carefully weighed (a special pair of scales being used which were sensitive to 25 grams), and placed in a separate cage and left for from eight to twelve hours, after which time the nature and consistency of the feces were noted and the urine tested. The dog was fed and watered and given exercise by allowing it to run about on the campus, or when the weather was too bad they were allowed to run free in the room. The cages were again cleaned and sterilized with boiling water and steam and the feet of the dogs washed before returning to the cage. Once or twice each week the dog received a soap scrubbing and shower bath. A regular mixed diet was given twice daily, the amount of food and water taken each day being noted. If the dog, after being

kept under such circumstances for a period of from two to four weeks, showed no abnormal symptoms and its urine was free from sugar and was otherwise normal, and if the dog gradually increased or remained constant in weight (dogs will usually show a constant increase in weight when kept under such conditions), it was considered normal and ready to be tested. Before lesioning each animal was etherized, usually two or three times, to determine the effects of the anesthetic on the functional activities of the dog, and particularly its relation to production of sugar in the urine. (Some animals show a slight glycosuria, from .03% to .1% after administration of ether.) The animal was then left for a few days longer and, if no abnormal symptoms developed, was lesioned.

**Methods of Producing Bony Lesions.**—The dogs, after normalization, were placed under complete ether anesthesia, which was maintained until the lesion was produced. Traction to the spine was first applied by pulling upon the caudal end while the anterior part of the body was held. After stretching, the lesion in the thoracic region (mid- and lower dorsal) was produced by rotation with fixation, one individual holding the vertebra by pressure on its spinous or transverse process while another rotated the caudal end of the animal. As soon as a marked subluxation could be palpated the animal was released and placed in a normal position and the vertebræ again palpated. It is no easy task to produce a permanent bony lesion in a healthy dog, as they often adjust themselves while coming out of the anesthesia, or within a few hours after the operation. Often the same lesion must be produced from three to six times before it remains, and in a few dogs we were never sure that we got a permanent bony lesion. (After more experience and study the work of lesioning in our later series became much easier.) This fact in itself, however, is no argument against the existence of the bony lesion in man, because of the anatomical differences between the dog's spine and the human. The dog's spine is so different in many respects that it makes necessary a careful study of its particular anatomy before any tests may be successfully tried.

**Care of Dogs after Lesioning.**—After lesioning, the animals were placed in their cages and watched until they had recovered from the anesthesia. The care after lesioning was the same as given above under "Normalization," except that they were not exercised for a day or two after the lesion was produced. This was done to prevent accidental correction of the lesion from vigorous exercise. Two rooms were used for the dogs, both of which were supplied with steam heat which could be well regulated, hot and cold water, and steam for sterilization and good ventilation. The floors were scrubbed every day and everything kept in a sanitary condition, to maintain good environmental conditions. One room was kept for the cages, the other for a "playroom" where the animals could take regular exercise. During spare time twenty students were kept busy for a period of thirteen months caring for these animals, analyzing the urine, etc. Only two dogs were given to one student at a time. A daily record of the general condition of every animal was kept in a ledger as follows: Weight, diet, amount of food and drink, nature of feces, etc., to which was added the urinary findings.

**Post-Mortem Examination.**—After a permanent lesion had been produced the dogs were kept from two weeks to seven months under the above described condition. After a good record had been obtained the dogs were killed by the use of chloroform and placed immediately upon the operating table, ventrum down. The skin was laid open the entire length of the spine and laid back. The superficial appearance of muscles and fascia was carefully inspected in the presence of other members of the faculty. The entire spine was then removed, the ribs being clipped off two or three inches from the spine, which was then examined as to its general contour, curvatures, specific subluxation, etc. In some cases deep dissections were made, but usually it was placed immediately into fixing solution and given to a pathologist, together with specimens of the viscera for pathological examination. This part of the work has not as yet been completed and therefore we cannot report on the findings at this time.

**Results.**—It has been suggested that such lesions as we claim to produce experimentally could either not be produced and made to remain as permanent subluxations, or they would be complete luxations, in which case there would be trauma to the cord and the effects would be produced in this way. That permanent subluxations can be produced experimentally on animals has been conclusively proven by the work of Drs. McConnell and Farmer and verified by the results of this series of experiments. That these lesions were not luxations which could cause any trauma to the cord is evident from the many post-mortem examinations which have been made by Drs. McConnell and Farmer and by the work reported in this article. That the subluxations which we have produced do not produce their effects by pressure or trauma to the cord is evidenced by the fact that none of our lesioned animals has ever developed the slightest paralysis or other symptoms of trauma to the cord.

### SUMMARY AND CONCLUSION.

The above results have been given very briefly, for space would not permit a complete description of the physical condition and urinary findings. Thirty-three animals were used in all, but only fifteen of these could be sufficiently well normalized to be used for lesioning. It is obvious that control work in such a series of experiments is absolutely necessary, or the results would be valueless. In order that we might know that the effects obtained were not due to the diet given or to any environmental condition, only six of the animals were kept lesioned at one time, the others remaining normal. The normal animals therefore furnished controls against the lesioned animals. All of these animals were controlled against themselves, "normalized," and also controlled against other animals before and after lesioning. This insured that the results obtained were not due to accidental causes. There were never any functional disturbances resulting from the diet given or from the conditions under which these animals were kept.



Each of the fifteen animals which were normalized, out of the thirty-three used, showed some functional disturbances from the lesions produced. These disturbances varied from a slight abnormality in urinary findings, which probably would never have caused any serious trouble, to conditions sufficiently severe in nature to cause death. (Animal No. 4.)

Glycosuria appeared or was increased in every animal lesioned, varying in amount from a trace to 5%. That this condition was a permanent functional disturbance is shown by the fact that in animals kept from three to seven months after lesioning the percentage of sugar either remained constant or increased in amount during the entire time, except in animals in which the lesions were accidentally corrected.

Either constipation or diarrhea followed lesioning in eight out of fifteen dogs used. In some cases this was only mild, but in four animals, Nos. 4, 9, 10, and 11, this was of a severe type. Gastro-intestinal disorders resulting in vomiting, etc., occurred in five animals.

A severe vaginal infection appeared in one animal (No. 10), which cleared up when the lesion was corrected. A few of the animals which would not normalize were dissected to determine if a bony lesion could be found that might explain the cause. In most cases either specific subluxations or curvatures were found. This part of the work was left to be investigated by the pathologist.

In conclusion it would seem safe to say from the above results that we believe that spinal bony lesions, particularly those in the mid- and lower dorsal, bear some relation to carbohydrate metabolism and the occurrence of sugar in the urine; that there seems to be some relation between these lesions and constipation and diarrhea and possibly stomach and intestinal disorders. It would also seem possible that these lesions might in some way predispose to infection. We are undecided as to the effect of these (mid- and lower dorsal) lesions on nutrition. In most cases, for the first few weeks, at least, there was no loss of weight following the lesion, but in nearly all cases after being kept for

from two to four months, in some instances in less time, the animal began to show trophic disturbances and loss in weight; but it would be unsafe to say with any definiteness that the loss of weight was effected by the lesion produced.

We have often been asked if we attempted any correction of these lesions that caused functional disturbances. We have not tried this, as it was our purpose only to determine whether such lesions would produce functional disturbances in perfectly normal animals—and we believe they do. The results of this series have been briefly but definitely stated just as they were found. Physicians who read this report will be well able to interpret the results in each case, therefore no lengthy conclusion is necessary.

## CHAPTER LV.

### SERIES NO. 5.

# SOME SPINAL SYMPATHETIC REFLEXES.

L. G. ROBB, D. O.

(From the Research Department of Physiology, American School of Osteopathy.)

It was our purpose in this series of experiments to try to gather some information on certain physiological questions which seem to bear some relationship to certain osteopathic principles. The work is a continuation of our first series of mammalian experiments, which we hope to present more fully at some future time.

**Problems.**—Does the sympathetic system react to the stimulation of all typical spinal and cranial sensory nerves? Is there any special reaction for the stimulation of these nerves? If so, what is this reaction and what conditions may influence it; if not, where may we expect the reaction?

**Results.**—In a few cases stimulation of the sciatic with the splanchnics intact either failed to stop or initiated a peristalsis. In these cases distinct bony lesions were noted in the dorsal region of the spine. Some dogs having lesions in this area did not react thus, but gave the normal inhibition. After section of one splanchnic in dogs that reacted normally the results were variable. In most cases a feeble peristalsis of the stomach would start at varying intervals, to be lost before reaching the pylorus; in others a distinct peristalsis would be started which continued for a short time after removal of the stimulus. In normal dogs with both splanchnics cut, stimulation of a sensory (sciatic or cord of brachial) nerve caused peristalsis in the stomach (reflex over the vagus) which was generally continued on to the duodenum. Stimulation

of the intact vagus with a weak induction current for 30 to 60 seconds decreased the latency period and increased the strength of the peristaltic movement reflexly excited, which previously was impossible to elicit or had been very weak. The latency period, character and duration after removal of the stimulus, showed great individual variation. I observed in three cases with the splanchnics intact what I took to be a reverse peristalsis. The contractions were vigorous, beginning at the pylorus and progressing rapidly to the cardia.

**Conclusion.**—1. Stimulation of the central end of a spinal or cranial sensory nerve equals in effect stimulation of the peripheral end of some sympathetic nerve or nerves.

2. The visceral (sympathetic sensory) afferent fibers appear to be particularly efficient for vasomotor reflexes.

3. There are special (habit) reactions for the stimulation of some afferent nerves, but this specificity may be changed to a general reaction by anything that will decrease or interrupt the irritability or conductivity of the efferent element.

4. Internal environment may open up other so-called specific reflex paths.

5. Anything which increases the irritability and conductivity of the efferent element increases its reflex response. This increase may be both qualitative and quantitative.

6. Normally the general reflexes have a tendency to bring about passive (inhibitory) reactions.

7. Other conditions being equal, there is a tendency for homonymously related segments to respond.

## CHAPTER LVI.

SERIES NO. 7.

# OSTEOPATHIC STIMULATION AND INHIBITION.

H. L. COLLINS AND CHAS. R. EITEL.

(Published in the Journal of A. O. A., July, 1912.)

This work was suggested by Dr. Deason for the purpose of determining whether the so-called osteopathic stimulation and inhibition effects, as claimed by some physicians, could be demonstrated upon animals and also for the purpose of doing some control work on mammalian Series No. 2 done last year by Drs. Deason and Robb.

It has long been claimed by members of the profession that osteopathic manipulation, such as vigorous movements of one or more of the spinal segments either alone or with deep manipulation of muscles are stimulatory in nature, meaning that such changes as increase in heart beat, both rate and amplitude; increase in blood pressure, increase in body temperature, and, in fact, an increase in many or possibly all functional activities controlled by nerves from these segments may be effected, and that its effects be directed to certain body organs. The theory claims, also, that by deep and well-regulated pressure applied to the spine a diametrically opposite effect, or inhibition of the functions of those structures supplied by nerves from the segments pressed upon, may be produced.

On the other hand, there are those physicians who claim that neither stimulation nor inhibition results from osteopathic treatment, but that it is only a normalization; that is, if an osteopathic lesion of any type, bony or otherwise, exists which is responsible

for perversion of function, the correction of this lesion will result in a normalization of the function. Thus, if the lesion has caused a decreased functional activity of a certain organ, this functional activity will be raised to or toward the normal after the lesion is adjusted; and if the functional activity is increased by reason of the lesion, it will be reduced to normal upon readjustment of the structural condition.

By the above definition we do not refer to the question of osteopathic inhibition (pressure) applied over areas of the body rather than spinal regions. That pressure applied over certain nerve trunks and visceral structures will result in the reduction of pain and other functional disturbances has been demonstrated by clinical experiences of many osteopathic practitioners.

It has been sufficiently demonstrated (Series Nos. 1 and 2) that the pressure results were not due to massage, but to pressure stimulation alone; for although in cutaneous and deep muscular-pressure stimulation slight variations in blood pressure, heart rate, and respiration were usually, though not always, produced, they returned to normal as soon as the stimulation was discontinued while in direct pressure stimulation of the spine the blood pressure remained increased for several minutes after the stimulation was removed. (Fifteen dogs were used in this series and detailed reports were given in the results of the original description of the work.)

The above results relative to stimulation and inhibition have been reported in detail on seven of the animals for the purpose of showing the reason for the following conclusions:

1. That osteopathic manipulation to the mid- or lower cervical and upper dorsal regions causes an increase in blood pressure and as a rule a slight increase in rate and amplitude of heart beat.
2. Osteopathic manipulation when applied to the mid- and lower dorsal or lumbar regions produces a reduction of systemic blood pressure, while the respiration and heart beat remain unaffected or are slightly increased.

3. We have not been able to demonstrate in this series of work that there is any essential difference between osteopathic stimulation and inhibition when applied to the same area of the spine.

4. That osteopathic manipulation or inhibition when applied to spinal regions, and which do not effect a correction of any structural perversion, are not always followed by specific effects.

5. That osteopathic manipulations when applied to various regions of the spine are neither specifically stimulatory nor inhibitory unless by such treatment a correction of some structural perversion is effected.

6. In most animals all kinds of manipulative treatment are to some extent stimulatory in nature, except pressure which is applied over nerve trunks or over the so-called "peripheral centers" for long periods of time. This may be explained by the law, "over-stimulation equals inhibition," but we question if this applies to manipulation of the spine.

7. That treatment of a certain spinal area in most cases is followed by physiological effects which depend upon the function of the nerve supply of structures innervated from these spinal segments; as, for example, the almost constant increase in blood pressure obtained from manipulation of the lower cervical and upper thoracic region. It may be argued that the quite constant results obtained from certain so-called inhibitory treatments, such as that used in diarrhea, would tend to conflict with the results given above, but we would remind the reader that the function of the splanchnic nerves to the intestines is normally that of inhibition to the peristalsis, and therefore decreased peristalsis would result from stimulation rather than from inhibition.

## CHAPTER LVII.

### SERIES NO. 9.

# SOME IMMEDIATE EFFECTS OF DORSAL LESIONS ON VISCERAL REFLEXES.

L. G. ROBB, D. O.

While working on "movements of the alimentary canal" with the various classes \* \* \* I noticed an occasional animal whose reflexes were diametrically opposite to what had been designated as normal—i. e., a reflex inhibition of peristalsis as a result of stimulation of a peripheral spinal nerve. In seeking an explanation of this I examined the spine and invariably found a lesion, or lesions, in the splanchnic region, more likely at the seventh, eighth, or ninth dorsal, although some were above and some below this.

These lesions were generally in the form of rotations (an occasional scoliosis was found) and rather pronounced—i. e., were visible after removal of the skin and fascia and were easily reduced in the dead animal.

**Problems.**—1. May a spinal lesion affect the normal spino-sympathetic reflexes; if so, does it inhibit or accelerate the action of the region involved?

2. Is this action constant?

3. Is only one or are all functions of the involved nerves affected?

**Lesions.**—The animals in all cases (fifteen animals were used) were first normalized, then while the anesthesia was deep, traction was applied to the caudal part of the body with the cephalic end fixed, or vice versa, then the body flexed and rotated with the point of lesion fixed.



**Results.**—It must be borne in mind that only the immediate effects of the lesion are dealt with in this article.

**Summary.**—1. Stimulation of the central end of the sciatic or branch of the brachial plexus after lesion (rotation) in the mid- or lower dorsal region causes a peristalsis in the stomach and a minimal rise in blood pressure, which may or may not stop on removal of the stimulus. If a peristalsis is already progressing this stimulus will increase its amplitude.

2. Production of a lesion is sometimes sufficient to produce a persistent spontaneous peristalsis.

3. An anti-peristalsis is occasionally observed, which is apparently due to an action of the splanchnic nerves.

**Conclusion.**—An acute lesion will affect the normal spino-sympathetic reflexes. This action is inhibition to the function of the parts involved.

The fact that a reverse peristalsis was obtained in some cases and the same effect, preceded by a vaso-constriction and viscerodilation, was produced by stimulation of the peripheral end of the splanchnic nerve, would lead one to think that this might affect all or only a part of the functions of the nerves involved, or, if such a thing be possible, a perverted action of the involved nerves. This action is surprisingly constant, although it varies greatly in degree.

## CHAPTER LVIII.

### SERIES NO. 10.

# SOME IMMEDIATE EFFECTS OF BONY LESIONS UPON VASCULAR REFLEXES.

J. DEASON and C. L. DORON.

The purpose of this series was to determine the effect upon dorsal and lower cervical lesions upon: Blood pressure; rate and amplitude of heart beat.

**Methods Employed.**—Animals used: dogs, nine; cats, two. Anesthetic, ether given by means of a tracheal cannula, and in all cases deep and constant. The sciatic nerve was sectioned and stimulation applied to the central end by a medium faradic current. The blood pressure was taken from the carotid or femoral arteries by the usual manometrical method. Respiration was taken from a tambour attached to the tracheal cannula by a T-tube. Normal tracings were taken on all animals before they were lesioned.

Lesions were made by traction and rotation of the cephalic end, with the lower cervical or upper dorsal fixed. Most lesions were in the sixth and seventh cervical, the dorsal lesions being difficult to obtain and make permanent.

**Literature.**—Very little or no literature can be found on this subject, since only a comparatively small amount of work has been done along these lines. This series bears the same relation to vascular reflexes that series No. 9 does to visceral reflexes.

**Results.**—As has been proven many times, stimulation applied to the central end of the sciatic or any mixed or sensory nerve causes an increase in respiration, heart beat, and blood

pressure. The following is the table of the results obtained upon blood pressure and rate and amplitude of heart beat by stimulation applied to the central end of the sciatic:

BEFORE LESION.			
Animal No.	Rate	Amp.	Blood Pressure
1 Dog	Inc. 10%	Inc.	Inc. 7 m. m.
2 Dog	Inc. 10%	Inc.	Inc. 6 m. m.
3 Dog	Inc. 2%	Inc.	Inc. 2 m. m.
4 Dog	Dec. 4%	Inc.	Inc. 4.5 m. m.
5 Dog	Dec. 2%	Dec.	Inc. 13 m. m.
6 Dog	Inc. 2%	Same	Inc. 9 m. m.
7 Cat	Inc. 2%	Inc.	Inc. 9.5 m. m.
8 Cat	Inc. 2%	Inc.	Inc. 6 m. m.
9 Dog	Inc. 10%	Inc.	Inc. 8.2 m. m.
10 Dog	Inc. 4%	Inc.	Inc. 4 m. m.
11 Dog	Same	Same	Inc. 4 m. m.
Average	Inc. 2.9%	Inc.	Inc. 6.6 m. m.

AFTER LESION.		
Rate	Amplitude	Blood Pressure
No change	No change	Dec. 9 m. m.
Inc. 8%	No change	Inc. 2.5 m. m.
Inc. 1.8%	No change	Dec. 2 m. m.
Inc. 2%	Increase	Dec. 15.5 m. m.
Inc. 2%	No change	Dec. 9 m. m.
Dec. 1%	No change	Dec. 9.5 m. m.
No change	No change	Dec. 7.2 m. m.
No change	No change	Dec. 4 m. m.
Inc. 9%	No change	Inc. 3.5 m. m.
No change	No change	Dec. 6 m. m.
No change	No change	Dec. 2.6 m. m.
Inc. 2.3%	No change	Dec. 5.3 m. m.

It will be noted from these results that before the lesion was caused the blood pressure was increased by stimulation to the central end of the sciatic, this increase ranging from two to 13 m. m., with an average of 6.6 m. m. After lesion was produced the same stimulation caused a decrease in blood pressure except in two cases. This decrease ranged from 2 to 15.5 m. m., with a general average of 5.3 m. m. In the first of the exceptions (Dog No. 2) the increase in heart beat was excessive, yet the blood pressure did not increase as much as before the lesion. In the second case (Dog No. 9) the heart beat was less than before lesion, but not enough to account for the change in blood pressure.

The rate of heart beat after lesion was not materially increased except in two instances. The amplitude, which before lesion was

increased by stimulation, showed no increase after lesion except in one case, and that was very slight. All of these results were obtained within thirty or forty minutes after the lesion was made. After that time the normal function was regained. When a subluxation was obtained that was permanent the normal functions were not regained. These were only obtainable in small dogs. When a greater strength stimulus was used after the lesion than before, normal functions were obtained.

**Summary.**—Stimulation of an afferent or mixed nerve caused a fall in blood pressure and a decrease in heart rate and amplitude with a bony lesion in the region of the cardio-autonomics.

**Conclusion.**—The above results corroborate the findings obtained in Series No. 9; i. e., an acute lesion will affect the normal spinal sympathetic reflexes. This action is an inhibition to the functions of the parts involved. That the fall in arterial pressure was not due entirely to the rate and amplitude of heart beat can be seen from the results obtained. Stewart states (sixth edition, pages 167-8) that freezing of the cord in the lower cervical region causes a marked fall in blood pressure due to loss of vaso-constrictor tone. May this decrease in blood pressure, as a result of an osteopathic lesion, not be caused by the block of the vaso-constrictor fibers in this region, causing a loss of tone in the artery walls and a corresponding fall in blood pressure? It is also possible that the stimulus, failing to be communicated to the heart and blood vessels through the nerves of the lower cervical and upper dorsal regions, reaches these structures by way of the vagi, retarding the heart action and causing a vaso-dilation.

**Effects of Osteopathic Lesions Artificially Produced, Not Due to Spinal Shock.**—It has been suggested by certain research workers in physiology in the medical schools that the results obtained from the produced lesions in animals by osteopathic workers might be due to spinal shock. The physiological meaning of "spinal shock" is that there are certain well-marked and far-reaching disturbances of the central nervous system which result from trauma to or partial or complete section of the spinal cord. There is no reason for discussing here the various

theories of spinal shock, but we shall try to show that the results obtained by us could not be explained by this phenomenon.

1. The osteopathic lesion affects particularly the nervous system supplying visceral structure (spinal autonomies). The skeletal musculature being less often affected, just the opposite to this occurs in spinal shock; viz., the skeletal muscles are most often involved. Sherrington states as follows:

"It is noteworthy that spinal shock takes effect on just those tissues which waste when the synaptic nervous system is destroyed, namely, the skeletal muscles. When the primitive diffuse nervous system, the nerve-net, exists as in the visceral and vascular musculature, neither spinal shock nor atrophy occurs consequently to spinal transection \* \* \* and after total transverse section of the cord in man the depression of function of skeletal musculature is profound and practically permanent. On the other hand, the depression of visceral function seems hardly greater in man and the ape than in rabbit or frog."

2. Quoting again from Sherrington, "The shock takes effect almost exclusively in the aboral direction," which fact has been corroborated by most workers on this subject. On the other hand, the effects of osteopathic lesion may and, as a rule, will, involve structures on either or both sides (cephalic and caudal to the point of vertebral separation) equally.

3. Spinal shock materially affects the blood pressure, causing a marked decrease, and destroys the vasomotor reflexes. Sherrington states: "When in the dog complete transection of the spinal cord through the eighth cervical segment is practiced, a severe fall in general arterial blood pressure ensues, and vasomotor reflexes cannot be elicited."

The effects of the bony lesion produced in this area (see Series Nos. 2 and 8) are, as a rule, just the opposite to this, viz., that an increase in blood pressure and often an increase in rate and amplitude of heart beat result. The production of the lesion, that is, the possible effect or effects of manipulations used by us or the "strain" on the nervous system following these manipulations, could not be due to spinal shock because no marked fall in

blood pressure has ever been found, and the vasomotor reflexes are never completely destroyed. The fact that lesion or "spinal strain" in some areas of the spine produce an increase in blood pressure, while in other areas the opposite effect is produced, and the fact further that no such effects are obtainable from spinal shocks, again differentiates them.

4. Paralysis, partial or complete, of certain muscles or groups of muscles, according to the extent of the lesion, is common in spinal shocks. This is not true of osteopathic lesions. Of all the animals operated in this laboratory (about 140 dogs, cats, and monkeys), not a single animal has ever shown any signs of paralysis. There was often tenderness about the affected part, but no symptoms of direct injury to the cord, and therefore no symptoms comparable to spinal shock. Extreme care was always exercised to not produce complete luxations, and there was never a case of bony fracture, ligamentous tear, or complete luxation produced from our attempts to produce subluxations or what may properly be termed osteopathic bony lesions. We have, of course, not obtained functional disturbances from every attempted lesion, but by far the greater number of such attempts have followed by functional disturbances, and this could not have been due to spinal shock.

5. The blood pressure effects from spinal bony lesion last several minutes, after which (if the lesion is only a spinal strain, i. e., if it is not a permanent subluxation) it returns to normal. This effect is somewhat similar to spinal shock, except that the time necessary for normalization is much longer. If the shock is due to complete transection, several days are necessary for recovery. It might be argued that because the higher animals, man included, are more susceptible to spinal shock, and recovery occurs slower, in the human the effects which we hold as being results of bony lesions could be due to spinal shock. This, we believe, is hardly tenable, for the following reasons:

6. In case of spinal shock, recovery of the structures supplied by the autonomic nervous system (visceral structures) occurs, which varies directly with the time and inversely with

the phylogenetic developmental stage of the animal in question. On the other hand, as a rule, the effects of a permanent bony lesion increase with time. That is, in case of lesions of long standing the perversion of physiological effects and the extent of pathological change is also increased.

7. SPINAL SHOCK AND SPINAL STRAIN.—Since the phenomena of spinal shock are insufficient, what is the explanation of perversion of certain physiological functions following slight subluxations of vertebræ and other joints? With the experimental information which we now have at hand it is safe to say that subluxations due to trauma, muscular contractions, decreased tone in ligaments and muscles about the joint, etc., may be capable of producing widely different effects. The first, the subluxation due to trauma, is comparable to the artificial bony lesion, and this we may say produces its effects by spinal strain. By spinal strain is meant the effects on the nerves in the immediate relation with the joint or joints involved. The stretching or compression of the joint structures might, by mechanical stimulation to either the efferent or afferent nerve elements, produce an increased activity of these fibers or nerve trunks. This, if the perverted structural relations are not permanent, would be temporary and a corresponding temporary inhibition or decreased functional activity of the nerve elements would follow, which lasts for varying lengths of time, after which normal functional activities of the nerves may be demonstrated. The fact that a temporary increase in blood pressure, etc., followed by a decrease, usually follows such manipulations tends to substantiate this theory. This explanation alone, however, is hardly sufficient for a complete explanation of all the results that follow "spinal strain."

What, for example, is the explanation of the decreased activity of the efferent nerves from segments of the spine which are so lesioned? Why are the blood pressure, heart beat, etc., not increased by stimulation of the central end of an afferent or mixed nerve after a "spinal strain" has been produced in the upper thoracic region as much as before? Why do not the splanchnics inhibit peristalsis of the intestine from stimulation of a sensory

nerve after lesion in the mid- or lower thoracic as they almost invariably do before such "spinal strain" was effected?

The fatigue of the nerve elements may and probably does have much to do with this, but we believe the disturbance of both the afferent and efferent vascular elements plays a more important part. It is known that the functional activity of the neuron varies directly with the arterial supply and the venous drainage. This is readily understood when we consider the nerve cell as any other cell and that it must have oxygen and other food elements from the blood, that it may be able to function normally. Furthermore, it must have a good drainage, that its carbon dioxide and other products of metabolic waste may be removed. As Sherrington so excellently puts it, "In the first place, nerve cells, like other cells, lead independent lives—they breathe, they assimilate, they dispense their own stores of energy, they repair their own substantial waste; each is, in short, a living unit with its nutrition more or less centered in itself. Here, then, problems of nutrition, regarding each nerve cell and regarding the nervous system as a whole, arise comparable with those presented by all other living cells." This explanation as offered here relative to the blood supply for the decreased activity of nerve tissue was not borrowed from the old stock answer given by most osteopaths when asked how the lesion produces its effect. It is not an answer given from hasty evidence or none, as we often hear the answer "Nature does it." It is not a guess at which we have blindly jumped or a shield behind which we may conceal our supreme ignorance, but a scientific conclusion at which we have arrived after having given careful consideration to the experimental evidence at hand.

Drs. McConnell and Farmer have found that the structures about the joint after such lesions were produced were much congested, and we have found the same to be true. We have found further that it is not possible to obtain normal efferent effects by afferent stimulation until long after the immediate effects of the "spinal strain" have seemingly ceased. We have found that the stimulation of the efferent nerve trunk after stimulation



produces normal functional effects as it did before lesion, therefore the trouble must lie within the cord or other seat of nerve-cell origin. Just here, by way of explanation, we should say that by this the explanation of the decreased functional activity of the spinal autonomies from reflex stimulation after spinal lesion, as has been demonstrated in this and the preceding series (No. 9), depends upon the structural and functional differences between the conducting mechanism in nerve trunks and the reflex arcs of the cord, particularly the synaptic arc.

The conductivity in the reflex arc presents many characteristic differences from that of nerve trunks, as follows: "Slower speed as measured by the latent period between application of stimulus and appearance of end-effect, this difference being greater for weak stimuli than for strong." \* \* \* "Fatigability in contrast with the comparative unfatigability of nerve trunks." \* \* \* "Much greater dependence on blood circulation, oxygen." (Verworn, Winterstein, V. Baeyer, etc.) It is, then, this intercellular connecting mechanism, that which carries the energy from axon to dendrite within the gray matter of the cord and is transmitted to or serves to excite to activity the intracellular energy of the efferent neuron, which is most affected and which offers resistance to the passage of impulses in reflex block. It has been shown (Series Nos. 2, 5, 8, and 9) that this condition, which we may now call reflex block, is maintained as long as the structural perversion (bony lesion) is maintained, and that a return to normal always results from five to sixty minutes after the vertebral perversion has been released. This time allows for the normalization of the blood supply to the synaptic portion of the reflex arc. We are, of course, referring to the immediate effects of experimental bony lesions and not to chronic lesions.

By this explanation we do not mean to exclude all possible effects of direct nerve stimulation by mechanical pressure to the nerve trunk or to sensory endings in or about the joint. We know of no experimental evidence to show that direct nerve stimulation is not a possible explanation of certain phenomena following bony lesions; but this will be discussed in another series in which some work has been done along this line.

## CHAPTER LIX.

### SERIES NO. 12.

# VERTEBRAL LESIONS AND OSTEOPATHIC THERAPY.

J. DEASON, D. O., and A. R. BELL, D. O.

The purpose of this series of experiments was to try the effects of osteopathic lesions on monkeys, and if possible, after functional disturbances had occurred, following the production of bony lesions, to determine the effects of corrective manipulations on these animals. Monkeys were selected for this work because of their closer resemblance, structurally and functionally, to the human species.

**Literature.**—Animal experimentation for the purpose of determining the effects of osteopathic bony lesions on functional disturbances, pathological changes, etc., has now been done on hundreds of animals and by different workers, the published results of which should be common knowledge to every student and graduate of osteopathy. \* \* \*

**Care of Animals.**—Each monkey was kept in a separate cage, an iron frame covered with wire netting, the floor of which was of hardware cloth under which was a zinc pan for the purpose of draining the urine into containers. Each cage was 30x30x20 inches, which gave the animal plenty of room. These cages were cleaned regularly by washing with a hot-water and steam hose. The animals were fed twice daily and the diet kept as regular as possible, which consisted of apples, corn, cabbage, parsnips, toasted bread, etc.

**Normalization.**—Samples of urine were taken daily and analyzed. (The methods described in Series No. 4 were followed.)

The character, consistency, and amount of feces were noted, the appetite was observed, and the weight of each animal recorded. All animals were kept from four to six weeks under observation before they were lesioned. Monkeys Nos. 2, 3, 4, and 10 died from pneumonia within three weeks after they were received, but only one other animal (monkey No. 11) showed any symptom of disease during normalization, and this case will be recounted later.

During normalization all animals either remained constant or gained in weight except No. 11, which lost weight from 2,200 to 1,800 grams. This monkey had tuberculosis when received.

No. 1.—Young Java monkey, increased in weight from 850 to 900 grams.

No. 5.—Rhesus monkey, increased in weight from 1,545 to 1,625 grams.

No. 6.—An old ring-tailed monkey, increased from 1,765 to 1,800 grams.

No. 7.—Ring-tailed monkey, remained almost constant in weight at 1,000 grams.

No. 8.—Rhesus monkey, gained in weight from 2,000 to 2,400 grams.

No. 9.—Ring-tailed monkey, increased in weight from 1,000 to 1,050 grams.

No. 12.—Rhesus monkey, remained almost constant in weight at 2,400 grams.

The fact that these animals remained constant or gained in weight during the period of normalization shows that they had good care and were free from disease up to the time of lesion. There were no symptoms or signs of disease (other than No. 11, given above), except occasional variations in urinary findings, the reasons for which will be stated later.

**Methods of Producing Lesions.**—The animals were placed under deep ether anesthesia and lesions produced by fixing the vertebra at the point desired and rotating the animal's body. In some instances it was only necessary to manipulate the processes of the vertebra between the thumb and fingers to effect rotation, but in most cases we tried to produce lesions which would involve two or more segments at the same time. All lesions produced were rotations. We were always careful in the production of lesions to not cause sufficient trauma to in any way produce a fracture or ligamentous strain, therefore no traumatic effects to the cord were ever produced.

**Results.**—The functional disturbances following lesion in each animal will be given under headings significant of the disorder produced, for the purpose of clearness.

#### NUTRITIONAL DISTURBANCES FOLLOWING LESIONS IN THE UPPER THORACIC REGION:

Monkey No. 5.—Lost in weight from 1,825 to 1,425 grams during four weeks following lesioning. After the lesion was corrected this animal increased in weight to 1,520 grams in two weeks.

Monkey No. 7.—Lost in weight from 1,020 to 900 grams during two weeks. Correction of the lesion was not tried. (See special note on No. 7.)

Monkey No. 8.—Lost in weight from 2,400 to 2,075 grams during four weeks and regained to 2,225 two weeks after lesion was corrected.

Monkey No. 9.—Showed a slight gain for one week and then lost from 1,050 to 925 grams during the three following weeks. Two weeks after correction of lesion this animal gained in weight to 1,000 grams, its normal weight.

Monkey No. 12.—Lost in weight from 2,400 to 2,112 grams during four weeks following lesioning, and regained to 2,150 two weeks after lesion was corrected.

Monkeys Nos. 1, 6, and 7.—Were kept for control; i. e., they were kept unlesioned on the same food supply in the same room, with all environmental conditions the same. During all this time monkey No. 1 showed a constant gain from 900 to 1,000 grams. Nos. 6 and 7 remained constant in weight.

This we believe controls the experiment quite well, and the cause for this loss in weight of the four lesioned animals would seem to be the thoracic lesion. By reference to the above discussion on normalization it will be seen that only normal animals were used and that those which had been showing a constant increase in weight during the period of normalization showed a marked decrease after lesioning. We should not, of course, be so hasty as to conclude that the upper thoracic lesions are always followed by loss in weight, nor would we ever assert positively that the lesions were responsible for the decrease in weight in these cases. Too few animals have been tried and the test has not continued long enough to make positive statements.

#### INTESTINAL DISTURBANCES FOLLOWING THORACIC LESIONS.

Seven monkeys were lesioned, some in the mid- and some in the lower thoracic region. Intestinal disturbances and variations in the urinary findings were noted after these lesions. The results of urinalysis are given later. The intestinal changes only are to be given under this heading.

Monkey No. 1 showed no symptoms at all that we could observe; there was no diarrhea nor constipation at any time.

Monkey No. 5.—The next day after lesioning this animal had a marked diarrhea, which increased for one week, when the lesion was corrected. After correction of the lesion the diarrhea stopped and remained normal for a week, when the lesion was reproduced. This was followed by diarrhea as in the first instance, except that it was more severe. Nine days later the lesion was corrected, and, as before, this treatment was followed by an immediate cessation of the diarrheal condition. This monkey was lesioned a third time, twelve days later, which caused the same symptoms, but this time treatment seemed only to offer a temporary relief. We were never able to stop the condition, which grew constantly worse until the animal was killed, one month later. There was some loss of weight during this time, but we think this was probably due to the extreme diarrheal condition, rather than any interference with systemic metabolism, as the animal's health was otherwise good.

Monkey No. 6.—Showed no intestinal disturbances, but was only kept in lesion a few days. (See special discussion of Monkey No. 6.)

Monkey No. 7.—Showed a slight diarrhea for a few days only. Corrective treatment was not tried. (See discussion on No. 7 elsewhere.)

Monkey No. 8.—Showed a slight diarrhea the following day after lesioning. This continued so for fifteen days, when the lesion was corrected. The diarrhea stopped and stools remained normal for a week, when the animal was re-lesioned. Diarrhea again occurred, which lasted for a week and stopped after a second correction of the lesion. The diarrhea was never severe in this animal, and there was a constant increase in weight during the entire time.

Monkey No. 9.—Showed no diarrhea or constipation after these lesions and the weight remained nearly constant.

Monkey No. 11.—A severe diarrhea developed in this animal after lesioning, and as in No. 5, immediately stopped after the lesion was corrected. This animal was lesioned in both upper and lower thoracic regions, but was not tried a second time. (See discussion No. 11 below.)

No. 12.—After lesioning this animal showed diarrhea almost immediately, which continued for one week and stopped after correction of the lesion. The animal was re-lesioned seven days later, and a diarrhea appeared which, though not so severe as in No. 5, continued for three weeks, when corrective treatment was followed by normal feces. This animal continued to gain in weight during the time of lesion. It was kept unlesioned for one month longer, when it was killed for pathological examination. No diarrhea appeared during this last month and the weight increased in greater proportion than during the period of lesion.

## URINARY FINDINGS.

Samples of urine, free from feces and other contamination, were collected daily when obtainable.

Following is a summarized record of each animal used:

Monkey No. 1.—Seven analyses, covering a period of five weeks, were made. During the time of normalization and on one day only was sugar found. This amounted only to a slight trace and might be explained by the fact that an excess of bananas was given in the diet at this time, which seemed

to produce alimentary glycosuria. The lesion produced was in the mid-dorsal area of the spine. On the second day after the production of the lesion sugar appeared in the urine and continued to show for ten days. The amount present averaged one per cent daily for the entire ten days.

Monkey No. 5.—During the time of normalization this animal showed an average of .2% sugar in its urine. At the same time, the monkey gained 100 grams in weight, which would tend to show that the glycosuria was of the alimentary type, since in pathological glycosuria loss of weight invari-

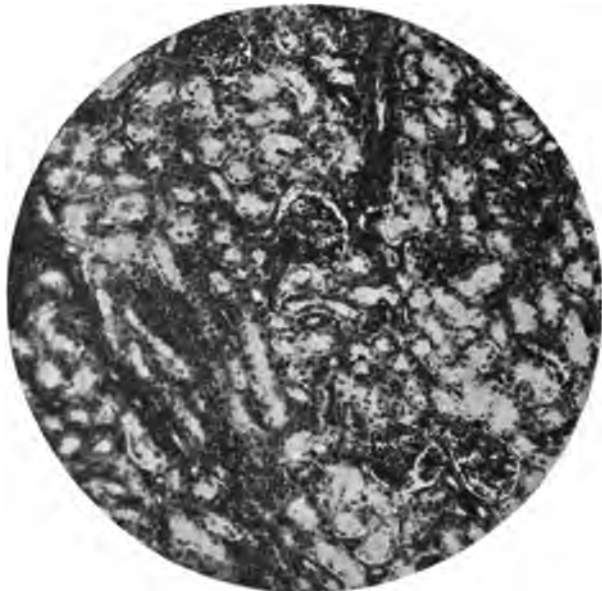

FIG. 72.—Section of kidney showing albuminous degeneration. Taken from monkey lesioned in lower thoracic region. X 120 diameters. (Reduced 20%.)

ably occurs. A mid-dorsal lesion was produced and in the eight days following the average daily elimination of sugar was .50%. After correction of lesion this animal showed an average of .2% of sugar for two consecutive days, and for the following six days the urine was absolutely free from sugar. During period of lesion this animal lost constantly in weight.

Monkey No. 8.—During time of normalization seventeen analyses were made. For seven days of this time the daily average was .24% of sugar. (It was during these days that the banana diet was used.) During the remainder of the normalization period the urine was free from sugar, giving a daily average of .1% for the entire time. After the production of a mid-dorsal lesion the urine showed a daily average of .4% of sugar for the following ten days.

After reduction of the lesion analyses were made for the following five days. These showed slight traces of sugar for the first two days and sugar-free urine for the remaining time.

Monkey No. 9.—During the normalization period nine analyses were made. The daily sugar average was .08%. This animal was kept in lesion one week and during that time showed a daily average sugar elimination of .30%. After reduction of the lesion, sugar-free urine was voided.

Monkey No. 11.—This animal was normalized for a period of four weeks. Seven analyses were made during this time and only once was sugar found. This gave a total daily average of .05%. For the following ten days, after the production of a mid-dorsal lesion, this animal showed sugar every day except two, giving a daily average of .36%. Correction of lesion in this animal was not effected.

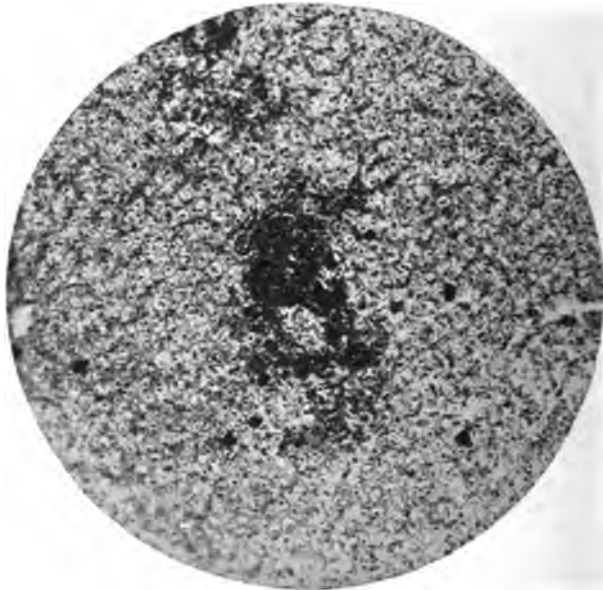

FIG. 73.—Section of liver taken from monkey lesioned in mid-thoracic, showing small abscess and albuminous degeneration. X 120 diameters. (Reduced 20%).

Monkey No. 12.—Normalization record was kept on this animal for one month, during which time eight analyses were made. These showed a daily average of .14% sugar. A mid-dorsal lesion was produced. The urine on the following day showed sugar and continued to do so for eight days. The average amount during this period was .48% daily. Eleven analyses were made after correction, which showed a daily average of .06%.

The presence of sugar in the urine during the period of normalization was in all probability due to an excess of bananas being given in the diet, as the sugar appeared in all the animals' urine at a time when simultaneously bananas were being heavily

fed. After taking the bananas from the diet and using grain and acid fruits instead, the sugar elimination ceased. This same diet of grain, apples, etc., was used during the times of lesion and following correction and was kept constant, no variations being made in it.

**Summary.**—All animals used showed a much increased amount of sugar elimination during time of lesion, which was

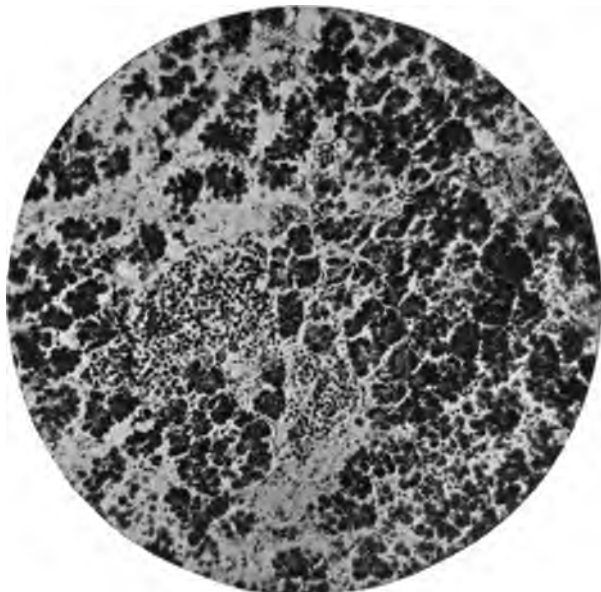

FIG. 74.—Section of pancreas from monkey lesioned in mid- and lower thoracic regions. Islands of Langerhans show fibrosis. X 120 diameters. (Reduced 20%.)

either greatly reduced or entirely eliminated when the bony subluxation was corrected. We believe the sugar elimination to have been pathological, as the animals constantly lost weight during the same time.

The presence of such amounts of sugar as appeared during the time the animals were in lesion definitely shows this: That in some manner bony subluxations produced in the mid-dorsal



region of the spine deranged body metabolism, and caused functional disturbances of the nutritional processes.

#### OTHER FUNCTIONAL DISTURBANCES FOLLOWING LESION.

Monkey No. 7.—This animal was kept under observation for fifty-eight days before lesioning. During this period the animal was in perfect health and increased some in weight. After lesion in the upper and mid-thoracic region the animal lost in weight from 1,020 to 900 grams in two weeks. It then contracted pneumonia and died in three days after the first symptoms appeared. On post-mortem the lungs were found badly congested.

Monkey No. 11.—This was a female Rhesus monkey seemingly in good health, except that it coughed occasionally. Bacteriological examination of throat smears failed to show any specific infection. After lesion in upper dorsal there was an extreme diarrhea, and the cough grew worse. The diarrhea stopped after corrective treatment applied to the lower thoracic region, but the cough and other symptoms increased. The animal was now losing weight very fast. It seemed to be hungry and ate well, but gradually grew weaker and became very inactive. Extreme swelling of the face region and much cyanosis had developed one week later, when it died. Post-mortem examination showed a general systemic acute miliary tuberculosis. Practically every visceral structure was involved. In this case we are quite sure that the animal had tuberculosis when it was received, but certainly in these two animals there is much reason to believe that the lesions acted as in the one case (No. 7) predisposing, and in the second case (No. 11) an exciting factor to the infective processes.

Monkey No. 6.—This was an old ring-tail, but was in good physical condition when received and remained so for two weeks. The appetite was good and the urine and feces were normal. At this time it received a severe fall. Its keeper accidentally threw it hard against the floor when it tried to bite him. The animal gave evidence of an injured neck; after four days it was not so lively and seemed ill; ten days later there was trouble with its right arm; it would put the left arm only out for food and did not use both hands ambidexterously as formerly, and as all monkeys do while eating. A few days later the right leg was involved. This gradually progressed until the right arm was completely spastic. The left limbs were also involved and the left arm showed signs comparable to intentional tremor when it reached for food. It was very irritable during the entire time. After death, on post-mortem examination, the atlas and axis were both found to be slightly anterior and rotated to the right. There were no other bony lesions, nor was there any evidence of trauma to the cord. We think the symptoms could not be explained by the theory of "spinal shock." Probably the term "spinal strain" of an extreme type, some of the effects of which have been given in a previous series, would explain the causes in this case.

**REPORT ON PATHOLOGY.**

T. L. McBEATH, D. O.

The animals were killed by administering ether, and were posted by Dr. Deason and myself.

**Pancreas.**—Shows infiltration of fibrous tissue running in between the glandular structure. The islands of Langerhans show fibrosis (fibrous tissue surrounding and infiltrating into the glandular structure of the islands).

**Kidneys.**—Show slight albuminous degeneration in the first convoluted tubules in cortical area, the renal epithelium is frayed into the lumen, and the cytoplasm appears granular.

**Liver.**—Outline of cell membrane intact, the cytoplasm slightly granular in intermediate portion of lobules; also small abscess near hepatic artery, showing accumulation of polymorphonuclear leucocytes in surrounding tissue, causing slight necrosis of tissue.

## CHAPTER LX.

### SERIES NO. 15.

# CONTROL WORK ON MAMMALIAN SERIES NOS. 2 AND 7.

H. L. COLLINS AND CHAS. R. EITEL.

Since the result of Series No. 7 done by us last year dovetail so nicely with the work done by Doctors Deason and Robb in Series No. 2, the result of one series strongly supporting the other, it seemed advisable to continue the work on this series. As our work along this line was simply to act as a control on mammalian Series Nos. 2 and 7, it would not be necessary to give any lengthy detailed account here, but just a few statements of our findings, which will be self-explanatory.

Seven dogs were used in this series. The methods and precautions are the same as those used in Series No. 7.

In almost every instance pressure, flexion, or manipulation in the lower cervical and upper dorsal regions, with a fixed point gave an increase in blood pressure. The fact was also confirmed that when flexion was applied to the vertebræ with no fixed point, there was not nearly as much variation produced as when a fixed point was established. In the few exceptions to these results there was a vertebral lesion found in some of the dogs which might have produced these contrary findings, but as there were so few of these negative results obtained and so many in the affirmative, we are forced to believe that manipulation, pressure, or flexion in the lower cervical and upper dorsal produces an increase in blood pressure, and the same movements, viz., pressure, manipulation, or flexion in the lower dorsal and lumbar produces a decrease in blood pressure.

One interesting thing might be restated from the work done by Doctors Deason and Robb: When two different kinds of stimulation were used in one region they confirmed our results of Series No. 7. We will mention one instance here. When rotation and pressure were both applied to the upper lumbar a decrease in blood pressure in both instances was recorded. This not only helps to prove the statement of Series No. 2, but also upholds our findings, which are stated in Series No. 7.

### CONCLUSIONS.

In summing up this problem we find:

1. Vertebral movements, when applied to different areas of the spine, produce radically different effects, as has been stated in Series No. 2.

2. That flexion of the spine, with a local fixation, gives more marked results than flexion without fixation.

3. That the effects of muscular massage are inconsiderable as compared with spinal movement with fixation.

4. The results of Series Nos. 16 and 17 confirm our findings and the results of Series No. 2, that manipulation of different areas of the spine produces not only different, but more or less specific, physiological results.

These findings are confirmatory of Series No. 2, published in the April number of the Journal of Osteopathy, 1911, under heading "Some Physiological Effects of Vertebral Movements Experimentally Produced," and of Series No. 7, published in the July, 1912, Journal of the American Osteopathic Association.

## CHAPTER LXI.

### SERIES NO. 16.

# EFFECTS OF SPONDYLOTHERAPIC AND OSTEOPATHIC STIMULATION ON THE SECRETION OF URINE.

C. A. PENGRA AND G. A. ALEXANDER.

It was the purpose of this series of experiments to determine as far as possible the effects upon the secretion of urine by the kidneys when stimulated by the application of spondylotherapeutic concussion and of osteopathic manipulation in the region of the spine, from which the nerve supply of the kidney is derived.

It was not the purpose to determine the correctness of, nor to corroborate nor disprove, any theory that has been advanced regarding the secretion by the kidneys, whether it be the original theory of Ludwig that "urine is formed by the simple physical process of filtration and diffusion," or the later theory of Bowman and Heidenhain, which assumes that "water and inorganic salts are produced in the glomeruli, while urea and related bodies are eliminated through the activity of the epithelial cells in the convoluted tubules." (Howell.)

The animals used were dogs, eleven in number, to ten of which ether was administered deeply and constantly by means of the tracheal cannula.

The animals were not operated after anesthetization until such time as respiration became rhythmical and pulsation strong and regular, when an abdominal incision was made in the median line and both ureters cannulated, the cannulae being long and extending out into graduated test tubes. Again, time was allowed for the rate of flow to become normal, i. e., to regulate itself after any possible shock of the operation to an even and regular flow.

Several counts were then taken about ten minutes apart to ascertain the exact rate of normal flow, after which stimulation was applied by concussion and manipulation to the regions indicated, sufficient time being allowed each time for the effects to be demonstrated and for normalization to occur. It will be observed that the increase in flow after osteopathic manipulation was applied invariably remained constant until the animal was killed, which was not brought about for a period, in many cases, of from one to two hours.

The very noticeable variations in normal flow between the different animals experimented upon were due principally to variations in size, strength, and age, as of course uniformity in these qualities is impossible, although the strongest dogs obtainable were used in each instance and none but normal animals were operated upon.

In the application of stimulation by means of spondylotherapeutic concussion, as suggested by Dr. Albert Abrams in his book (second edition) on treatment, the concussion was applied by the use of a light hammer and a rubber cork, as a percussion pad, always lightly at first and gradually increased to heavy; but, as will be noted in the experiments listed, our best efforts failed to produce the desired results by this method and, in fact, not the slightest change in rate of flow was noted.

The osteopathic manipulation was applied altogether by lateral rotation, making fixed points of the spines of two adjacent vertebræ. In order to know that the effects were being produced directly by stimulation of some nerve mechanism to the organ and not by increase in general blood pressure, or by any change in rate or amplitude of heart beat, or of respiration, the mercury manometer was attached to the carotid and the pneumograph to the trachea of the animal, but these instruments failed to record any variations which would be indicative of the changes sought in respiration or in general blood pressure.

Following is a list of two of the dogs operated, the remaining nine not being listed for lack of space, but showing similar results:

Dog No. 1.—Operated 2:45 p. m.; normalized 3:20 p. m.

Four counts taken to ascertain the normal rate of flow showed the left ureter to be eleven drops per five minutes and the right to be ten drops per five minutes.

At 3:45 p. m. percussion was applied; as stated above, without effect.

At 4:00 p. m. osteopathic manipulations were applied, resulting in an increase of two drops per each ureter per five minutes or an increase of 20 per cent.

A second count taken at 4:25 p. m. showed a second increase of one drop per ureter per five minutes.

At 4:40 p. m. the same manipulation applied to the same region resulted in increasing the flow of the right ureter to sixteen drops and the left to eighteen drops per five minutes, or more than 20 per cent.

At 5:00 p. m. the flow remained the same, and the dog was killed.

Dog No. 11.—This animal was operated upon under aseptic conditions, ether being administered by means of a cone, after which it was thoroughly bandaged, the cannula passing to the outside through a slit in the gauze. It was then swung in an improvised hammock in a sterile cage, in such a manner that it could cause no injury to itself.

Two hours after the dog had recovered from the effects of the anesthetic, counts were taken to ascertain the normal flow of urine, which was eleven drops per ureter for fifteen minutes. Osteopathic manipulation applied to the region of the twelfth and thirteenth dorsal increased the flow immediately to 18 drops per ureter per fifteen minutes. Another count thirty minutes later showed that the flow had again increased to 26 drops per ureter per fifteen minutes, a total increase of 136 per cent.

The animal was then taken from the hammock and allowed to rest in the cage over night. At 9:00 a. m. the following day the animal's temperature was 37° C. (normal), but it seemed very thirsty; was given milk.

A count was taken to ascertain the normal flow, which showed it to have remained almost constant during the night, being twenty-four drops per ureter per fifteen minutes.

Because the animal seemed thirsty and the count still remained high, it would seem that the total amount of elimination had been much increased during the period.

The same manipulations were applied as on the previous day, resulting in an increase to 36 drops per ureter per fifteen minutes. A second count was taken one hour later, showing that this increase had remained constant.

This animal was examined thoroughly at 3:00 p. m. the same day and found to be in perfect condition, the temperature being normal and showing no signs of infection from the operation.

### SUMMARY AND CONCLUSION.

J. DEASON, M. S., D. O.

The above series of experiments was done under my supervision and I believe every possible precaution was observed to eliminate errors.

The care and operative technic of these workers was excellent. No animal suffered from shock due to unnecessary expos-

ure. The greatest care was exercised in the handling of the animals to avoid any undue mechanical stimulation, etc., and the results obtained could not possibly have been due to anything other than spinal manipulation. Further evidence of this was shown in Dog No. 11, which showed even a greater increase in urine secretion from spinal treatment than the animals while under the influence of ether. The increase, therefore, can not be attributed to the effects of the anesthetic or any careless handling while being operated.

It may be suggested that the results came from massage of the spinal musculature, but that this is not at all probable we cite the reader to Series Nos. 2 and 15 of our mammalian experiments, which show that massage is neither so effective nor specific as osteopathic treatment. Those who wish to explain these effects by massage will first have to answer this question, viz., why is this excessive activity caused only by a specific kind of spinal treatment applied to a specific area, while other methods utterly fail?

From the results of this work we may draw the following conclusions: 1. That spinal concussion, when thoroughly tested, produces absolutely no effect upon the functional activity of the kidneys; 2. That by proper osteopathic manipulations the functional activity (secretion) of the kidneys can be increased from 20 per cent. to 100 per cent., or even more; 3. That this increased activity lasts for a sufficient length of time to very materially reduce the body water content; 4. That there is a certain definite region of the spine (eleventh and twelfth dorsal) from which the autonomies originate, which controls the functions of the kidneys; 5. Since there are no changes in systemic blood pressure, this increased function of the kidneys is due either to specific vasomotor or secretory (trophic) nerve fibers, which may be influenced without causing general systemic vasomotor changes; 6. That spinal treatment may be given in such a way as to be specific in effect, i. e., to effect only certain functions.

**Osteopathic Significance.**—It has been shown, Series Nos. 4 and 12, that bony lesions of the lower thoracic and upper



lumbar regions produced artificially in normal animals affect the normal functions of the kidneys. Clinically, many cases of kidney trouble have been demonstrated to be due to similar lesions.

In this series it has been shown conclusively that the secretions of the kidneys can be increased from 12 per cent. to 100 per cent. by stimulatory treatment applied to the eleventh and twelfth thoracic segments of the spine. The secretion thus produced often remains increased for two or three hours or longer, during which time the water content of the body is greatly reduced.

This same experiment has been tried with equal success on the human, and by this means in cases of febrile conditions the toxins of the body fluids and the temperature have been much reduced in a number of cases in which the test has been applied.

The practical significance of such treatment is therefore apparent. If the toxin content of the blood can be materially reduced, as this experimental evidence shows it can be, this is a very efficient method of treatment in infectious fevers. Spinal manipulation, which produces free movement between the vertebræ named, should be continued for ten or fifteen minutes at each treatment and several such treatments given daily during the febrile state.

Dr. McConnell has shown that bony lesions of the mid-dorsal and lower dorsal regions are followed by pathological lesions of the kidney, and Dr. Burns has shown that lesions of the eleventh and twelfth thoracic produce vaso-dilation of the vessels of the kidneys.

## CHAPTER LXII.

### SERIES NO. 17.

# OSTEOPATHIC STIMULATION OF BILE-FLOW.

GEO. D. SCOTT AND H. A. WENDORFF.

This is the record of a series of experiments undertaken at the instance of Dr. J. Deason in the laboratories of the American School of Osteopathy to ascertain whether or not the physician can in any way influence the flow of bile. As will be seen, the results were most gratifying. Carefully tabulated records were kept of the findings, but as the whole series of tables would occupy an undue amount of space, it is deemed best to give only the results obtained in each case, and to group them all in one table.

**Methods and Technique.**—Dogs were the only animals used; the technique was extremely difficult and tedious, but great care was taken to assure that the results obtained were exactly accurate in each case.

All dogs were put under complete anesthesia by means of ether given by tracheal cannulæ. The animal was tied onto a table of small size kept for the purpose, and an incision made in the abdomen, extending from the xiphoid toward the symphysis. The operator then passed his hand into the abdominal cavity, grasped the common bile duct and pancreatic duct and other structures thereto attached, and after closing off the bile duct by means of a "bulldog," it was cannulated at a point above its junction with the pancreatic duct.

Many peculiarities of structure were found in different animals, and the operators were obliged to lose many dogs without even getting the duct cannulated. One animal had a bilateral liver, and the common bile duct was divided up into so many

smaller ducts that nothing could be done. This is only one illustration of the difficulties met with. In fact, a lengthy article could be written on the abnormalities of structure found in many of the animals opened.

After cannulating the duct and inspecting the gall-bladder to see that it was normal and to ascertain the approximate content, the "bulldog" was removed, the edges of the skin brought together and fastened, the right limbs untied from the table, and the animal turned onto the left side.

Stimulation was effected by rotation of the seventh to ninth dorsal vertebræ, but mostly the eighth, as follows: The operator stood at the animal's back and, in order that there might be no compression on the abdominal cavity, thus influencing the flow of bile, grasped the dog's right foreleg in the left hand and with the right rotated the vertebræ by means of the spinous processes. At the close of each experiment the gall bladder was again examined and in every case found to contain as much bile as at the beginning with one or two exceptions, when a perceptible increase was present.

	Normal flow in 15 min. drops.	Flow in 15 min. stim. mid- dorsal.		Flow after stim. ended drops 15 min.
Dog No. 1.....	55	72	30.9% inc.	68
Dog No. 2.....	41	78	90.2% inc.	74
Dog No. 3.....	46	69	50 % inc.	65
Dog No. 4.....	57	76	31.5% inc.	67
Dog No. 5.....	52	74	42.3% inc.	69
Dog No. 6.....	45	81	80 % inc.	75
Average.....	49	75	53 % inc.	69.6

As will be seen from the above table, the normal rate of flow was taken before stimulation was started and again after stimulation ceased, and the increase in flow from the manipulation continued for some time afterward, though not at the same rate. In one or two cases by count, the increase was noted for as long as half an hour, it gradually receding toward the normal.

Some animals, other than those from which results are tabulated above, were prepared in the usual way and "spondylotherapy" attempted by percussing the spines of the vertebræ

in the same region as stated above, but in not a single instance was there an increase in the bile-flow, and the experiments were abandoned. Five dogs were used in this way. The carotid artery and trachea were attached to the kymograph, but not the least variation in either blood pressure or respiration occurred during the percussion.

## CHAPTER LXIII.

### **PERVERTED PHYSIOLOGICAL EFFECTS AS A RESULT OF OSTEOPATHIC LESIONS.**

From the evidence which has been offered in the foregoing pages in the second part of this book, it may be seen that we have arrived at no hasty conclusion in stating quite positively that we know that those structural perversions which have so long been recognized and known as osteopathic lesions are productive of functional perversions, which are detrimental to the well-being of the animal. Instead of hastily concluding, we have on the other hand progressed slowly, step by step, and have offered undeniable experimental evidence of the relations of these structural perversions to the abnormal physiological and pathological conditions of which they are known to be the cause.

The clinical side of the evidence is of course not to be found in this book, but ample osteopathic literature may be had dealing with this phase of the subject, and this, the clinical evidence, has done far more in the past to turn people towards osteopathy as a method of healing than has the experimental evidence. Realizing this fact, as we do, and after having had a few years of experience in the application of these principles to many different clinical conditions (mostly the acute infectious fevers) and after having worked several years at original experimental research, we believe we have a right to express an opinion and that opinion is that osteopathic methods of therapy are scientifically sound, both theoretically and practically.

It is no longer a question as to whether the bony lesion is causative of perverted physiological and pathological effects, for this has many times been demonstrated by the finding of bony lesions so constantly in association with the clinical conditions,

and the fact that many different experimenters have conclusively shown that the production of "artificial bony lesions" in normal animals is followed by clinical conditions and demonstrable pathological changes comparable to those conditions found in human individuals. It is not any longer a question as to whether the correction of these bony lesions is conducive to the normalization of the perverted physiological conditions, for this has been answered in the affirmative by the results of the most excellent work of those earnest physicians whose trained brains and hands have done the correcting of such lesions in human individuals and by the results of original experimentation, which has shown that the correction of the "artificial bony lesion" in animals will be followed by a relief of the symptoms which their existence had produced.

The question now for osteopathic physicians is: "What is the method by means of which the bony lesion causes these disturbances?" This once answered, we may be better able to reason from cause to effect and apply our treatment accordingly. In the following pages of this chapter we will briefly discuss the different theories which have been offered for the explanation of the mechanism by means of which these effects are produced.

**Direct Pressure on Nerve Trunks.**—This theory maintained that the effects from bony lesions occurred as the heading suggests, from direct pressure upon the nerve trunks by immediate impingement. Such explanations seem improbable, because from a knowledge of the anatomical relations of the vertebral segments, such a direct impingement of the nerve trunks would seem improbable, at least, if not impossible. There are some conditions in which direct pressure effects might account for these results, such for example as in case of lesion of the sacro-iliac synchondroses and probably in some other instances, direct pressure effects may account for the physiological perversion by direct traumatism, either by pressure or stretching effected upon the nerve trunk. In such cases the effects at first would probably be a stimulation to the structure supplied by the efferent fibers in the nerve trunk and reflex effects causing increased activity

of the centers in the cord lying in immediate or near relation with the afferent fibers which enter the cord from these nerve trunks. By this means it would be possible to explain many so-called reflex effects which are known to result from bony lesions.

By far the greater part of the better osteopathic authorities is not and has never been in favor of such an explanation of the effects of bony lesions. We do not know of any case where the results of original osteopathic research would bear out the ideas of this theory except in a few rare instances, as explained above. In cases where artificial lesions have been produced in animals for the study of the results the dissection of the structures after the lesion had been produced has, so far as we are able to determine, never shown that there was any direct impingement upon the nerve trunks.

**Reflex Effects.**—This theory has been advanced, the principle of which is that excessive stimulation of the afferent fibers caused by a strain in or about the joint segments involved in the lesion, which in turn causes reflexly a greater amount of stimulation in the synaptic part of the cord and, therefore, a greater amount of efferent stimulation by way of the nerve fibers (somatic and splanchnic efferents) extending from cell bodies in the anterior and antero-lateral part of the gray matter of the spinal cord.

As evidence of this explanation we offer the following: 1. It has been shown experimentally by Dr. McConnell that osteopathic lesions produced in normal animals cause pathological changes in the afferent fibers of the spinal nerves and in the afferent columns of the cord. Such conditions would of course influence the normal reflexes and on long standing impair the functions of structures supplied by efferent fibers from the involved segments by reducing their tone, trophism, vasomotor supply, etc.; 2. It has also been shown experimentally by Dr. Burns that lesions produced in normal animals and in the human cause immediate reflex effects characterized by marked perverted physiological functions such as excessive secretion, abnormal vasomotor control, etc.; (See Dr. Burns' chapter on reflexes.) 3. In our research work it has been shown that bony lesions produced

in normal animals cause many reflex effects, e. g., abnormal movements of the stomach and intestines (see Series 5 and 9), abnormal functions of the heart and blood vessels, and other perverted conditions (see Series 10).

The results of observations of many physicians in their clinical practice also bear out the statement that osteopathic lesions produce a great variety of symptoms which may usually be relieved by the correction of the structural perversion. In order that the effects of the osteopathic lesion on the reflexes may be better understood the relation of the lesion to the synaptic nervous system should be carefully considered, since this system is involved in all reflex actions.

**Involvement of the Synaptic Nervous System.**—The reader is urged to review the physiology of this system, that he may be better able to understand the principles involved. (See text, page 272, Part I, and Series No. 10, Part II.) The term synaptic nervous system has been applied to those intermediate fibers which lie principally in the gray matter of the cord and brain and which constitute the connection between the afferent and efferent neurones and complete the reflex arc. The term "synapse" is applied to the connections which exist between the afferent and efferent fibers. (See page 272.) To understand the physiology of this connecting mechanism we must consider that these interconnecting neurones, the commissural and association neurones, constitute actual living cells and, as we have quoted from Sherrington before, "nerve cells, like all other cells, lead individual lives—they breathe, they assimilate, they disperse their own stores of energy, they repair their own substantial waste; each is, in short, a living unit, with its nutrition more or less centered in itself. Here, then, problems of nutrition, regarding each nerve-cell and regarding the nervous system as a whole, arise comparable with those presented by all other living cells. Although no doubt partly special to this specially differentiated form of cell life, these problems are in general accessible to the same methods as apply to the study of nutrition in other cells and tissues and in the body as a whole."



We see, therefore, in this mechanism a highly differentiated structure whose functions are accurately adjusted for the performance of a highly specialized function. "At each synapse a small quantity of energy, freed in transmission, acts as a releasing force to a fresh store of energy not along a homogeneous train of conducting material as in a nerve-fiber pure and simple, but across a barrier which, whether lower or higher, is always to some extent a barrier." (Sherrington.) The synaptic part of the reflex arc is actually the functional key to the entire reflex system, and any failure in its function certainly means far reaching perversions of function.

That the osteopathic lesions produced in normal animals affect the functions of the synaptic system has been shown in Series 9 and 10. That these effects are not due to spinal shock we cite the reader to the evidence offered in Series 10. After the production of the lesion in normal animals the reflexes are diminished and the tone of the structures supplied by efferent fibers from the affected segments is reduced. In several of our different series of experimental work we have successively noted that the lesion produced artificially in normal animals is followed by reflex disturbances somewhat comparable to reflex inhibition, but differing from physiological reflex inhibition in that the effects are much more marked and are of greater duration. Since there is evidence that the synaptic nervous system is involved as a result of the osteopathic lesion an explanation of the probable causes of such effects seems to be in order, which we believe is answered in the following paragraphs.

#### **Congestion of the Segments of the Spinal Cord.—**

Several research workers have found that congestion of the spinal cord occurs following artificial bony lesions, which may affect only a few or several segments of the cord, according to the nature of the lesion produced. We have confirmed these findings in our experimental work and believe the greatest amount of congestion occurs in animals in most cases very soon (five to twenty minutes) after the production of the lesion. (It would seem that the same condition ought to be present in the human following

acute bony lesion from any cause.) In some cases this congestion clears away and the opposite, an anemic condition, results, while in other instances the congestion persists.

During the period of congestion we have found that the resistance in the synaptic system is greatly increased. If, for example, as shown in Series No. 10, the central end of some afferent or mixed nerve be stimulated reflex effects, e. g., increased heart rate, increased respiration, etc., result. Now, if an artificial bony lesion be produced in the mid-dorsal region and the experiment repeated, it will be found that the stimulation of afferent or mixed nerves which enter the cord below the point of lesion is not followed by an increase in these functions, while on the other hand stimulation of afferent or mixed nerves which enter the cord above the point of lesion do produce an increase in these functions just the same as the stimulation of all nerves before the lesion was produced. If the lesion be produced in such a way as to involve all of the segments of the cord from which efferent fibers arise supplying a certain structure, this structure is not normally affected reflexly by the stimulation of any sensory fibers, whether they enter the cord above, at, or below the area from which the structure is supplied. This evidence would seem to show that the congestion surely increases the resistance of the synaptic nervous system or builds a "barrier" preventing the transmission of the impulses from the afferent to the efferent conductor. As further evidence of this fact we have found that this marked increased resistance is of comparatively short duration, for from ten to twenty minutes after the production of the lesion the reflex functions begin to return to normal unless the lesion is a permanent one, in which case the return to normal is markedly delayed. This return of the normal reflex functions would seem to be due to the relief of the congested condition of the segments of the cord involved, and a careful examination has tended to confirm this view.

"The living cell is constantly liberating energy in its function, and rebuilding its complex structure from nutrient material. Its life is therefore an equilibrium of balanced katabolism and

anabolism; at any given moment the one process or the other may predominate in the cell." (Sherrington.) Since this is known to be true and since the "nerve cells like other cells lead individual lives," etc., and since these cells demand their normal quota of normal blood, any condition varying this function must certainly affect the functions of these cells. Now because the synaptic system of neurones is necessarily so easily influenced, it follows that this system would be one of the first to be affected by such lesions. We believe, as Dr. A. B. Clark states, that "Dr. Still never spoke the truth more perfectly than when he said 'The rule of the artery is supreme'," because it is the blood supply to the nerve cells which furnishes the energy for the normal functional activity of nerve cells, just the same as normal nutrition is demanded for the function of all other cells. (See Source of Nerve Energy, pp. 305 and 280.)

The excess of blood to the part is not the only and, we believe, not the chief cause of the lack of normal function of the nerve cells in the cord. It has been pointed out elsewhere that the venous drainage from the cord must be normal in order that the cord functions may be normal, as the retention of end products of metabolism, such as  $\text{CO}_2$ , etc., must be promptly removed that the functions of the nerve cells in the cord may be normally maintained. This factor, the retarded drainage of the blood from the cord, is, we believe, the factor which has most to do with the production of the lasting effects of osteopathic lesions. Anything, then, which interferes with the drainage of the blood or lymph from the cord must surely influence these functions. Dr. McConnell has repeatedly shown that reflexly the drainage from the cord and surrounding tissues is affected by artificial bony lesions. It is probable that the blood supply to the cord is influenced reflexly through the vasomotors as a result of bony lesions. The results of experimental work bear out this statement.

It does not seem probable that direct pressure on the arteries supplying the cord is a very probable explanation for these causes, for reasons previously stated. It may be that pressure causing

by congestion a proliferation of adjacent tissue does to some extent interfere with the drainage through the thin-walled veins and lymphatics, but it also seems probable that a loss of tone to the arteries causing excessive dilatation of these structures caused by the effects of the lesion would cause an excess of blood to the part; more, in fact, than could be drained away, and thus a more permanent congestion would follow than would be caused by the reflex effects alone.

**By Affecting the General Integrity of the Central and Autonomic Nervous Systems.**—It has been stated in Part I that there are two general ways (the integrative function of the nervous system and the circulation of internal secretions) in which the unification of all body functions is maintained, and it has been shown how the interrelations of the different parts of the nervous system and the formation, circulation, and activity of the internal secretions bring about this co-ordination of the various body functions. That all of the different structures of the body bear certain functional relations and that these relations are activated and maintained by these two functional systems is now well understood. It is equally well known that unless this functional relationship is maintained that the animal body as a whole cannot perform its normal function, and that a condition of uniform body health cannot exist. We believe that it is a common error of physiologists and physicians to overlook this most important physiological fact.

It has been shown many times and by different research workers that the osteopathic lesion when produced artificially in normal animals affects many and varied changes reflexly, which alter the functions of different structures. It has been shown how osteopathic lesions may interfere with the synaptic system and in fact may involve the entire reflex mechanism, thus preventing the integrative function of the nervous system from co-ordinating the functions of the various structures. To show the interrelation existing between these two systems we quote the following: "This synaptic system co-existing with the diffuse in various places dominates the latter. Thus it controls

and oversees the actions of the local nervous system of the viscera, and heart, and blood-vessels, which even in the highest animal forms remain diffuse.

“The synaptic nervous system has developed as its distinctive feature a central organ, a so-called central nervous system; it is through this that it brings into rapport one with another widely distant organs of the body, including the various portions of the diffuse nervous system itself.” (Sherrington.)

Such perverted functions as (1) impaired regulation of the vasomotor system; (2) impaired secretion of different glands, in some cases the secretion is increased and in other instances diminished; (3) perverted metabolism; (4) decreased function of certain organs of internal secretion; (5) decreased trophic functions, and many others have been observed both experimentally and clinically from the effects of osteopathic lesions.

The lesion, then, by its interference with the normal functions of the nervous system may cause in the different ways explained above many perverted physiological conditions which reduce the normal body resistance and interfere with the normal unity of function of the different organs, which is so essential to health. In considering this function of the nervous system as a regulator of the various body functions Sherrington most interestingly observes that “An actual living internal bond is developed. When the animal body reaches some degree of multicellular complexity, special cells assume the express office of connecting together other cells. \* \* \* And we find this living bond the one employed where, as said above, speed and nicety of time adjustment are required, as in animal movements, and also where nicety of spatial adjustment is essential, as also in animal movements. It is in view of this interconnecting function of the nervous system that that field of study of nervous reactions which was called at the outset the third or integrative, assumes its due importance. The due activity of the interconnection resolves itself into the co-ordination of the parts of the animal mechanism by reflex action.”

The effects of the bony lesion upon this integrative function of the nervous system is a most important physiological and clinical problem. We believe this theory serves to explain the cause of a great many clinical conditions classed by medical physicians as idiopathic because they have no means of determining the cause.

It seems equally probable that many osteopathic physicians may make the same error because an osteopathic lesion sufficient to cause effects of this kind may be only very slight and difficult of detection. Osteopathic lesions in this way may produce their effects slowly, the results being a gradual decrease in the normal resistance of the individual until some secondary cause like bacterial infection hastens the process. Thus we have the so-called predispositions of certain individuals to the various infectious and other disease conditions.

**By Causing Hyperirritation of the Nervous System.—**

That osteopathic lesions are frequently causative factors of conditions of hyperirritability has been observed by clinicians and research workers. Animals after lesioning often become very noticeably nervous and many, if not all osteopathic practitioners have observed that bony lesions may be the cause of nervousness which can usually be relieved by the correction of the lesion. The effects in such cases may be due to an excessive stimulation of the afferent system and the spasmodic nature of the condition may be due to a "summation of stimuli" and an increased resistance of the synaptic system which now and then gives rise to a flood of afferent stimuli passing to the efferent system, which may be the cause of such effects.

The effects of lesions causing such irritability are varied. The effects may involve the entire system, causing general nervousness; it may affect some one structure or group of structures, increasing or inhibiting their functions, or it may only influence the general integrity of the entire system.

**Conclusion.**—In the various ways, as stated in the preceding pages, and possibly in other ways osteopathic lesions have been shown to produce physiological perversions. We have

considered for the most part the different ways by means of which the osteopathic lesion may produce immediate effects. These conditions if long continued would result in permanent effects. As evidence of this fact we refer the reader to the work of Dr. McConnell, who has many times shown that pathological changes result from permanent bony lesions. We have confirmed these results and have further shown that lesioned animals when kept for long periods of time show constantly increasing physiological abnormalities.

## CHAPTER LXIV.

### INNOMINATE LESIONS.

By F. P. MILLARD, D. O., Toronto, Canada.

Clinically speaking, innominate lesions have been known to exist, and have been therapeutically corrected since osteopathy's innovation. The position of the innominate bones is such that lesions, however slight, are significant and have naturally attracted the attention of our physicians from the earliest osteopathic days. Until recently a great many clinical experiments have remained unverified from the fact that our research work has been limited. However, it is pleasing to know that some of our best doctors have been delving into this particular lesion proposition from a research standpoint, and although the reports have not been given out, I am in a position to know that some splendid work has already been done by our worthy research workers, Drs. Deason and McConnell.

We cannot be too accurate. We have always appealed to the people from a scientific standpoint. We have constantly made statements that the workings of the human anatomy were to be referred to on a mechanical basis. Clinical experiments have apparently demonstrated a great many wonderful features. We have longed to verify these reports with accurate and absolute proofs. In a general way I am going to refer to some of the experiments which have been made and which are to be continued at an early date. The innominate lesion is vital in relation to the physiological functionings of the human anatomy. Lesions of this nature are not necessarily direct in their workings, but are in a great part, at least, reflex through the various nerve connections which exist in this section of the anatomy.



Referring to the work that Dr. Deason has been conducting and the various specimens forwarded to Chicago and passed upon by Dr. McConnell, we have this to say: The pathology, while slight, was definite. The medullary sheaths showed a beginning of parenchymatous degeneration in the upper and lower sciatic sections. Changes were more pronounced in the nerve groups just outside the spinal cord. Slight passive congestion existed in the sciatic nerve, but no special lesion of the artery could be made out. This, in a general way, is the report of the findings from a research standpoint.

During the experimental stage at Kirksville the innominate lesions showed these points: no paralysis, peristaltic action increased, moderate glycosuria varying from one-tenth per cent to seventy-five hundredths per cent lasted from one to five or six days in some cases. The urinary findings showed increase in albumen a few days after the lesion and an increase in chlorides in one case. With no particular change in the specific gravity nor urea, qualitative and quantitative analyses were made in all of the cases before and after the lesions produced. A post-mortem examination found that the sublaxations were sufficient to justify the name lesion and produce the pressure and changes which would correspond with an innominate lesion in a typical case.

The sacro-iliac articulation is a true synchondrosis. Hulett's reference of a few years back, "Bear in mind the fact that the sacro-iliac articulation is an arthrodial or gliding joint, and in many younger individuals is supplied with the typical structures including the synovial membrane and fluid. This suggests a fair degree of movement," etc., coincides with that of Goldthwaite in his "Diseases of the Bones and Joints," in which he states: "This of course impairs the normal function of the joint, and because of the character of the articulations in the pelvic girdle, it is evident that if one joint is injured each of the other joints must be somewhat strained, so that the disability resulting from even a slight luxation of one of the sacro-iliac joints may become very great." \* \* \* "In any disease of the pelvic organs in which

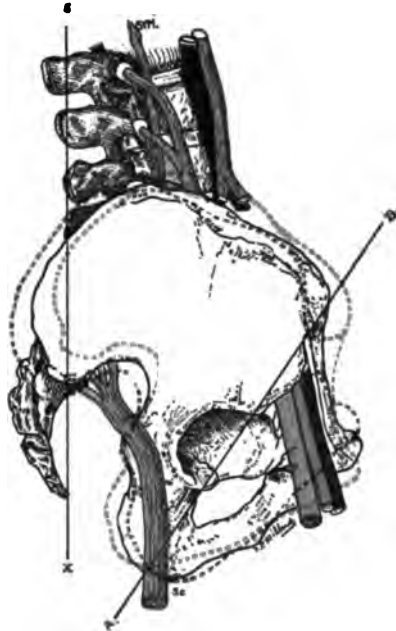

**PLATE XXXVI.**—Side view of the innominate in its normal position in relation to the sacrum. The dotted lines indicate the directions in which this bone is most likely to be misplaced. The line A. B. is used for diagnostic purposes, passing as it does through the center of the acetabulum and the superior anterior spine and the tuberosity of the ischium.

(Through an error in interpreting instructions our engravers made this cut smaller than the following two.—Ed.)



there is large circulatory disturbance the joints become relaxed, as a part of the same physiological reflex noted in pregnancy and menstruation. While this is probably true, the converse is also certainly true; namely, that if the pelvic joints become relaxed as the result of accident or disease, the lack of stability of the pelvic girdle, with the resultant weakening of the support of the pelvic organs, leads to congestive disturbances in these organs, this in turn probably acting upon the joints, so that until the proper treatment can be instituted there exists a vicious circle of cause and effect." "The bone surfaces are smooth and slightly irregular, so that the stability of the joint depends almost entirely upon the ligaments and muscles. This being the case, anything that leads to the loss in the muscular or ligamentous tone renders the joints more prone to strain, and as their stability depends upon soft structures, disturbances in the normal approximations in the bones must be more common and result from less violence than in the other joints."

Some years ago Dr. Hazzard made some interesting clinical experiments, illustrating the same, with, I believe, the first diagrams showing a slipped innominate. He stated "that bony and ligamentous lesions of the pelvis, so significant from the osteopathic standpoint, are causes of disease in the pelvic viscera, in the limbs or in the body above," and that "the general symptoms of said troubles are pelvic diseases, female disorders, backaches, neck lesions, sciatica, lameness or paralysis of the lower limbs, etc." Research experiments carried out by Deason and McConnell have demonstrated the accuracy of his prophetic statements.

Goldthwaite makes the statement that in injuries not only are the joint structures injured or strained, but the large nerve trunks which cross this articulation in front are frequently irritated. "Anatomically the sacral plexus of nerves with some of the branches from the lumbar plexus cross just in front of the synchondrosis. This being the case, it is not difficult to understand the fact that irritation of these nerves is possible." Deason's experiment does not confirm this statement, although further experiments

may prove in some long standing case that deposits exist which interfere with the tonicity of these nerve cords in their relation to the sacro-iliac joint near the promontory of the sacrum.

Deason says: "What, for example, is the explanation of the extreme nervousness, menstrual disorders, intestinal disturbances, etc., which so often follow so soon after a slight lesion of the innominate has occurred, and which has neither increased nor involved other pelvic joints? That such conditions may exist we have shown by experiment. We believe the explanation in such cases is this: That reflex effects, involving certain viscera, as has been mentioned could result from the stimulation of some afferent or mixed nerve by pressure or otherwise, we can say that the theory, at least, seems tenable when we recall that such reflexes have many times been demonstrated. Many of these reflexes are furthermore specific in action, such, for example, as the contraction of the uterus from mechanical stimulation to the perineum or direct stimulation of certain sacro-spinal nerves." Schafer states that "In animals such contractions are strongly excited by faradization of the central end of the first sacral nerve. As the excitation in these instances is not applied to the uterine tissue or to afferent nerve channels, the resultant uterine reactions must be induced reflexly."

The research work so far has at least shown a perverted physiological condition affecting the splanchnic region as well as the renal. This ends our comment on the experimental work, which we hope will soon be completed by those who are working to that end.

The innominate bones form the greater part of the boundaries of the pelvic cavity and hence have the greatest ligamentous and muscular attachments, containing at the same time the thigh-bone sockets. From the upper border of the innominates arise the largest muscles in the back, extending as far as the skull in some instances. From these same bones the ensheathing muscles of the thigh arise, and in relation to these innominates pass some of the largest blood vessels and nerve trunks in the human body. Within the basin whose walls are formed by the innominates, in particular, lie some of the most delicate structures and tissues.

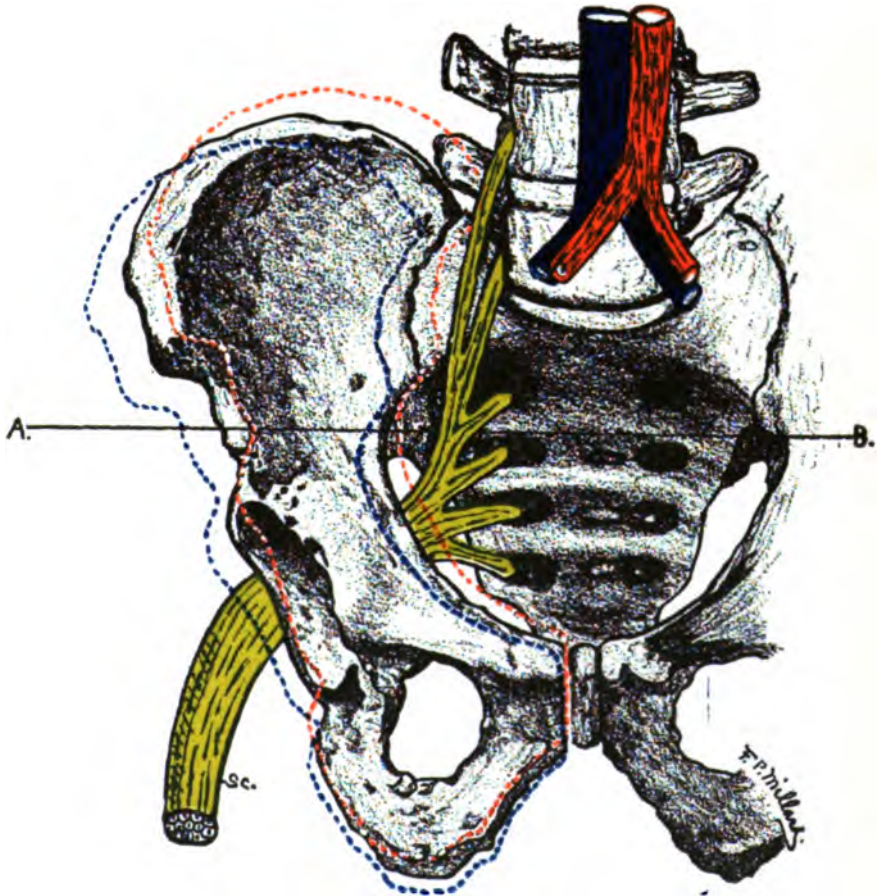
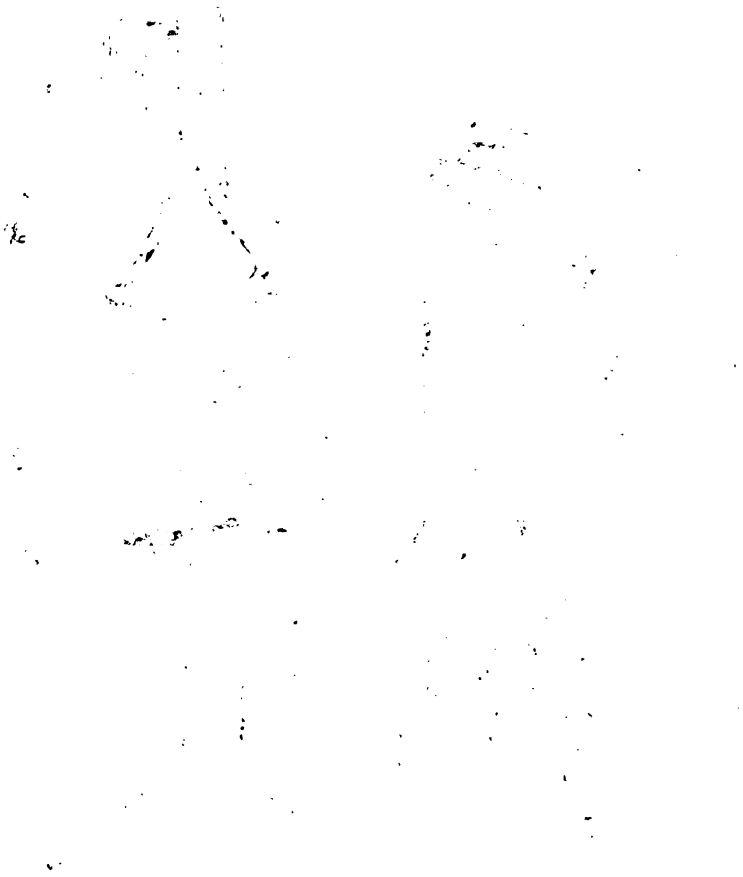

PLATE XXXVII.—Shows the anterior view of the pelvis with the innominate in normal position. A. B. is the transverse axis upon which the innominate turns when subluxated. The dotted lines indicate the different positions which the innominate would be most likely to assume.



The weight of the body and its burdens falls upon the sacrum, which is wedged between the innominate bones in an oblique position, necessitating great ligamentous and muscular counter-acting forces. It is the close proximity of the nerves and vascular tissue of the sacro-iliac joints, bound down as they are by fascia and connective tissue, that has concerned us in cases of rheumatism in which the possibility of a lesion at the sacro-iliac joint may thicken the tissues and possibly leave a deep-seated deposit, referred to already in this article. It is impossible to change the position of the sacrum and not disturb the integrity of the pelvic basin itself. If the sacrum is rotated in any direction the innominates are changed in their relation to this bone, and when the innominates are twisted the ligaments and muscles attached to them are likewise altered. Again, when the ligaments and muscles are put upon a tension or unduly relaxed the vascular and nervous tissues are deranged, and when innervation and vascularity are abnormal the organs and tissues supplied likewise suffer, and reflexly adjacent organs are usually involved. Although a sacral rotation may seem simple, yet a joint disturbance may be the outcome through a reflex chain of reasoning just referred to.

From a mechanical standpoint the pelvis is one of the most intricate pieces of mechanism in the human anatomy. Imagine the muscular and ligamentous tension placed upon the pelvic tissues when burdens are being carried. Irregularities of the pelvis do not constitute lesions unless associated with tenderness and disturbance of function of the articulations or associated viscera. Lesions in pelvic disorders may include not only those of the pelvic construction, but subluxations or partial displacements of the last rib, and the lower dorsal, as well as the lumbar vertebræ. Reasoning from an anatomical standpoint, disturbed function may follow mal-alignment of the lower dorsal region, as such a lesion may irritate the deep origin of the sciatic and pudic nerves and possibly the lumbar and sacral nerves. We must remember that the pudic nerve arises from cord segments, on a level with the twelfth dorsal to the first lumbar vertebræ. Remember the cord terminates at the upper border of the second



lumbar vertebra. If the origin of the lumbar and sacral nerves is above the point of spinal-cord termination, a lesion in the lower dorsal must directly or indirectly affect the nerves just mentioned. These nerves have a controlling influence over the pelvic organs and tissues. The lower dorsal lesions affect the general nutrition of the cord, as well as the blood supply to the particular segment. It is quite improbable that a lesion would exert pressure sufficiently to affect the nerve trunks directly, as paralysis would naturally ensue, but subluxations could be of sufficient significance to affect the nutrition and vascular supply of the cord and its branches, disturb the venous drainage which is conveyed by way of the intercostal, lumbar, and pelvic veins. However slight the subluxation, vascular irregularities will follow until complete reduction of the lesion is made. If contracted muscles exist venous stasis is most likely present, and as the vessels in the deep muscles are closely connected with those of the vertebral, as well as the cord segments, it is easy to understand the importance of correcting and adjusting the slightest abnormalities.

If venous stasis exists in the spinal cord vessels for any period of time degeneration of the cells must take place, and if the lesion is of sufficient importance to disturb the posterior root ganglion, the impingement must be removed or pathological conditions will follow. Should the rami communicantes in any way become involved the connecting link between the spinal and sympathetic system becomes interfered with, and the reflex actions are lost.

The pudic nerve supplies so many pelvic organs and tissues and its origin is so high that there must be perfect nutrition and complete freedom from irritation and congestion to insure the passing of normal impulses. The position as well as the functionings of the pelvic organs depend greatly on the density of the pelvic-floor tissues. If lack of tone exists a disarrangement may take place in the way of misplacements, congested areas, adhesions, etc. This may be due to visceral ptosis, but more often it is the result of faulty innervation induced by improper nourishment of the nerve trunks and tissues. Back of all this disturbance a slipped innominate may have been the primary cause.

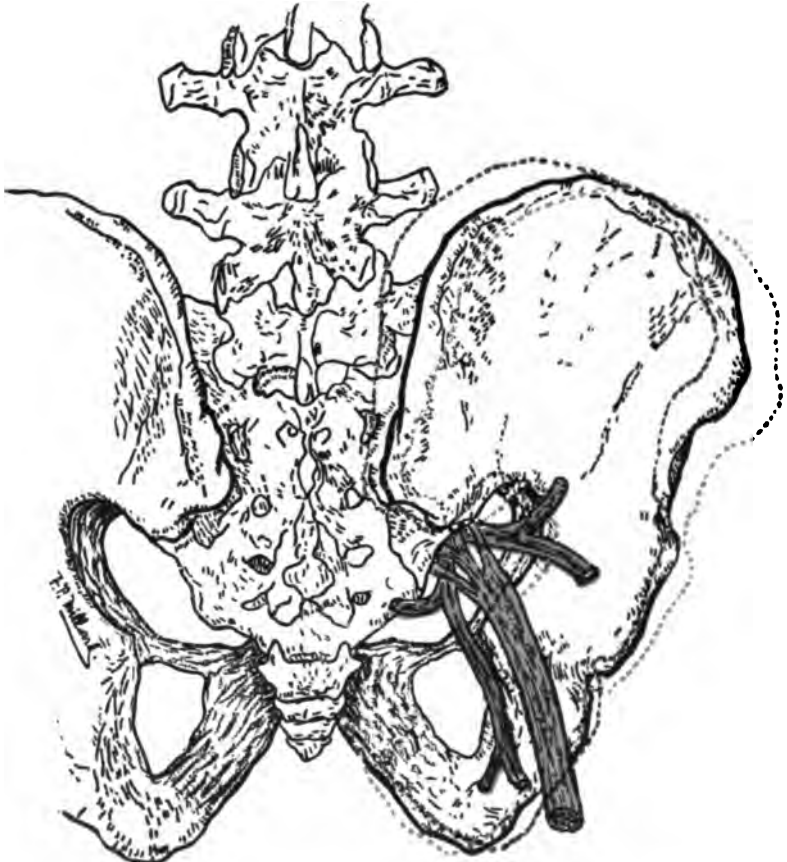

**PLATE XXXVIII.**—Posterior view of the pelvis in its normal relationship to the sacrum. The dotted lines show the innominate twisted forward and backward on its transverse axis in relation to the sacrum.



Whenever the lower thoracic region is under consideration we must not forget the rib attached thereto. The eleventh and twelfth ribs are frequently found in lesion, possibly through tight lacing or faulty position, but usually the result of scoliotic conditions. These costal lesions cause disturbances in the rami, producing trouble in renal and ovarian plexuses. As the ganglia of the sympathetic cord lie in such close relationship to the heads of the ribs, and as these two ribs are floating and have no anterior support other than muscular, displacement is easy and disturbance of the sympathetic ganglia is common. The return vascular flow from the pelvic organs may be checked somewhat by a subluxation of the lower ribs which constrict to a certain extent the vascular openings in the diaphragm. This may be of sufficient import to produce congestion in part or all of the pelvic organs, but it will depend entirely on the manner and extent to which the ribs are subluxated.

Lumbar lesions are so common in cases of pelvic troubles that we naturally look for vasomotor and trophic changes through disturbance of the sympathetics. The ganglia lie in front of the bodies of the vertebræ in this region, and are connected with the lumbar nerves and plexuses, as well as the lumbo-sacral cord through the rami communicantes. These ganglia supply plexuses to the various arterial branches of the abdominal aorta, such as the inferior mesenteric, ovarian, branches to the uterus, tubes, etc. The lower portion of the colon, including the sigmoid, receives nerve filaments from this same source, making possible a variety of complications to the bowels as well as the tubes and ovaries. Whenever we find two or more organs supplied by nerves from practically the same source we may look for complications of troubles.

The sympathetic ganglionic chain sends branches to the hypogastric plexus, and disturbance to this plexus may also be caused by lumbar lesions, as it is located near the promontory of the sacrum adjacent to the fifth lumbar. Taken as a whole, the lumbar region is of great importance, and the lumbar enlargement of the cord contains centers for most of the pelvic organs. The pelvis normally is bound together with firm, ligamentous

bands, draped internally with fascia and muscles, which folds are perfect according to nature's intention. Suspended within this basin are the pelvic organs with ligamentous tension equal on all sides, and muscular supports as well. Misalignments, however slight, produce tension on certain of these on the one hand, and vascular inadequacy on the other. Resultant complications are inevitable. No mechanism will work in perfect harmony if friction exists, or if distortion be present. The toxic condition of the bowels, due to faulty innervation or vascular irregularities through lesions or structural defects, invariably causes disorder in proportion to the severity of the lesion. In order that the normal function may exist and continue, organs and nerves must not be impinged upon and vascular freedom must be present. The vasomotors must be in perfect working order as well as the tissues in which the blood vessels are imbedded.

The vasomotor centers controlling the circulation of the uterus are located in the lumbar region. A rigid spine, a curvature, or a specific lesion will affect these centers. As before mentioned, the hypogastric plexus is situated at an extremely important point, helping as it does to form the pelvic plexuses, which are made up principally from the upper sacral ganglia, the second, third and fourth sacral nerves. These plexuses serve as switching stations for almost as many impulses as does the solar plexus, and control chiefly the various pelvic functions such as secretions, absorption, ovulation, uterine peristalsis, menstruation, gestation, etc. This plexus also furnishes vasomotor fibers to the pelvic organs.

Regarding visceral ptosis, not only pelvic misplacements are the result, but the blood supply of that region is disturbed and venous and lymphatic stasis ensues. A foundation is thus laid and material furnished for tumors and various growths. The arteries are usually capable of expansion under ordinary circumstances. Any great interference or resistance may produce aneurism. The venous circulation, on the other hand, has less propelling power, and the veins are more readily engorged. In such a case the arterial flow is undisturbed and the new growths are the result of tumefaction from the disturbed lymph and blood channels.

## INDEX.

- Absorption in the intestines, 164  
Accommodation, mechanism of, 369  
Accessory foods, 199  
Adrenal bodies, 219  
Air pressure in thorax, 115-118  
Alcohol, 200  
Alimentary canal, from an osteo-  
pathic standpoint, 177  
spinchter valves of, 175  
Altitude, effects of on respiration, 131  
Amboceptors, 26  
Anacrotic limb, 86  
Antibodies, 26  
Antithrombin, 33  
Aphasia, 327  
Artificial respiration, methods of pro-  
ducing, 113, 114  
Atropin, 59  
Auditory sensations, 354  
course of, 356  
Autonomics, cranial, 76  
Autonomic nerves to heart, 55-63  
to blood vessels, 64-77
- Bacteria and phagocytosis, 29  
Bacteriolysins, 29  
Bell-Magendie law, 266  
Bile, constituents of, 158  
secretion of, 159  
Bladder, structure and function of, 185  
nerve supply to, 185  
Blood, 19  
chemical properties of, 31  
clot, 33  
coagulation, 32  
constituents of, 21  
corpuscles of, 21  
corpuscles, white, 27  
distribution, 38  
effects of bony lesions on forma-  
tion of, 453  
letting, 37  
of neurasthenics, 456  
plasma, 21  
plates, 30  
properties of, 20  
proteins, 31  
serum, 21  
Blood cells, Burns' researches on,  
447-461  
Blood pressure, 80  
conditions causing variation in,  
92  
effects of respiration on, 120  
methods of study of, 80  
normal, 84  
systolic and diastolic variation  
of, 82  
variations in, 84
- Blood flow, velocity of, 78  
variation in, 79  
Blood pressure and velocity, physical  
laws of, 94  
Blood pressure variations, experi-  
mental, 511  
Blood velocity, variations in, 92  
Body energy, 201, 204  
measurement of, 202  
Body fluids, 19  
Body temperature, 204  
Body temperature and environ-  
ment, 207  
normal, 209  
Bony lesions, 464  
Bony lesions and blood formation, 453  
Brain, blood supply to, 70  
efferent fibers in, 332  
physiology of, 320-333  
a complex reflex center, 220
- Carbon dioxide changes in respira-  
tion, 122-127  
Carbohydrate metabolism, 195  
Carbohydrate metabolism and bony  
lesions, 517  
Carbohydrates, functions of, 197  
Cardio accelerators, 60  
center of, 61  
reflex and tonic activity of, 62  
Cardiac cycle, 49  
Cardiac impulse, 89  
Cardio-inhibition, cause of, 58  
Cardio-inhibitors, reflex action of, 58  
Cardio-inhibitory center, 57  
Centers, spinal, Burns' researches  
on, 471-492  
Cerebellum, functions of, 333  
Cerebrospinal fluid, 42  
Cerebrum, Broca's area in, 327  
extirpation of, 323, 324  
motor areas of, 330, 331  
sensory areas of, 325  
Wernecke's area in, 327  
Chemical changes in active muscle,  
250  
Chemistry of respiratory changes,  
122-124  
Cheyne-Stokes respiration, 128  
Choroid coat of eye, 363  
Chromophile bodies, 220  
Ciliary body, 364  
Ciliated epithelium, 229  
Circulation, discovery of, 37  
effects of respiratory movements  
on, 119  
organs of, 44  
physical factors involved in, 91  
purpose of, 19  
time of, 78

- Coagulation of blood, 32
  - causes of, 33
  - methods of increasing, 35
  - methods of preventing, 35
- Cochlea, 355
- Cocoa and chocolate, 199
- Coffee and tea, 199
- Colon, movements of, 171
  - nerve supply of, 172
- Color index, 458
- Columns of the cord, 310-314
- Complement, 26
- Conclusion, McConnell's, 400
- Conclusion to Series No. 2, 513
- Condiments, flavors, etc., 200
- Conduction paths of cord, 310-314
- Consciousness, physiology of, 493-502
- Constituents of urine, 184
- Contractile tissue, 229
- Contraction wave, 241
  - voluntary contractions, nature of, 242
- Control work, 399
- Corpuscles, 21
  - variation in number of, 21
- Cranial nerves, 315-319
  - abducent, 316
  - accessory, 318
  - auditory, 317
  - facial, 317
  - glossopharyngeal, 317
  - hypoglossal, 318
  - oculo-motor, 315
  - olfactory, 315
  - optic, 315
  - pneumogastric, 318
  - trigeminal, 316
  - trochlear, 316
- Defibrinated blood, 32
- Deglutition, 142, 143
- Diaphragm, movements of, 103
  - innervation of, 103
- Dicrotic wave, causes of, 87
- Digestion in stomach, 150
- Drugs, effects of on stomach secretion, 150
  - effects of on heart, 59
- Ductless glands, physiology of, 217
- Ear, physiology of, 353
  - external, 353
  - middle, 353
- Efferent fibers of brain, 332
- Enzymes, 139
  - classification of, 141
  - general properties of, 139
  - kinds of, 141
- Equilibrium and health, 430
- Ergograph, use of, 243
- Eye, coats of, 362-364
  - physics of, 366
  - physiology of, 362
  - refractive media of, 367
- Erythroblasts, 22
- Erythrocytes, 21, 22, 23, 458
- Excretory organs, 181
- Experimental work, McConnell, 380
- Fats, digestion in intestines, 156
  - functions of, 198
  - metabolism of, 198
  - source of, 198
- Fibrin, 32
- Fibrinogen, 32-33
- Foods, 137
  - composition of, 137
- Fundamentals of the lesion, 438
- Gastric secretion and digestion, 148
  - methods of study of, 148
- General principles, 412
- Glycosuria, see Series No. 4, 517
- Hearing, theory of, 355
- Heat production in body 204
  - regulation of loss of, 205
  - regulating mechanism, nerve supply of, 206
- Heart, 45
  - beat, causes of, 50
  - blood pressure in, 48
  - muscle, tone of, 54
  - nerve supply to, 55
  - sounds, 87, 88
  - valves, 46
- Hemoglobin, 457
- Hemoglobin, 22, 23
  - compounds, 24
  - crystals, 25
  - determination of, 24
- Hematopoietic organs, 22
- Hemolysis, 25
- Hemolysins, 26
- Hemolytic agents, 25
- Hormones of stomach, 149
- Hunger, sensation of, 352
- Hyperthyroidism, 225
- Idiomuscular contractions, 241
- Impure air, effects of breathing, 125
- Induction coil, 89
- Inorganic salts, 199
- Internal secretions, 213-225
  - methods of study of, 215
- Intestines, absorption in, 164-167
- Intestines, movements in, 170
- Intrapulmonic and intrathoracic pressure, 115
- Intravascular clotting, 35
- Iris, 364
  - nerve control of, 364
- Kidneys, excretions of, 184
  - formation of urine in, 181
  - internal secretions of, 225
  - nerve supply to, 181
- Knee jerk, 308

- Lactic acid in stomach, 151
- Lesion, osteopathic, 373
  - dissection of, 382
  - microscopic findings in, 384
- Leucocytes, 459
  - Amphophiles, 460
  - Basophiles, 460
  - Eosinophiles, 460
  - Lymphocytes, 459
  - Neutrophiles, 459
- Leucocytes, 27
  - classification of, 27
  - functions of, 29
  - normal number of, 27
  - phagocytic action of, 29
  - variation in, 27
- Liver and pancreas, relations of, 520
- Liver, bile formation in, 158
  - functions of, 160
- Lipase, gastric, 151
- Lungs, nerve supply to, 104
- Lymph flow, 41
  - functions of, 41
  - osteopathic considerations concerning, 43
- Lymph, 20, 39
  - general properties of, 39
  - origin and formation of, 39
- Lymph vessels, 40
- Lymphagogues, 40
- Lymphocytes, 27
- Mast cells, 29
- Mastication, 142
- Metabolism, 193-200
  - of carbohydrates, 195
  - of fats, 198
  - of proteins, 193
- Microscopic examination of the osteopathic lesion, 384
- Micturition, 184
- Movements of stomach and intestines, 168
- Muscle, artificial stimulation, 234
  - blood and nerve supply to, 231
  - chemical properties of, 248
  - conditions affecting, 237
  - contraction of, 236
  - effects of curare on, 233
  - elasticity and extensibility of, 232
  - energy and work, 249-250
  - fatigue of, 253
  - general properties, 232
  - heart, 231
  - irritability, 233
  - latent period of, 237
  - physiology of, 230-255
  - smooth, 231 striated, 230
  - time, 236
  - tissue, normal functions of, 243
  - tone, relation to spinal cord, 307
- Muscle contraction, tetanic and compound, 239
- Muscle contracture, 238
  - causes of, 238
- Muscle tonus, 245
  - physiological significance of, 246
- Muscles of respiration, 105, 106
- Muscular contraction, causes of, 255
- Muscular rigor, 249
- Muscular work, 251
  - efficiency, 252
- Muscarin, action of on heart, 59
- Neuron doctrine, 272
- Neurones, classification of, 277-280
  - cortico-spinal, 334
  - spino-muscular, 336
  - upper motor, 334
- Nerve cell, relation of to its processes, 274
- Nerve conduction, 261
  - conductivity, variation in, 262
  - impulse, 261
- Nerve control of the iris, 364
- Nerve degeneration, 275
  - regeneration, 276
- Nerve energy, source of, 280, 305
- Nerve fibers, afferent and efferent, 265-266
  - classification of, 267
  - direction of conduction in, 265
  - functional differences in, 265
- Nerve force, measurement of, 349
- Nerves, somatic afferent, 416
  - somatic motor, 417
  - visceral afferent, 416
  - visceral efferent, 417
- Nerve supply to the alimentary canal, 173
  - to colon, 172
  - to blood vessels, 64
  - to bone marrow, 453
  - to diaphragm, 514-516
  - to kidneys, 181
  - to the heart, 55
  - to lungs, 104
  - to muscles of respiration, 107
  - to the pancreas, 154
  - to salivary glands, 145
  - to the stomach, 149
  - to taste buds, 360
- Nerve reflexes, 283
- Nerve tissue, changes resulting from lesion in, 426
  - fiber, structure and function of, 259
  - medullated and non-medullated, 260
- Neuro-muscular mechanism, 242
- Nerve trophism, 302
- Nervous system, sympathetic,
  - effects of lesion on, 419
- Normalization of animals for experimental work, 528
- Nutrition and spinal lesions, 549-556



- Olfactory sensations, 358  
 conduction of, 358  
 properties of, 358
- Opsonins, 29  
 Whiting's researches on, 503-505
- Osteopathic centers, 436
- Osteopathic considerations of physiology of the liver, 162  
 of kidneys, 186
- Osteopathic lesions, 464  
 effects of on carbohydrate metabolism, 517  
 effects of experimental, 509  
 effects on functions of the colon, 172  
 effects of on gastric digestion, 153  
 effects of on monkeys, 549  
 effects of on nutrition, see series No. 12  
 effects of on viscera, 396  
 experimental evidence of, 509  
 fundamentals of, 438  
 immediate effects of, 541  
 McConnell's researches, 373-444  
 nerve changes resulting from, 426  
 pathologic changes from, 431  
 practical considerations of, 433  
 production of in animals, 529  
 urinary changes from. See Series Nos. 4 and 12
- Osteopathic stimulation and inhibition, 536
- Osteopathic stimulation, See Series Nos. 16 and 17.
- Osteopathic theory, 406
- Osteopathic therapy, experimental evidence, 549
- Ovaries, 221, 222
- Oxygen, changes in respiration, 122-124
- Oxyhemoglobin, 25
- Pain, sense of, 346
- Pancreas and liver, relations of, 520
- Pancreas, internal secretions of, 217  
 experimental work on, 518  
 methods of study of, 154  
 secretory nerves of, 154
- Pancreatic juice, properties of, 157
- Paralysis, from lesions of gray and white matter, 338  
 due to trauma of cord, 339
- Parathyroid glands, 225
- Pericardium, 48
- Phagocytes, 29
- Phrenic nerve, 514-516
- Physics of the eye, 366
- Physical factors involved in circulation, 91
- P. M. I., the, 89
- Pineal body, 223
- Pituitary body, 222
- Plasma, 21, 25
- Plethysmograph, 65
- Pleura, 100
- Post-mortem examination after lesion, 530
- Polymorphonuclear leucocytes, 28
- Practical application of principles, 442
- Practical considerations of the lesion, 433
- Protein digestion in intestines, 156
- Proteins, digestion of, 150
- Proteins of the blood, 31
- Protein metabolism, 193
- Protein spasers, 194
- Properties of urine, 184
- Prothrombin, 33
- Pupil, causes of constriction of, 365  
 dilation of, 366
- Pulse, 85-87
- Reflex action of cardio-inhibitory center, 58
- Reflex action, effects of drugs on, 301  
 effects of osteopathic lesions on, 301  
 relation of cord to, 300
- Refraction, abnormal, causes of, 368  
 normal and abnormal, 368
- Reflexes, inhibition of, 298  
 kinds of, 287-294  
 osteopathic significance of, 297  
 sympathetic, experimental work on, 534
- Reflex action, animals, 295  
 Burns' researches on, 462-470  
 paths, 295  
 specificity of, 286
- Reflex arc, 285
- Reflex mechanism, 283
- Rennin, action of, 151
- Respiration, 99  
 active and passive, 101  
 chemical changes in, 121  
 cutaneous, 189  
 diaphragmatic, 112  
 external and internal, 99  
 movements and rate of, 101  
 movements of, 111  
 muscles of, 105, 106
- Respiratory organs, 99
- Respiratory center, action of, 107  
 secondary, 108  
 regulation of, 109
- Respiratory changes, physics of, 121
- Respiratory movements, causes of, 102  
 abnormal, 128  
 effects of exercise on, 129  
 measurement of, 112
- Respiratory quotient, 132
- Retina, functions of, 363

Saccule, 357  
Saliva, general properties of, 146  
    functions of, 147  
    variation in secretion of, 146  
Salivary glands, 144  
    nerve supply of, 145  
Saliva and salivary digestion, 144  
Sclerotic coat of eye, 362  
Sebum, secretion of, 189  
Secretion theory of kidneys, 183  
Secretagogues of stomach, 149  
Secretion and digestion in the intestines, 154  
Secretion in intestines, 157  
Semicircular canals, 356  
Sensation of hunger, 352  
Sensations, cutaneous, 350  
    internal and external, 346  
    special classification of, 345  
Sensibilities, deep, 351  
Sensory disturbances from cord lesions, 340  
Sense of taste, 359  
    of smell, 358  
    of thirst, 351  
Series No. 2, 510  
Series No. 3, 514  
Series No. 4, 517  
Series No. 5, 534  
Series No. 7, 536  
Series No. 9, 539  
Series No. 12, 549  
Series No. 15, 558  
Series No. 16, 560  
Serum-globulin, 32  
    albumin, 32  
Skin, functions of, 187  
Smell, sense of, 358  
    end organs of, 358  
    mechanism of, 358  
    sensativeness of, 359  
Sphincter valves, 175  
    regulation of, 175  
Specific nerve energies, theory of, 347  
Specific nerve energies, mechanism of, 269  
Sphygmograph, 86  
Sphygmogram, 86  
Spinal areas, 512  
Spinal centers, Burns' researches on, 471-492  
Spinal cord, effects of complete division of, 340  
Spinal cord centers, 308  
    effects of extirpation of, 307  
Spinal cord pathways, 514  
Spinal shock, 339, 543-546  
Spinal stimulation, effects of, 465  
Spinal treatment, effects of intestines, 179  
Spinal strain, 546  
Spirometer, 113

Spleen, physiology of, 180  
Starch, digestion of, 150  
Stimulants, 199  
Stimulation and inhibition, osteopathic, 536  
Stimulation, visceral effects of, 466  
    spinal, effects of, 465  
Stomach, absorption in, 151  
    osteopathic considerations, 177  
    movements of, 168  
    methods of study of, 169  
    secretory nerves to, 149  
Stroma, 21  
Sweat, constituents of, 188  
    osteopathic considerations, 189  
Sweat glands, 187  
    constituents of, 188  
Sympathetic nerves. (See autonomics)  
Synapse, nature of, 272-274  
Taste sensations, fundamental, 360  
    properties of, 360  
Taste, sense of, 359  
Testes, 221  
Tetanus, muscular, 239  
    pathological, 240  
Thirst, sense of, 351  
Thoracic cavity, 101  
Thrombin, 33  
Thrombokinase, 33  
Thymus gland, 220  
Thyroid glands, 224  
Transitional leucocytes, 28  
Tracts of the cord, 310-314  
Treatment, specific, 436  
Utricle, 357  
Vagus nerve, 55  
    inhibitory action of, 56  
Vascular changes resulting from lesion, 423  
Vaso-constrictors to head and neck, 72  
    to abdominal viscera, 73  
    to genital organs, 75  
    to upper limbs, 72  
Vaso-constrictors, 68  
    structures supplied by, 70  
Vaso-dilators, 75  
    to cranial, 76  
    nature of action of, 77  
    spinal autonomics, 76  
Vasomotor centers, 66  
    reflexes, 67  
Vasomotor supply to pelvic viscera, 74  
Vasomotor fibers, 64  
    kinds of, 64  
Velocity of blood flow, 78  
Viscus, effects of osteopathic lesions on a, 396  
Volume index, 458

# Studies in the Osteopathic Sciences

BY

**LOUISA BURNS, M. S., D. O., D. Sc. O.,**

Professor of Physiology, The Pacific College of Osteopathy.

---

---

## **Volume I—Basic Principles.**

A discussion of those facts of biology and physiology upon which osteopathic practice is based; the experimental demonstration of the effects of bony lesions, illustrations, glossary, bibliography.

## **Volume II—The Nerve Centers.**

A description of the nerve centers and their constituent neurons; discussions of the manner in which the activities of the nerve centers may be disturbed, with especial reference to the osteopathic principles, accounts of original work; freely illustrated; tables of the nerve centers and tracts, glossary, bibliography.

## **Volume III—The Physiology of Consciousness.**

A description of the cerebral cortex and its relations; a discussion of consciousness and its varying states in terms of the physiological activities of the cortical neurons; comparison of the theories of psychology; illustrations, glossary, bibliography.

## **Volume IV—The Blood.**

A description of the blood, its development, physiology, morphology, and pathology; osteopathic methods applied to blood variations; colored plates; glossary, bibliography.

**Price \$4.00 per volume, postpaid.**

---

---

**Address DR. M. L. BURNS**

**The Pacific College of Osteopathy      LOS ANGELES, CAL.**



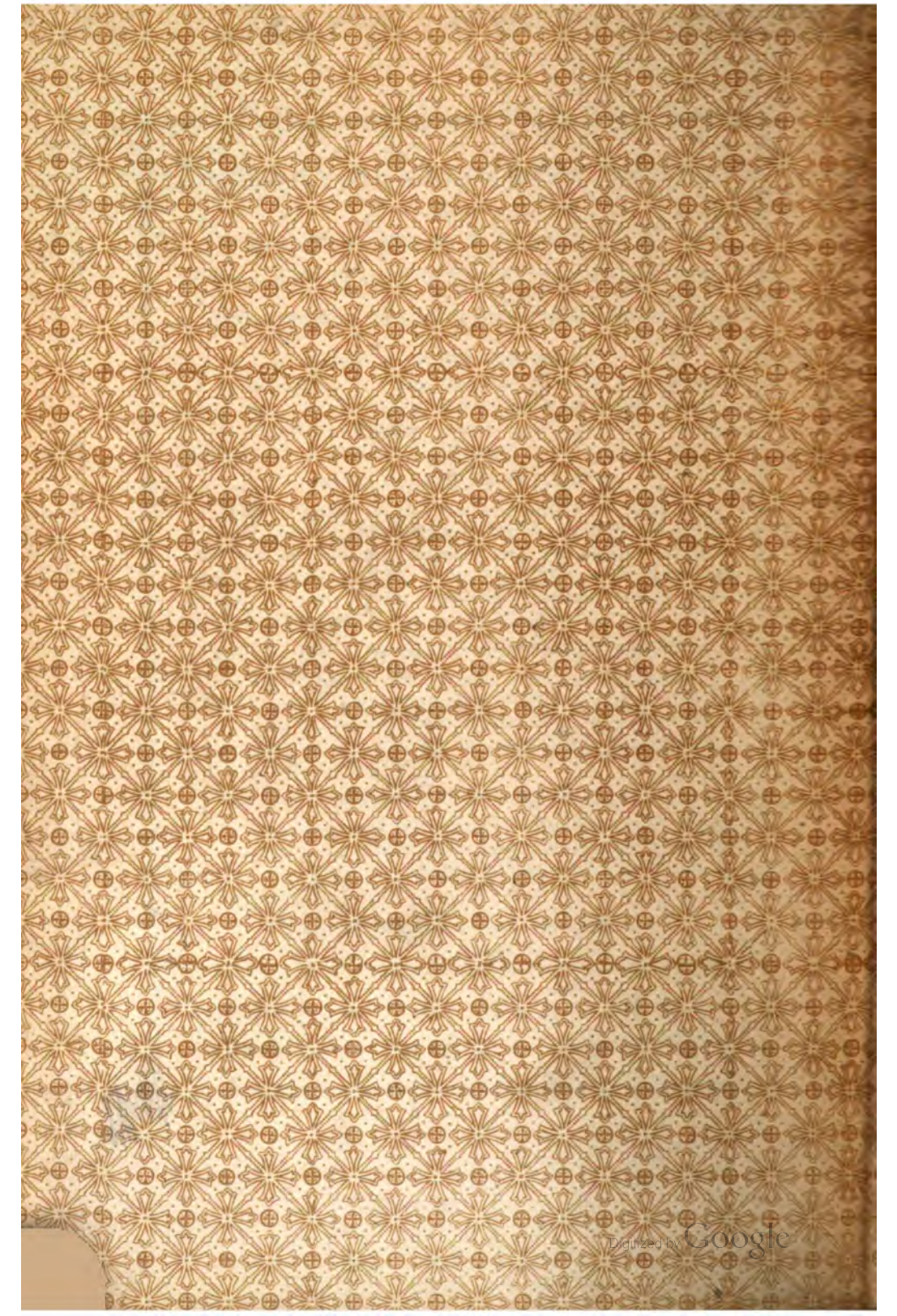

HC 2PBJ 0

Physiology  
Countway Library  
BDV9264  
3 2044 045 538 683

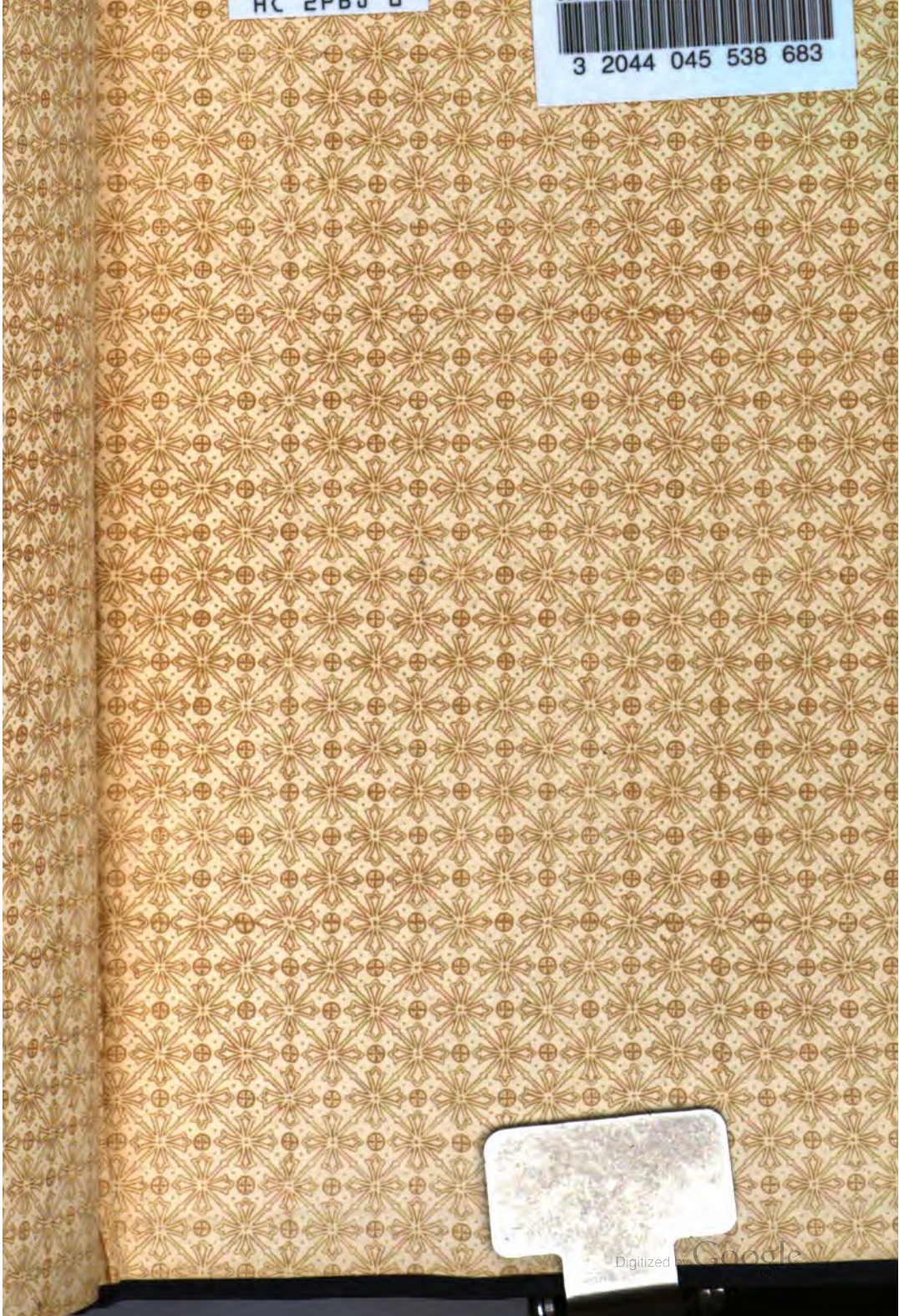

l. 3508  
Physiology: general and osteopa1913  
Countway Library BDV92



3 2044 045 538 684